SCHOLAR Study Guide

Higher Physics

Unit 2: Particles and Waves

Authored by:

Ian Holton (previously Marr College)

Reviewed by:

Grant McAllister (Bell Baxter High School)

Previously authored by:

Douglas Gavin

John McCabe

Andrew Tookey

Campbell White

Heriot-Watt University

Edinburgh EH14 4AS, United Kingdom.

First published 2014 by Heriot-Watt University.

This edition published in 2017 by Heriot-Watt University SCHOLAR.

Copyright © 2017 SCHOLAR Forum.

Members of the SCHOLAR Forum may reproduce this publication in whole or in part for educational purposes within their establishment providing that no profit accrues at any stage, Any other use of the materials is governed by the general copyright statement that follows.

All rights reserved. No part of this publication may be reproduced, stored in a retrieval system or transmitted in any form or by any means, without written permission from the publisher.

Heriot-Watt University accepts no responsibility or liability whatsoever with regard to the information contained in this study guide.

Distributed by the SCHOLAR Forum.

SCHOLAR Study Guide Higher Physics: Unit 2

Higher Physics Course Code: C757 76

ISBN 978-1-909633-27-8

Print Production and Fulfilment in UK by Print Trail www.printtrail.com

Acknowledgements

Thanks are due to the members of Heriot-Watt University's SCHOLAR team who planned and created these materials, and to the many colleagues who reviewed the content.

We would like to acknowledge the assistance of the education authorities, colleges, teachers and students who contributed to the SCHOLAR programme and who evaluated these materials.

Grateful acknowledgement is made for permission to use the following material in the SCHOLAR programme:

The Scottish Qualifications Authority for permission to use Past Papers assessments.

The Scottish Government for financial support.

The content of this Study Guide is aligned to the Scottish Qualifications Authority (SQA) curriculum.

All brand names, product names, logos and related devices are used for identification purposes only and are trademarks, registered trademarks or service marks of their respective holders.

Contents

1	The standard model	1
1.1	Orders of magnitude	2
1.2	The standard model	3
1.3	Quarks	9
1.4	Bosons	11
1.5	Antimatter and PET scanners	12
1.6	Beta decay	13
1.7	Summary	16
1.8	Extended information	18
1.9	Assessment	19
2	Forces on charged particles	21
2.1	Electric fields	23
2.2	Work done and potential difference	29
2.3	Magnetic effects of current	33
2.4	Summary	48
2.5	Extended information	48
2.6	Assessment	49
3	Nuclear reactions	51
3.1	Radioactivity	52
3.2	Decay processes	53
3.3	Nuclear energy	58
3.4	Extended information	67
3.5	Assessment	67
4	Wave particle duality	69
4.1	Photoelectric emission	70
4.2	Photoelectric calculations	77
4.3	Uses of the photoelectric effect	78
4.4	Summary	80
4.5	Extended information	81
4.6	Assessment	82
5	Diffraction and interference	83
5.1	Diffraction	84
5.2	Interference	85
5.3	Holograms	98
5.4	White light spectra	99
5.5	Summary	104
5.6	Extended information	105

5.7	Assessment	106
6	Refraction of light	109
6.1	Refractive index	110
6.2	Total internal reflection and critical angle	121
6.3	Applications of total internal reflection	125
6.4	Summary	128
6.5	Extended information	129
6.6	Assessment	130
7	Spectra	133
7.1	Irradiance	134
7.2	Spectra	140
7.3	Summary	149
7.4	Extended information	150
7.5	Assessment	150
8	End of unit test	153
8.1	Open ended and skill based questions	154
8.2	Course style questions	156
8.3	End of unit assessment	162
A	Units, prefixes and scientific notation	169
A.1	Symbols and units used in Unit 2: Particles and waves	170
A.2	Significant figures	171
A.3	Scientific notation	173
	Glossary	175
	Hints for activities	179
	Answers to questions and activities	186

Topic 1

The standard model

Contents

1.1 Orders of magnitude	2
1.2 The standard model	3
1.2.1 Fundamental particles	3
1.2.2 Fundamental particles: Quarks and leptons	4
1.2.3 Fundamental forces	5
1.3 Quarks	9
1.4 Bosons	11
1.5 Antimatter and PET scanners	12
1.6 Beta decay	13
1.7 Summary	16
1.8 Extended information	18
1.9 Assessment	19

Learning objective

By the end of this topic you should be able to:

- compare different orders of magnitude of length from the astronomical to the subatomic;
 - describe some of the evidence for the sub-nuclear particles and the existence of antimatter;
 - state that there are four fundamental types of force (strong, weak, gravitational and electromagnetic) and describe each force;
 - state that fermions, the matter particles, consist of quarks (6 types) and leptons (electron, muon and tau, together with their neutrinos);
 - state that hadrons are composite particles made of quarks;
 - state that baryons are made of three quarks and mesons are made of two quarks;
 - state that the force mediating particles are bosons (photons, W and Z Bosons, and gluons);
 - state that beta decay gave the first evidence for the neutrino.
-

In this topic we will examine the scale of the universe and the particles that make it up.

We will begin by looking at orders of magnitude from the size of the universe down to the size of the particles that make up the nucleus of an atom.

In the second part of this topic we will examine what is known as the 'standard model of fundamental particles and interactions'. This is an attempt by physicists to describe the particles and forces that make up the universe.

1.1 Orders of magnitude

Large distances

The furthest that it is possible to observe is determined by two factors; the speed of light and the age of the universe.

The furthest distance that can be observed can be calculated by multiplying the age of the universe (13.7 billion years) by the speed of light ($3 \times 10^8 \text{ m s}^{-1}$). This gives a result of the order of 10^{26} m .

This is not the size of the universe it is only the furthest distance that can be observed from our position.

Small distances

Attempts have been made to measure the diameter of subatomic particles. Some of these particles are difficult to detect and to measure (their nature will be discussed later in this topic) and distances quoted in results of experiments may be subject to revision at a later date.

The diameter of one of these subatomic particles, the neutrino, is estimated to approximately the order of 10^{-24} m .

A more familiar particle, the proton, has a diameter measured at 10^{-15} m .

To most people these numbers are meaningless. It is almost impossible to imagine what such large or small numbers represent. The tables below attempt to put these numbers into perspective.

In both table the orders of magnitude are grouped so that each line in the table is a thousand times bigger than line before it.

Large objects

Distance range (m)	Examples
10^0 to 10^2	humans , trees, buildings
10^3 to 10^5	a mile, Mount Everest, wavelength of longest a.m. waves
10^6 to 10^8	Great Wall of China, diameter of the Moon, the Earth, Jupiter
10^9 to 10^{11}	largest total recorded distance for a car, distance to the sun
10^{12} to 10^{14}	Distance to Jupiter, distance of Voyager spacecraft from Earth
10^{15} to 10^{17}	Edge of solar system, interstellar space, light year, distance to nearest star
10^{18} to 10^{20}	Alkaid - star in the plough constellation, nearest star with identical properties to our sun
10^{21} to 10^{23}	edge of the galaxy, distance to the nearest galaxies (e.g. Andromeda)
10^{24} to 10^{26}	distant quasars, 100 million light years from milky way, furthest observable distance

Small objects

Distance range(m)	Examples
10^{-15} to 10^{-13}	diameter of proton, nuclear diameter, X-ray wavelength
10^{-12} to 10^{-10}	diameter of hydrogen atom, covalent bond length
10^{-9} to 10^{-7}	transistor gate thickness, wavelength of visible light
10^{-6} to 10^{-4}	blood cells, width of human hair
10^{-3} to 10^{-1}	VHF radio waves, length of insects

1.2 The standard model

Having examined the relative size of some objects in the universe, we will now look at the fundamental particles that make up all objects and the forces that cause them to interact.

1.2.1 Fundamental particles

Fundamental particles could be described as those particles that form the basic constituents of all the matter in the universe. Fundamental particles cannot be broken down into any smaller/sub particles.

In the early days of particle physics research, the fundamental particles were considered to be the proton, the neutron and the electron. Now, with the help of high energy accelerators, more than two hundred particles have been identified. The identification of these particles initiated a search for a theoretical description that could account for them all. The large number of these particles suggested strongly that they do not represent the most fundamental level of the structure of matter. In the early 1960s, physicists found themselves in a position similar to Mendeleev when the periodic table was being developed. Mendeleev realised that there had to be a level of structure, below that of

the elements themselves, which explained the chemical properties of elements and the interrelations between elements. One of the aims of the research in the area of particle physics is to discover rules or principles governing the large number of particles and explain their existence. The research has provided insights into how things might have been in the very beginning when the universe was just a few microseconds old.

Over the last 50 years many physicists have worked to develop a structure and order to particle physics. We now have what is called the **Standard Model of Fundamental Particles** which is an attempt to classify all of the known particles. The table below shows the fundamental particles.

Fundamental particles		
Fermions The matter particles		Bosons The force mediating particles
Quarks	Leptons	Photons
		W and Z bosons
		Gluons
		Higgs
		Gravitons
		Mesons

These are the three types of fundamental particles; quarks, leptons and bosons. They are called fundamental particles because they cannot be broken down into anything smaller.

1.2.2 Fundamental particles: Quarks and leptons

The fermion group of fundamental particles give rise to matter.

The fermion group consists of two groups of fundamental particles; quarks and leptons.

Fermions (two fundamental particles)		
Quarks		Leptons
Quarks combine to form Hadrons (Greek for <i>heavy</i>)		(Greek for <i>light</i>)
Baryons (made from combination of 3 quarks)	Mesons (made from combination of 2 quarks) (Greek for middleweight), these are also force mediating particles	
Examples • neutron • proton • antiproton	Examples • pion • kaon • upsilon	Examples • electron • neutrino • muon • tau

Quarks combine to form the hadron group. Remember **hadrons** are **heavyweight** and because hadrons can be broken down into quarks, they are not fundamental particles.

When 3 quarks combine, baryons are produced. You will recognise some of these particles; neutrons and protons.

Half-life of hadrons

Most of the hadrons decay spontaneously into other particles. They tend to have lifetimes of around 10^{-23} s, a very short time. Free neutrons have a half-life of about 15 minutes. Free protons are often said to be stable as their predicted half life is an extremely long period of time (10^{32} years).

Protons and neutrons are relatively stable when bound in a nucleus. However in certain nuclides they can decay to produce positive and negative beta particles.

When 2 quarks combine, mesons are produced. The **mesons** are **middleweight**, lighter than baryons but heavier than leptons. Mesons are members of the hadron group because they are made of quarks, but they are also bosons because they are involved with nuclear forces. There are very many different types of mesons and a few are listed in the table above.

Leptons are not made of quarks but they do cause matter. The leptons are **lightweight** and because leptons cannot be broken down into any small particles they are fundamental particles. The most common example of a lepton is an electron but others are also listed above.

As a result of investigations carried out in particle accelerators it has been found that antimatter exists. This means that for every particle listed above there is an antiparticle which will have the same mass but opposite charge. For example there is the proton which has charge +1 and its antiparticle, the antiproton, of charge -1. Both of these have the same mass. See 1.5 for more information on antimatter.

1.2.3 Fundamental forces

The interactions that occur between leptons, baryons and mesons can be described in terms of four forces. These forces are the strong force, the electromagnetic force, the weak force and the gravitational force. The strong force is associated with the interaction between hadrons. The weak force is associated with beta decay. The other two forces are the familiar ones we encounter in the everyday world. The table below compares these four forces, their interactions, their relative magnitudes and the range over which they act.

Fundamental forces on nature

Force	Acts on	Relative magnitude	Range
Strong	Hadrons only, in the nucleus	1	Around 10^{-15} m
Electromagnetic	Particles with charge or magnetic properties	10^{-2}	Infinite
Weak	Leptons mainly, often related to radioactive decay, so therefore in the nucleus	10^{-6}	Around 10^{-18} m
Gravitational	All forms of matter	10^{-38}	Infinite

One of the biggest challenges in physics is to explain fully the four fundamental forces. For example, there is no simple answer as to why the weak force affects some particles and not others. Theoretical physicists are currently testing the idea that the four forces are different manifestations of the same force. That is to say there is only one fundamental force and we perceive it to be acting in four different ways. The search therefore is for a Grand Unified Theory that will unite the four forces. The idea is analogous to the unification of the magnetic force and the electric force, where we imagine that these forces are different version of an electromagnetic force. Theoretical physicists suggest that the electromagnetic force and the weak force can be combined as an *electroweak force* when the interaction takes place over very short distances.

The third type of elementary particle, the boson, is used to explain the action of these fundamental forces.

Bosons (force mediating particles)	Associated with
Photons	Electromagnetic force
W and Z bosons	Weak nuclear force
Gluons	Strong nuclear force
Higgs	Help to explain the mass of particles
Gravitons	Not yet detected but thought to carry gravitational force through the universe
Mesons (yes, these are also classified as hadrons since they are a combination of 2 quarks)	Some of these are involved with nuclear force

The force acting on one object by another is due to the exchange of these force mediating particles.

For example:

Why does the nucleus not fly apart?

If all the protons within it are positively charged, then electrostatic repulsion should make them fly apart. There must be another force holding them together that, over the short range within a nucleus, balances the electrostatic repulsion. This force is called the strong nuclear force. As its name suggests, it is the strongest of the four fundamental forces but it is also extremely short range in action. It is also only experienced by quarks and therefore by the baryons and mesons that are formed by the combination of quarks.

It is the exchange of gluons between the hadrons in the nucleus which mediate (cause the action of) the strong force which holds the nucleus together.

The exact mechanism by which these bosons mediate the force is difficult to understand. For Higher CfE Physics all you need to know is that these bosons exist and are used in the explanation of the four fundamental forces. Be clear that boson is not the force, it only enables the force to act.

All of the forces and the reactions associated with them obey the conservation laws for energy, momentum, angular momentum and charge. The reactions of particles under the action of these forces also obey other conservation laws. One of these is called conservation of baryon number and another for hadrons is conservation of strangeness.

Example of conservation

The following table shows various fermions along with their baryon number and charge.

fermion	proton	antiproton	neutron	positive muon	negative muon
symbol	p	\bar{p}	n	μ^+	μ^-
Baryon number	1	-1	1	0	0
Charge	+1	-1	0	+1	-1

Using information from this table, state which of the following decays are possible.

Q1: Decay 1

Consider baryon number

$$\begin{array}{r}
 p + n \rightarrow p + \mu^+ + \mu^- \\
 1 + 1 \neq 1 + 0 + 0
 \end{array}$$

Decay 2

Consider baryon number, consider charge

$$\begin{array}{r}
 p + n = p + n + p + \bar{p} \\
 1 + 1 = 1 + 1 + 1 + -1 \\
 1 + 0 = 1 + 0 + 1 + -1
 \end{array}$$

The Standard Model: Questions

Go online



Q2: Which of the following statements about the Standard Model of fundamental particles is/are correct?

- i. The matter giving particles are called quarks and leptons.
- ii. The force mediating particles are called bosons.
- iii. Fermions are fundamental particles.

- a) (ii) only
- b) (i) and (ii) only
- c) (i) and (iii) only
- d) (ii) and (iii) only
- e) (i), (ii) and (iii)

.....

Q3: Which of the following statements about the Standard Model of fundamental particles is/are correct?

- i. There are two groups of matter particles, called quarks and leptons.
- ii. There are two different types of hadrons, called baryons and mesons.
- iii. The electron is a member of the lepton group.

- a) (ii) only
 - b) (i) and (ii) only
 - c) (i) and (iii) only
 - d) (ii) and (iii) only
 - e) (i), (ii) and (iii)
-

Q4: Which of the following statements about protons and neutrons is/are correct?

- i. Protons and neutrons are two of many types of hadron.
- ii. Protons and neutrons are baryons with baryon number 1.
- iii. Protons and neutrons within a nucleus are unstable.

- a) (i) only
 - b) (i) and (ii) only
 - c) (ii) and (iii) only
 - d) (i) and (iii) only
 - e) (i), (ii) and (iii)
-

Q5: Which of the following statements about the stability of the particles in the Standard Model of fundamental particles is/are correct?

- i. All hadrons are thought to be stable and do not decay.
- ii. Free neutrons are unstable, with a half-life of approximately fifteen minutes, and decay to produce a proton and a beta particle.
- iii. Free protons are often classified as being stable.

- a) (iii) only
 - b) (i) and (ii) only
 - c) (i) and (iii) only
 - d) (ii) and (iii) only
 - e) (i), (ii) and (iii)
-

Q6: Which of the following statements about conservation and interactions involving particles in the Standard Model of fundamental particles is/are correct?

- i. The electrical charge of a hadron is conserved during a nuclear reaction.
 - ii. Baryon number is conserved during an interaction.
 - iii. Strangeness number is conserved in interactions involving hadrons.
- a) (i) only
 - b) (i) and (ii) only
 - c) (i) and (iii) only
 - d) (ii) and (iii) only
 - e) (i), (ii) and (iii)

.....

Q7: Which of the following statements about the strong force is true?

- a) The strong force and the gravitational force between two protons in a nucleus are roughly equal in magnitude.
- b) The strong force can act between two protons or two neutrons, but not between a proton and a neutron.
- c) The strong force can act on protons, neutrons and electrons.
- d) The strong force is a short-range force.
- e) The strong force can act over any distance.

1.3 Quarks

In the Standard Model of fundamental particles, hadrons are assembled from basic particles, called quarks. The name quark is borrowed from the book 'Finnegan's Wake', written by James Joyce. Other whimsical terms are used in the Standard Model of fundamental particles. According to this model, the quarks come in different flavours (types). Over the years the structure has been refined and extended. The Standard Model of fundamental particles has now evolved to the point where six flavours of quark are recognised. The flavours are up (u); down (d); strange (s); charm (c); bottom (b) and top (t). Combinations of these flavours (and another quark property called *colour*) account for the variation in all the particles in the hadron group.

Unfortunately the use of the terms *flavour*; *up (u)*; *down (d)*; *strange (s)*; *charm (c)*; *bottom (b)* and *top (t)* may be confusing. They have a totally different meaning from the everyday use of the words. For example, quarks do not have a direction or position.

All mesons are composed of two quarks (a quark and an antiquark, see diagram below). All baryons are composed of three quarks (a combination of quarks and antiquarks, see diagram below). The quark model can successfully account for all known mesons and baryons. For example the pion-plus, which belongs to the meson group, comprises an anti-down quark and an up quark (u). See 1.5 for more information on antimatter, for example \bar{d} . The proton and the neutron, which belong to the baryon group are represented as a combination of the up and down quarks.

The numbers in the diagram below represent the charge carried by each quark compared to the

charge of an electron.

\bar{d} has a charge of $1/3$, which means its charge is positive and equal in magnitude to one third of an electron charge.

u has a charge of $2/3$, which means its charge is positive and equal in magnitude to two thirds of the charge on an electron.

The charge on the pion is therefore $1/3 + 2/3 = 1$, which means its charge is positive and equal in magnitude to the charge on an electron.

Quark diagram of meson, proton and a neutron

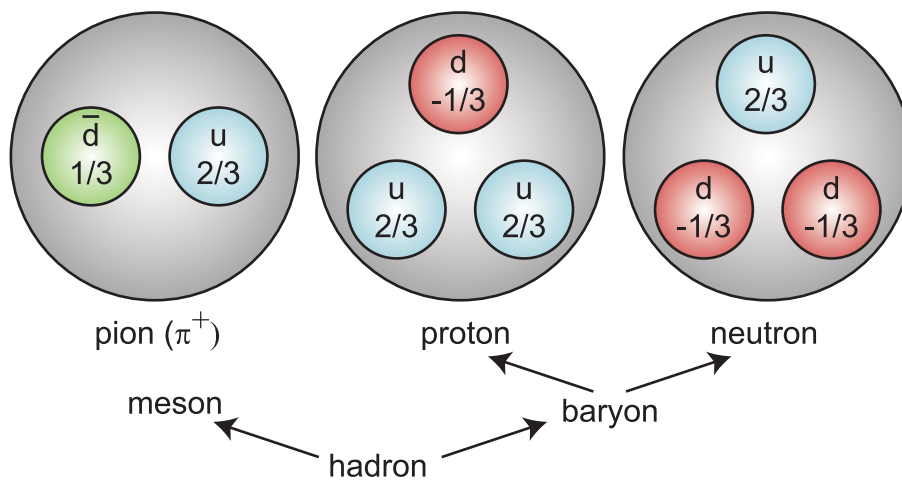

The structure proposes that quarks have a strong affinity for each other. The affinity is enabled through a new kind of charge known as colour charge. Colour charge comes in three shades - red, green and blue. Whatever you do, do not take all of this too literally. The colour ascribed to the quark is not a real colour as such.

Since all mesons are made from the combination of 2 quarks their baryon number must be $2/3$.

Since all baryons are made from the combination of 3 quarks their baryon number must be 1.

Quarks as yet have not been observed directly and evidence for their existence is circumstantial. However, imagining that hadrons comprise quarks brings a structure and order to the events that are witnessed in the bubble chambers and other detectors that are used to view and analyse particle reactions.

The structure requires quarks to have properties not previously allowed for fundamental particles. For example, quarks have fractional electric charges, i.e. charges of $1/3$ and $2/3$ of the electron charge. They also have a baryon number of $1/3$.

Quarks

Quark symbol	Name	Charge	Baryon number
u	up	$2/3$	$1/3$
d	down	$-1/3$	$1/3$
c	charm	$2/3$	$1/3$
s	strange	$-1/3$	$1/3$
t	top	$2/3$	$1/3$
b	bottom	$-1/3$	$1/3$

As has already been stated, the colour is not a real colour as such. It is a concept that has been invented to explain the *periodic table of the particles*. All particles containing quarks are *white*. You mix quark colours in the same way as you mix the primary colours of light. A red, green and blue quark would be present in a white particle. Other combinations of quark colour however are also possible within the structure of the theory. Red and anti-red also give white (anti-red is a mix of green and blue). The theory suggests that colour charge is responsible for the strong interaction between quarks and the interaction is thought to be mediated by exchange of particles carrying colour charge. These particles are called gluons. The theory governing these colour charge combinations of quarks is known as quantum chromodynamics.

1.4 Bosons

In the current view, all matter consists of three kinds of particles: leptons, quarks, and mediators. The mediators are the particles by means of which the interactions involving the four forces are enabled. An analogy for a *mediating particle* is two people passing a ball or a boomerang back and forth to each other. The ball (the mediator) enables a repulsive force to act between the people (the particles) because when the ball hits the person it tends to push the person's head away from the thrower. This must happen in order to ensure momentum is conserved.

The boomerang (the mediator) enables an attractive force to act between the people (the particles) because when the boomerang hits the person it tends to push the person towards the thrower. This must happen in order to ensure momentum is conserved.

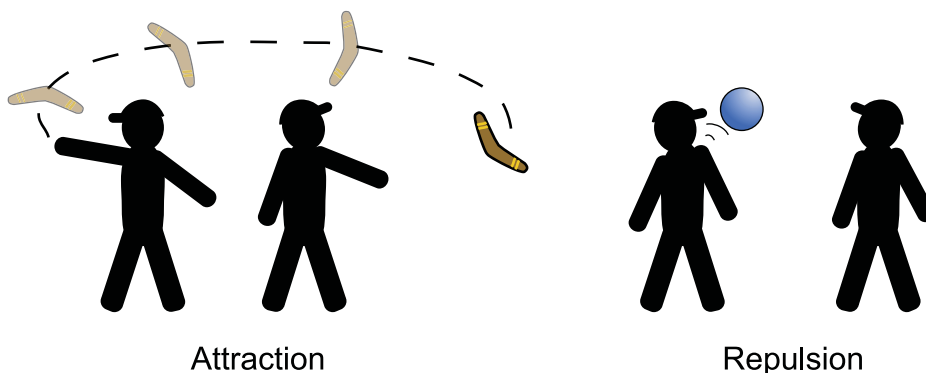

These mediator particles are normally referred to as bosons.

For weak interactions the force is mediated by particles called W and Z bosons.

Recently the Higgs boson has been identified using the large hadron collider at CERN. The Higgs boson is related to the production of mass.

For the strong force the mediator is the gluon, as has already been mentioned.

Current theories propose the graviton as the mediator for the gravitational interaction. However as yet evidence for the graviton has not been observed.

Bosons

Interaction	Boson	Relative rest mass	Charge
strong	gluon	0	0
electromagnetic	photon	0	0
weak	W, Z particles	81, 93	$\pm 1, 0$
production of mass	Higgs	identified in 2012	
gravitational	graviton	not yet identified	

In summary, the structure at the moment is a total of 17 particles. The structure comprises 6 quarks and 6 leptons (collectively referred to as the fermions) and 5 mediators (the force carriers - referred to in the structure as bosons).

1.5 Antimatter and PET scanners

Evidence from experiments carried out in particle accelerators shows that all particles have an antimatter equivalent. For example there is an antimatter equivalent of an electron - a particle called a positron. A positron has the same mass as an electron but has a positive charge. This symmetry is found with all particle/antiparticle pairs.

Some, but not all, electrically neutral particles are their own antiparticle, for example a photon is its own antiparticle.

If a particle meets its antiparticle they annihilate each other - that is their rest mass is converted into energy. When an electron and a positron meet each other two gamma rays are produced. When these two gamma rays are produced they travel in opposite directions to each other. This allows total momentum to be conserved.

There are two standard ways of using symbols for antiparticles. A positron can either be written as e^+ or as \bar{e} . The \bar{e} is pronounced as "e-bar" with the bar showing it is the antiparticle of an electron also known as a positron. Similarly an antiproton, \bar{p} , "p-bar", must have a charge opposite to the charge on a proton. Since a proton has a charge of +1, an antiproton's charge is therefore -1.

One use of antimatter is in medical PET scanners (PET stands for positron emission tomography). A tracer that emits positrons is introduced into the patient's body. When the positrons decay they produce gamma rays which can be detected to produce a 3D image.

If there was a significant amount of antimatter then matter/antimatter annihilations would have destroyed it a long time ago.

1.6 Beta decay

There are two types of beta decay. One type involves the emission of an electron (β^- decay) and a particle called the antineutrino, which is the antiparticle of a particle called the neutrino. The existence of the neutrino was predicted in 1931 by Austrian physicist and Nobel Prize winner, Wolfgang Pauli. Its existence was postulated to account for the variation in the kinetic energy of beta particles during radioactive decay.

Kinetic energy of beta particles during radioactive decay

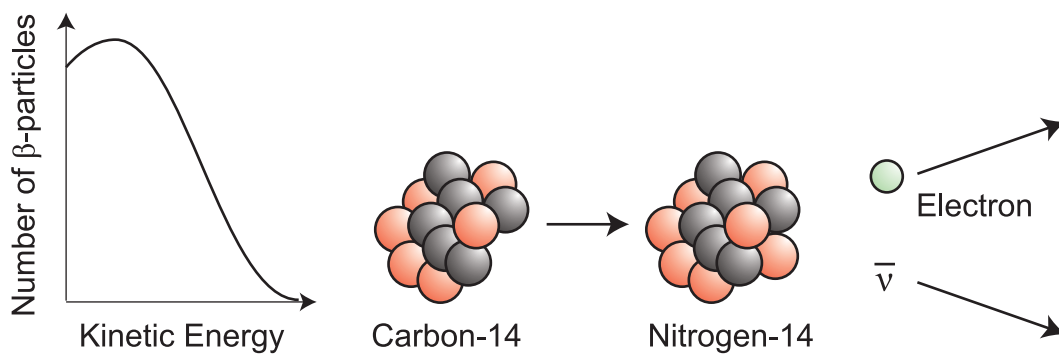

The variation in the kinetic energy of the beta-particles led to the need for a new particle - namely the neutrino and its antiparticle the antineutrino.

In this decay process the missing energy is transferred by an antineutrino.

Without the presence of the neutrino particle there would have been a violation of conservation of energy. So great is the faith in this conservation law that the neutrino particle had to exist, even although at the time it was undetectable. The existence of the neutrino was confirmed in 1956. The second type of beta decay involves the emission of a positron (β^+ decay) and a neutrino. Both β^- and β^+ decay processes are associated with the weak nuclear force.

Whether a nucleus decays by β^- or β^+ emission seems to depend on the ratio of neutrons to protons in the nucleus.

Neutron number N against proton number Z for the nuclides

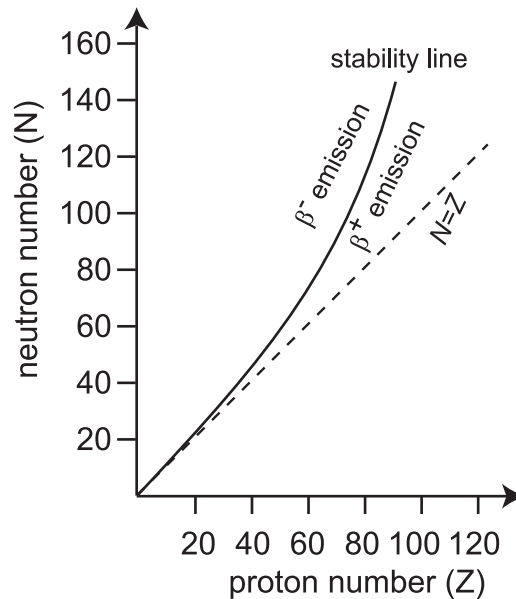

The solid line in the diagram represents the stable nuclides. The ratio N/Z for isotopes to the left of the line (neutron-richer isotopes) is greater than the ratio for isotopes to the right of the line (less neutron-rich; i.e. more proton-rich isotopes). β^- decay is associated with the neutron-richer nuclides and β^+ decay with the less neutron rich (more proton-rich) nuclides.

β^- decay is often referred to as neutron-beta decay. β^+ decay (the decay associated with the proton-richer nuclides) is referred to as proton-beta decay. The quark model accounts for both processes. Let us examine first of all the neutron-beta decay process. It is represented as follows.

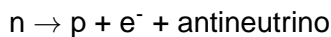

The presence of the antineutrino ensures that the law of conservation of energy and other conservation laws apply in the decay process. The reaction can be represented by a number of stages.

Neutron-beta decay process - first stages

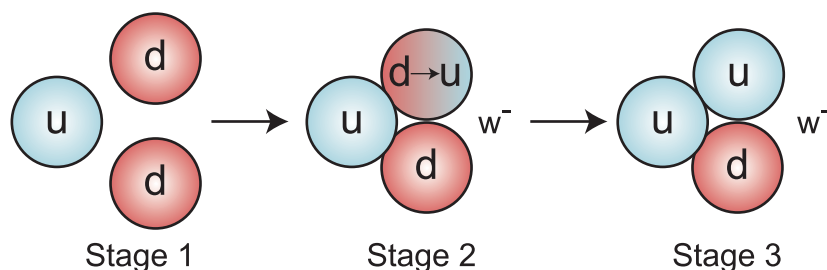

Stage 1: The neutron (charge = 0) is made up of an up quark (u) and two down quarks (dd).

Stage 2: A weak interaction is involved here. One of the down quarks is transformed into an up quark. The down quark has a charge of $-\frac{1}{3}$ and the up quark has a charge of $\frac{2}{3}$. The transformation is mediated by a W^- particle, which carries away a -1 charge.

Stage 3: The new up quark rebounds away from the emitted W^- particle. The neutron now has become a proton.

Neutron-beta decay process - final stages

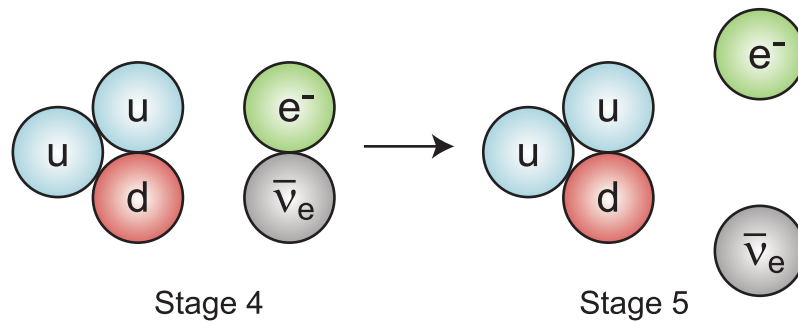

Stage 4: An electron (e⁻) and an antineutrino (ν̄_e) emerge from the W⁻ particle.

Stage 5: The proton, electron, and the antineutrino move away from one another.

The stages 2, 3 and 4 of this process occur in less than a billionth of a billionth of a billionth of a second, and are not observable.

Proton-beta decay

Proton-beta decay is a kind of mirror image of the neutron-beta decay process.

$$p \rightarrow n + e^+ + \text{neutrino}$$

In the proton-beta reaction an up quark in a proton becomes a down quark and the W⁺ mediator particle is emitted. The W⁺ particle produces a positron (e⁺) and a neutrino ν_e.

The quark model and beta decay: Questions

Go online



Q8: Which of the following contains only flavours of quark?

- a) up; down; top; bottom; left; right
- b) top; bottom; glue; colour; left; right
- c) up; down; strange; charm; top; bottom
- d) strange; charm; glue; colour; left; right
- e) strange; charm; up; down; glue; colour

.....

Q9: Which of the following statements about the simple quark model of hadrons is/are correct?

- i. All mesons are composed of three quarks or three antiquarks.
- ii. Baryons are composed of a quark and an antiquark.
- iii. The properties of all hadrons can be described in terms of the simple quark model.

- a) (iii) only
- b) (i) and (ii) only
- c) (i) and (iii) only
- d) (ii) and (iii) only
- e) (i), (ii) and (iii)

.....

Q10: A hydrogen atom consists of one proton, one electron and no neutrons. How many quarks are there in a hydrogen atom?

- a) 0
- b) 1
- c) 2
- d) 3
- e) 4

.....

Q11: Which force is associated with β -decay?

- a) strong force
- b) weak force
- c) gravitational force
- d) electromagnetic force
- e) depends on the atom in which the decay takes place

1.7 Summary

Summary

You should now be able to:

- state that the 3 fundamental particles are quarks, leptons and bosons;
- state that quarks and leptons are the matter particles;
- state that bosons are the force mediating particles;
- state that the quark model includes the properties of charm, topness and bottomness;
- state that the properties of all hadrons can be described in terms of the quark model;
- describe a simple quark model of hadrons in terms of up, down and strange quarks and their respective antiquarks, taking into account their charge, baryon number and strangeness;
- state that there are two groups of hadrons known as baryons and mesons;
- state that all baryons are made of three quarks;
- state that neutrons and protons are examples of baryons;
- state that because protons and neutrons contain constituents called quarks, they are therefore not fundamental particles themselves;
- describe the properties of neutrons and protons in terms of the quark model;

Summary continued

- state that all hadrons are thought to be unstable to some degree and are, consequently, subject to decay;
- state that the strong interaction can be used to explain the forces between hadrons;
- state that the electrical charge of a hadron is conserved during a nuclear reaction;
- state that baryon number is conserved during an interaction;
- state that protons and neutrons are baryons with baryon number 1;
- state that neutrons and protons within a nucleus are relatively stable;
- state that free neutrons are unstable, with a half-life of approximately fifteen minutes, and decay to produce a proton and a beta particle;
- state that the half-life of free protons is thought to be of the order of 10^{32} years;
- state that all mesons are made of two quarks;
- state that pions and kaons are examples of mesons;
- state that electrons and neutrinos are members of a group of fundamental particles known as leptons;
- state that bosons are fundamental particles;
- state that bosons are force mediating particles;
- name the four fundamental forces;
- state that bosons enable these fundamental forces to act;
- state that there are two types of beta decay;
- state that positrons and neutrinos are produced during β^+ decay, and electrons and antineutrinos are produced during β^- decay;
- predict, using a graph showing the neutron-proton ratios within nuclei, whether a decay is likely to result in the emission of a β^+ or a β^- particle;
- describe the two types of beta decay in terms of a simple quark model;
- state that a weak interaction involving quarks is responsible for beta decay.

1.8 Extended information

The authors do not maintain these web links and no guarantee can be given as to their effectiveness at a particular date.

They should serve as an insight into the wealth of information available online and encourage readers to explore the subject further.

Top tip

- Animation for orders of magnitude:
<http://micro.magnet.fsu.edu/primer/java/scienceopticsu/powersof10/>
- PET scanners:
<http://www.patient.co.uk/health/PET-Scan.htm>
- Latest news from CERN:
<http://public.web.cern.ch/public/>
- Under the heading "Big Data, bigger Universe", zoom to where you sit in the scale of all things, plus global snapshots of the Big Data revolution:
<http://www.bbc.co.uk/programmes/b037mkj3>
- An animation showing the combinations of quarks to form hadrons:
<http://www.educationscotland.gov.uk/highersciences/physics/unittwo/standardmodel/standardmodel.asp>
[unittwo/standardmodel/standardmodel.asp](http://www.educationscotland.gov.uk/highersciences/physics/unittwo/standardmodel/standardmodel.asp)
- May be entitled 'Physics for idiots' but has a lot of nonmathematical descriptions that could help you:
<http://www.physicsforidiots.com/particlesandforces.htm>
- Particle adventure:
<http://particleadventure.org/>
- The Standard Model from CERN:
<http://www.exploratorium.edu/origins/cern/ideas/standard3.html>
- 'What is Reality?', a site about the nature of physical reality:
http://www.ipod.org.uk/reality/reality_small_world.asp
- Several CERN teaching resources:
<http://education.web.cern.ch/education/Chapter2/Teaching/PP.html>
<http://education.web.cern.ch/education/Chapter2/Teaching/media.html>
<http://lectureonline.cl.msu.edu/~mmp/applist/q/q.htm>
- History timeline:
<http://particleadventure.org/other/history/index.html>
- A series of films:
<http://www.collidingparticles.com/episode01.html>
- Brian Cox - Building blocks of matter:
<http://www.youtube.com/watch?v=-FWxd78sOZ8>
- Introduction to the world-leading science and technology at STFCL:
<http://www.youtube.com/user/SciTechUK>

1.9 Assessment

End of topic 1 test

Go online



Q12: Select the correct words within the brackets for the following paragraphs concerning fundamental particles.

Fundamental particles are particles which are thought to have no underlying structure. The {electron/proton/antiproton} is an example of a fundamental particle. It belongs to a group of particles called the {leptons/kaons/bosons}.

Particles such as {neutrinos/neutrons/positrons} are not fundamental particles. These particles are members of a group known as the hadrons. The hadrons are divided into two sub-groups called the baryons and the {fermions/kaons/mesons}.

All hadrons comprise combinations of fundamental particles called quarks. The baryons are made up of {two/three/four} quarks. There are six main types of quark. One type is called the up quark, another type is the {top/middle/lower} quark.

.....

Q13: In the radioactive decay of a hadron particle, a quark, Q_A , with $+2/3$ units of charge is transformed to a quark, Q_B , with charge $-1/3$ units. In this decay process, a charged particle, C_p , is released.

The following statement represents this decay. The charge on each of the quarks is shown below the statement.

$$\begin{array}{ccccccc} Q_A & \rightarrow & Q_B & + & C_p & & \\ +2/3 & & -1/3 & & & & \end{array}$$

- a) How many units of charge will be removed from the particle as a result of the decay process?
- A) $+2/3$
 - B) +1
 - C) -1
 - D) +2
 - E) $-1/3$
- b) Which of the following particles is emitted in the decay process?
- A) Up quark
 - B) Positron
 - C) Alpha particle
 - D) Down quark
 - E) Electron
- c) Which of the following interactions is involved in the decay process?
- A) Strong
 - B) Weak
 - C) Gravitational
 - D) Electromagnetic
 - E) Electrostatic

.....

Q14: The up quark has $+\frac{2}{3}$ units of charge. The down quark has $-\frac{1}{3}$ units of charge.

An up quark is represented by the symbol u and a down quark by the symbol d .

The antiquarks of the u and d quarks have symbols \bar{u} and \bar{d} respectively.

- a) Which of the following combinations of quarks could constitute an antiproton?
- A) $\bar{u} \bar{u} \bar{d}$
 - B) $\bar{u} \bar{d} \bar{d}$
 - C) $u \bar{d} \bar{d}$
 - D) $\bar{u} d d$
 - E) $u u \bar{d}$
- b) The π^- particle carries a charge of -1 units and is a member of the meson family. Which of the following combinations of quarks could constitute a π^- particle?
- A) $d \bar{u}$
 - B) $\bar{d} u$
 - C) $\bar{u} \bar{d}$
 - D) $\bar{d} \bar{u} \bar{u}$
 - E) $\bar{d} \bar{d} \bar{u}$

Topic 2

Forces on charged particles

Contents

2.1	Electric fields	23
2.1.1	Hazards due to electric fields	25
2.1.2	Uses of electric fields	28
2.2	Work done and potential difference	29
2.2.1	Potential difference and the volt	29
2.2.2	The cathode ray tube	30
2.2.3	Quiz on work done and potential difference	32
2.3	Magnetic effects of current	33
2.3.1	Magnetic forces and fields	34
2.3.2	Magnetic field patterns	38
2.3.3	Charged particles moving in a magnetic field	42
2.3.4	Particle accelerators	43
2.4	Summary	48
2.5	Extended information	48
2.6	Assessment	49

Learning objective

By the end of this topic you should be able to:

- describe what is meant by an electric field;
- use field lines to describe electric fields;
- explain that work is done when a charge is moved in an electric field;
- explain what is meant by potential difference;
- carry out calculations using the relationship between work done in joules, charge in coulombs and potential difference in volts;
- explain the motion of charged particles in electric fields;
- state the condition necessary for a magnetic force to exist between two charged particles;
- describe the magnetic force by using a field description;
- recognise the magnetic field patterns caused by current in a long straight wire, a flat circular coil and a long solenoid;
- be able to describe the operation of different types of particle accelerators.

In this topic we will examine electric fields and potential difference (voltage). This will include a description of how electric charges are affected by a magnetic field.

We will then look at how electric fields are used to probe the nature of matter inside particle accelerators.

2.1 Electric fields

You may have noticed crackling and perhaps seen sparks when taking off a nylon shirt or blouse in the dark. You will have seen lightning. You will certainly have used electrical appliances of all kinds. All of these depend on a fundamental property of matter - charge.

In this topic we look at how charge can only be described by its properties and in particular how charges exert forces on each other - the electric force. One convenient way we have of describing the forces that charges exert on each other is by introducing the concept of an electric field. You will have already met the term 'potential difference'. This term is explained in this Topic in terms of the work done in moving a charge in an electric field. We also look briefly at some applications of charges and fields.

Thales, an ancient Greek experimenter, noticed that when he rubbed amber with cloth, the amber attracted small pieces of straw - it exerted a force on the straw. This effect was described about 2000 years later as being due to a *charge* of electricity. The word *electricity* comes from the Greek word *elektron* meaning amber. The idea of charge originated because it was first thought that electricity was like a fluid that could be poured. We still sometimes say 'charge your glasses' meaning fill them up with drink.

We now know that charge is a fundamental property of matter. The magnitude of the charge carried by one electron or one proton is known as the fundamental unit of charge, e . This means that charge is quantised, or comes in multiples of this fundamental charge. Experiments have shown that there are only two types of charge. More than 200 years ago these two types were called *positive* and *negative* by the American physicist Benjamin Franklin.

An object can be charged by adding negatively-charged particles such as electrons to it, in which case it becomes negatively charged, or by removing electrons from it, making it positively charged. Further experiments have shown that a negatively-charged object attracts a positively-charged object and that objects that have similar charges repel each other.

We have just noted that charged objects attract or repel each other. In other words, charges exert attractive or repulsive (repelling) forces on each other. A convenient way of describing this electric force is to use the concept of the electric field. An electric field is the region around a charged object where the charge exerts a force on other charges.

It is usual to represent an electric field by using lines of force. The strength of the electric field at any point is shown by the separation of the lines of force, the closer the lines the stronger the electric field. The direction is shown by arrowheads on the lines, pointing the way a positive charge would experience a force in the field.

The electric field lines around a point charge are radial. The electric field around an isolated point charge is shown in Figure 2.1. The actual number of lines drawn is not significant - only their relative closeness gives an indication of the strength of the electric field. This shape of field is called a radial field.

Figure 2.1: Electric field around (a) an isolated positive charge, and (b) an isolated negative charge

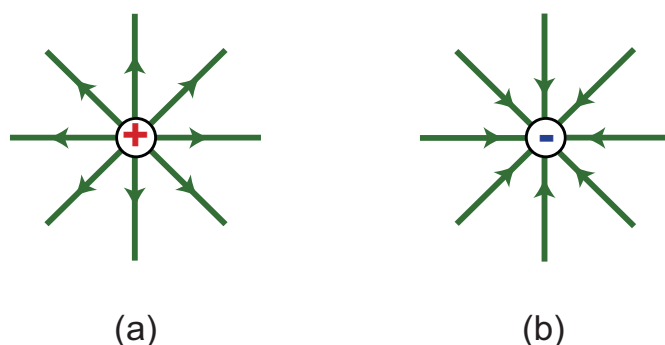

You might recognise that this shape of field is similar to the gravitational field around the Earth. The gravitational field strength g is a measure of the gravitational force of attraction on a mass. It is measured in newtons per kilogram. Near the Earth's surface g has the approximate value 9.8 N kg^{-1} . It decreases as the distance from the Earth's surface increases. In a similar way, electric field strength is a measure of the electrical force on a charge. The units of electric field strength are newtons per coulomb (N C^{-1}).

An equivalent unit, the volt per metre (V m^{-1}) is also frequently used. A radial field is a non-uniform field. Figure 2.2 shows the field between a pair of charged metal plates, which is a uniform field between the plates.

Figure 2.2: Electric field between two charged metal plates

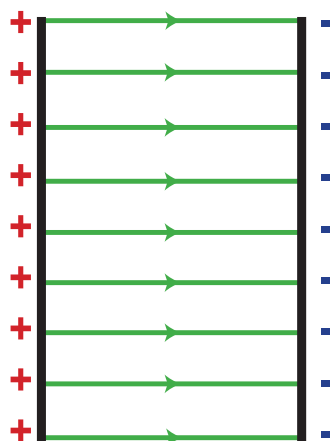

Since the electric field between the two charged metal plates is uniform the force experienced by a charged particle would have exactly the same value at any point within the area where the field lines are parallel.

Note:

1. Field lines have an arrow + to - because that is the direction of the force experienced by a positively charged particle that is placed in the field.
2. Field lines always touch the charged surface at 90° .
3. Field lines never cross.
4. The closer together field lines are the stronger is the electric field.

A conductor is a material through which electric charge can flow. This is because there are free electric charges in a conductor. If an electric field is applied to a conductor, the charges experience a force, and this force causes the free electric charges in the conductor to move.

Electric field patterns

[Go online](#)

Electric field patterns:

1. between two point charges of similar charge;

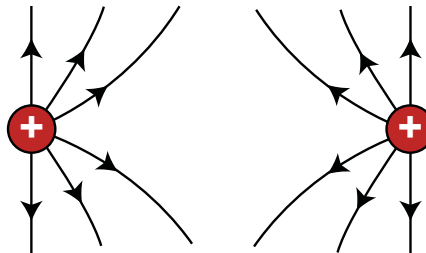

2. between two point charges of opposite charge;

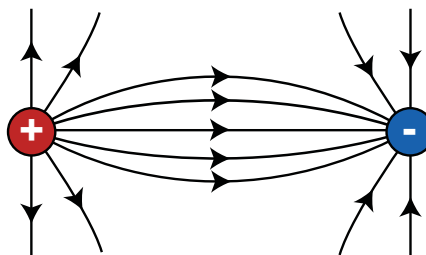

3. between two parallel metal plates with opposite charges.

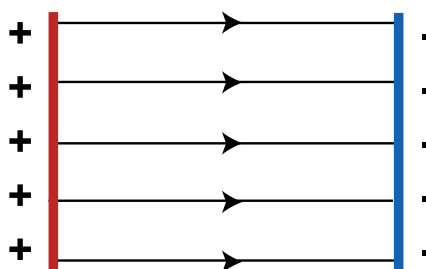

2.1.1 Hazards due to electric fields

Electric fields can be hazardous. The most obvious example of a hazard caused by an electric field is thunder and lightning but there are other less obvious cases.

Microchips can be easily damaged by electrostatic discharges. If a person has a charge on their body (this could be caused by something as simple as walking across a carpet) and touches a printed circuit board they can discharge through the microchips on the board. This can cause the chips to be damaged and stop them working. Often a person is unaware of the discharge as a relatively small voltage will destroy the microchips.

Computer engineers overcome this difficulty by wearing a wrist strap. This strap has a metal plate that sits against the person's skin and a lead that is attached to an earth point. The earth point is often simply the metal case of the computer that is being worked on.



http://en.wikipedia.org/wiki/File:Antistatic_wrist_strap.jpg by <http://en.wikipedia.org/wiki/User:Kms> licensed under <http://creativecommons.org/licenses/by/3.0/deed.en>

Computer engineers often also use special antistatic floor mats to prevent a build up of static charge.

Charges, forces and fields: Questions (15 min)

Go online



Useful data:

fundamental charge e	$1.60 \times 10^{-19} \text{ C}$
------------------------	----------------------------------

Q1: How many protons are needed to carry a charge of 1 C?

- a) 1.6×10^{-19}
- b) 8.85×10^{-12}
- c) 1
- d) 6.25×10^{18}
- e) 1.6×10^{19}

.....

Q2: Two metal spheres are hanging from nylon threads. When the spheres are brought close together they repel each other. Which one of the following statements could be true?

- a) One sphere is negatively charged, the other is positively charged.
- b) One sphere is uncharged, the other is positively charged.
- c) One sphere is uncharged, the other is negatively charged.
- d) Both spheres are uncharged.
- e) Both spheres are positively charged.

.....

Q3: When a positive charge is placed in an electric field it

- a) experiences a force.
- b) loses its charge.
- c) moves in a circle.
- d) becomes a negative charge.
- e) doubles its charge.

.....

Q4: Which of the following shows the electric field round an isolated negative charge?

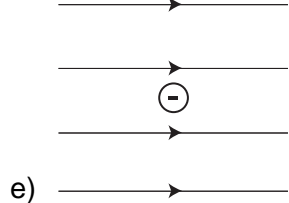
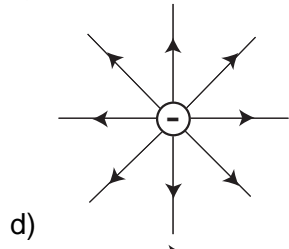
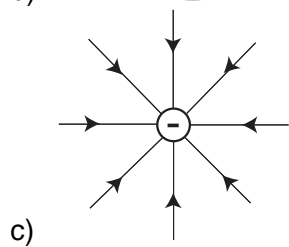
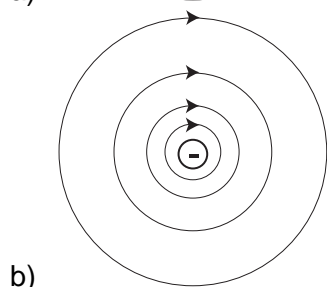
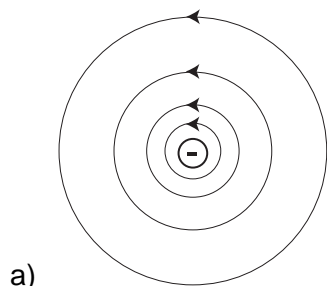

2.1.2 Uses of electric fields

Precipitators

Some industrial processes require a very clean environment, for example the production of microchips. The air in a factory can have fine particles of dust removed from it by using an electrostatic precipitator. The air in the factory is passed through a filter that contains an electric field. Fine particles of dust will be attracted to the plates producing the electric field and hence be removed from the air.

Xerography

Xerography is a dry photocopying method. This is how both photocopiers and laser printers work. The drum of the photocopier/printer carries an electric charge. When a document is scanned the blank parts of the document cause the corresponding areas of the drum to lose their charge. Toner (carbon powder) is then sprayed on to the drum but only sticks to the drum where there is a charge. Paper is then passed over the drum and the toner fixes on to the paper.

Paint spraying

Some paint spray guns use electrostatics to produce an even coat of paint. When the paint spray is produced the tiny drops of paint are each given the same electrical charge. This means that the drops of paint all repel each other so that an even coat of paint is produced on a surface.

Inkjet printers

Some inkjet printers use electric fields to direct the ink to the appropriate section of the page. As the ink passes through the spray nozzle it is charged by an electrode. The charged ink droplets are then deflected by an electric field so they land at the correct point on the printed page. This idea was first patented well over 100 years ago by Lord Kelvin.

Schematic representation of an inkjet printer

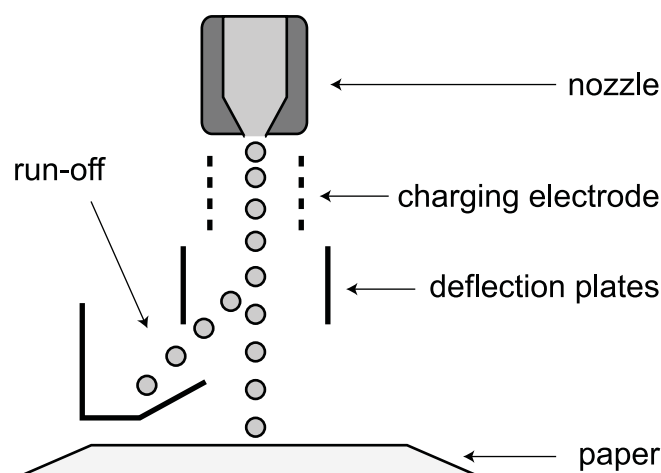

Electrostatic propulsion

Some spacecraft use electric fields to provide force so that they can be manoeuvred in space. These devices accelerate ions in an electric field. This produces a force on the spacecraft and so its motion can be altered. At the moment these devices only produce very small forces and so are used to change the position or course of the spacecraft.

2.2 Work done and potential difference

This section begins by looking at potential difference and the volt and then examines cathode ray tubes.

2.2.1 Potential difference and the volt

Consider a positively-charged particle placed in the uniform electric field set up between two parallel metal plates as shown in Figure 2.3.

Figure 2.3: A charge being moved in an electric field

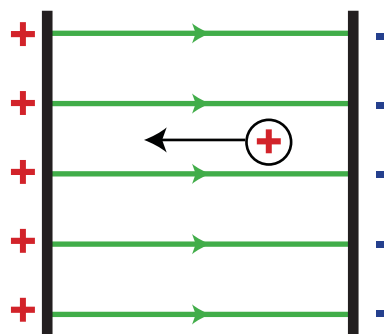

Work would need to be done to move a positive charge to the left in this field. This is because the electric field exerts a force to the right on the charge.

This work done is stored in the electric field as electrical potential energy. When the charge has been moved to the left-hand plate, the electrical potential energy stored by the electric field has increased.

The greater the electrical potential energy, the greater is the potential difference between the metal plates.

The **potential difference** between the two plates is a measure of the work done in moving the charge between the two plates. This is used to define the unit of potential difference, the volt, as follows:

If one joule of work W is done in moving one coulomb of charge Q between two points, the potential difference V between the two points is one volt. So

$$V = \frac{W}{Q}$$

Where V is the potential difference in volts, W is the work done (or the energy) in joules, and Q is the charge in coulombs.

1 volt = 1 joule per coulomb.

If a charged particle is placed in an electric field, then the field will do work on the particle in moving it. In this case, the particle gains an amount of energy equal to the amount of work done by the field.

We have already compared the electric field around a charge with the gravitational field around the Earth. We can take this comparison further.

At the top of a mountain there is a greater gravitational potential than at the bottom.

This means that work has to be done and energy has to be used up in moving a mass up a mountain. This work is done against the gravitational field and is stored in the mass as gravitational potential energy. If the mass is allowed to fall down the hill, the potential energy of the mass decreases. The difference in heights between the top of the hill and the bottom (*not* the actual heights relative to some base line such as sea level) determines the amount of gravitational potential energy.

In a similar way, it is the potential difference between the plates that determines the amount of energy needed to move the charge from one plate to the other, not the voltage of either plate relative to, for example, earth potential.

Example A proton is accelerated in a uniform electric field set up by a potential difference of 500 V.

Calculate the energy gained by the proton.

We know that the charge on a proton is 1.6×10^{-19} C, so using $W = QV$

$$W = QV$$

$$W = 1.6 \times 10^{-19} \times 500$$

$$W = 8 \times 10^{-17} \text{ J}$$

2.2.2 The cathode ray tube

Cathode ray tubes used to be very common. Televisions and computer monitors up to about the year 2000 were nearly always made using a cathode ray tube. This meant that these devices were very large. The advent of LCD, LED and plasma screens means that cathode ray tubes have nearly all disappeared from people's homes. However the cathode ray tube is still valuable as a tool for studying electric fields and as an introduction to particle accelerators.

In a cathode ray tube, such as is shown in Figure 2.4, electrons ('cathode rays') are freed from the heated cathode. (The electrons were originally called cathode rays because these experiments were first carried out before the electron was discovered. To the original experimenters it looked like the cathode was emitting energy rays.) These electrons are accelerated while in the electric field set up between the cathode and the anode, gaining kinetic energy. Some electrons pass through a hole in the anode. From the anode to the y-plates, the electrons travel in a straight line at constant speed, obeying Newton's first law of motion.

Figure 2.4: The cathode ray tube

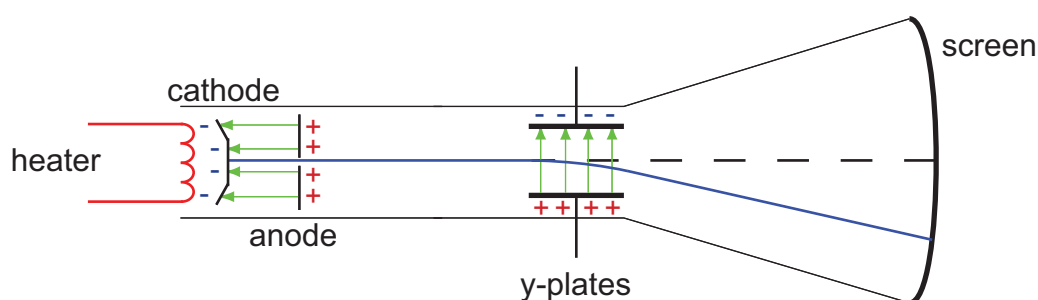

A second electric field is set up between the y -plates, this time at right angles to the initial direction of motion of the electrons. This electric field supplies a force to the electrons at right angles to their original direction. The resulting path of the electrons is a parabola. The motion of the electrons while between the y -plates is similar to the motion of a projectile thrown horizontally in a gravitational field.

When they leave the region of the y -plates, the electrons again travel in a straight line with constant speed (now in a different direction), eventually hitting the screen as shown.

The point on the screen where the electrons hit is determined by the strength of the electric field between the y -plates. This electric field strength is in turn determined by the potential difference between the y -plates. So the deflection of the electron beam can be used to measure a potential difference.

Example The potential between the cathode and the anode of a cathode ray tube is 200 V.

Assuming that the electrons are given off from the heated cathode with zero velocity and that all of the electrical energy given to the electrons is transformed to kinetic energy, calculate

1. the electrical energy gained by an electron between the cathode and the anode.
2. the horizontal velocity of an electron just as it leaves the anode.

(The mass of an electron is 9.11×10^{-31} kg)

1. The electrical energy gained by an electron is equal to the work done by the electric field between the cathode and the anode, so

$$W = QV$$

$$W = 1.6 \times 10^{-19} \times 200$$

$$W = 3.2 \times 10^{-17} \text{ J}$$

2. If all of this energy is transformed to kinetic energy, then

$$E_k = \frac{1}{2}mv^2$$

$$3.2 \times 10^{-17} = \frac{1}{2} \times 9.11 \times 10^{-31} \times v^2$$

$$v = 8.4 \times 10^6 \text{ m s}^{-1}$$

The cathode ray tube (10 min)

Go online

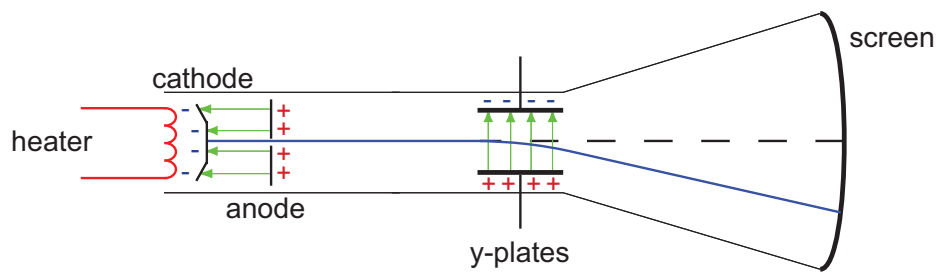

This activity allows you to see the path of electrons in the electric field set up between the cathode and the anode in a cathode ray tube, and calculate the kinetic energy gained by an electron. It also allows the path of the electrons to be changed by applying a potential difference between the y-plates.

Electrons given off from a heated cathode in a cathode ray tube are accelerated by the electric field set up between the cathode and the anode.

The path of the electrons can be changed by the electric field set up by applying a potential difference between the y-plates.

It is important to realise that increasing the potential difference between the cathode and the anode increases the speed of the electrons in the cathode ray. Altering the potential difference between the Y-plates affects the position where the electrons hit the screen.

2.2.3 Quiz on work done and potential difference

Work done and potential difference: Questions (15 min)

Go online



Useful data:

fundamental charge e	$1.60 \times 10^{-19} \text{ C}$
mass of electron	$9.11 \times 10^{-31} \text{ kg}$

Q5: The potential difference between two points is

- a measure of the work done in moving one coulomb of charge between the two points.
 - a measure of the electrical force on a charge of one coulomb.
 - the gravitational potential energy between the points measured in joules.
 - equal to the fundamental unit of charge, in coulombs.
 - the region between the two points where charges exert forces, in newtons.
-

Q6: Which of the following is equivalent to the volt?

- joule per kilogram
- newton per kilogram
- joule per newton

- d) coulomb per kilogram
- e) joule per coulomb

.....

Q7: How much energy is needed to move a charge of 5×10^{-3} C through a potential difference of 8 kV?

- a) 4.0×10^7 J
- b) 1.6×10^6 J
- c) 40 J
- d) 4.0×10^{-5} J
- e) 6.3×10^{-7} J

.....

Q8: A uniform electric field uses up 1.92×10^{-16} J of work in moving an oil drop containing 40 excess electrons between two points in the field.

What is the potential difference between the points?

- a) 4.8×10^3 V
- b) 30 V
- c) 1.2 V
- d) 3.4×10^{-2} V
- e) 1.2×10^{-3} V

.....

Q9: An electron is accelerated from rest by a potential difference of 50 V.

What is the final velocity of the electron?

- a) 8.0×10^{-18} m s⁻¹
- b) 4.2×10^{-6} m s⁻¹
- c) 2.4×10^{-5} m s⁻¹
- d) 4.2×10^6 m s⁻¹
- e) 5.7×10^6 m s⁻¹

2.3 Magnetic effects of current

We are all familiar with permanent magnets and the fact that they exert forces on each other, as well as on certain types of metal and metallic ores. The first descriptions of magnetic effects were made in terms of **magnetic poles**. Every magnet has two poles. Unlike or opposite magnetic poles exert forces of attraction on each other, while like or similar poles repel each other. In addition, both poles of a magnet exert forces of attraction on unmagnetised iron. One pole is called the north pole or N-pole (actually short for 'north-seeking' pole). It points approximately towards the north geographic pole of the Earth. The other end is called the south pole (S-pole). This alignment happens because the Earth is itself a magnet, with a south magnetic pole near to the north geographic pole.

It is tempting to compare north and south magnetic poles with positive and negative charges. While there are similarities, the major difference is that it is possible for isolated positive and negative charges to exist but there is no evidence to suggest that an isolated magnetic pole (a monopole) can exist.

Magnetic forces are used in many familiar devices. The electric motor, the moving coil meter and the TV are amongst the most common. Other areas that use magnetic forces are fusion plasma confinement, the mass spectrometer, charged particle accelerators and magnetrons.

In this section we will discuss how a magnetic force is caused by movement of charges. We will then describe the magnetic force by using a field description. Finally, we will look at current-carrying conductors and use the magnetic field description to explain the forces that they exert on each other.

2.3.1 Magnetic forces and fields

An electric force exists between two or more charged particles whether they are moving or not.

Whenever a charge is moving, a magnetic field is set up around the moving charge. When they are moving, an additional force that is dependent on their velocities is also found to operate. This force is called a magnetic force.

It is usual to describe the interaction between two magnets by applying a field description to them. We can consider that one magnet sets up a **magnetic field** and that the other magnet is in this magnetic field. A magnetic field is usually visualised by drawing magnetic field lines. Figure 2.5 shows the field pattern around a bar magnet.

Figure 2.5: The field pattern around a bar magnet

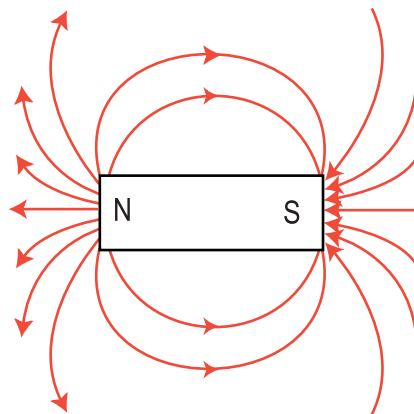

The following points should be noted about magnetic field lines:

- they show the direction in which a compass needle would point at any position in the field;
- they are always shown with a direction of north to south;
- they never cross over each other because the direction of the magnetic field is unique at all points - crossing field lines would mean that the magnetic field pointed in more than one direction at the same place - obviously impossible;

- they are three-dimensional, although this cannot be represented properly on a page - because the magnetic field they represent is three-dimensional;
- they indicate the magnitude of the magnetic field at any point - the closer the lines are together, the stronger is the field;
- like electric field lines, magnetic field lines are used to visualise the magnitude and the direction of the field. Also like electric field lines, they do not exist in reality.

An atom consists of a nucleus surrounded by moving electrons. Since the electrons are charged and moving, they create a magnetic field in the space around them. An electron also has a property called spin which means it behaves as though it is a small spinning ball of negative charge. So there is also a magnetic field associated with the spin of an electron. Some atoms have magnetic fields associated with them and behave like magnets. Iron, nickel and cobalt belong to a class of materials that are **ferromagnetic**. In these materials, the magnetic fields of atoms line up in regions called **magnetic domains**. If the magnetic domains in a piece of ferromagnetic material are arranged so that most of their magnetic fields point the same way, then the material is said to be a magnet and it will have a detectable magnetic field.

Each small arrow represents the magnetic field in a magnetic domain.

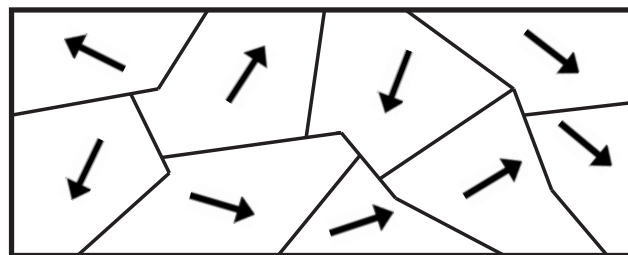

Domains before magnetisation

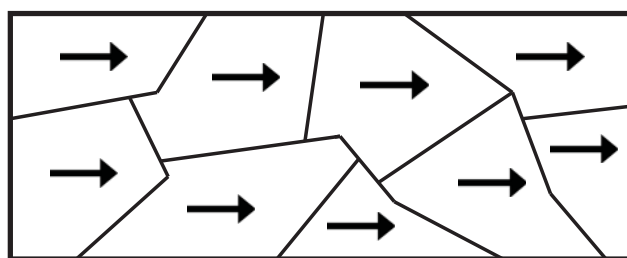

Domains after magnetisation

The Earth's magnetic field is thought to be caused by currents in the molten core of the Earth. A simplified view of the Earth's magnetic field is that it is similar to the field of a bar magnet. This means that the field lines are not truly horizontal at most places on the surface of the Earth, the angle to the horizontal being known as the magnetic inclination.

The Earth's magnetic field at the poles is vertical. A compass needle is simply a freely-suspended magnet, so it will point in the direction of the Earth's magnetic field at any point. The fact that the magnetic and geographic poles do not exactly coincide causes a compass needle reading to deviate from geographic north by a small amount that depends on the position on the Earth. This difference is known as the magnetic declination or the magnetic variation.

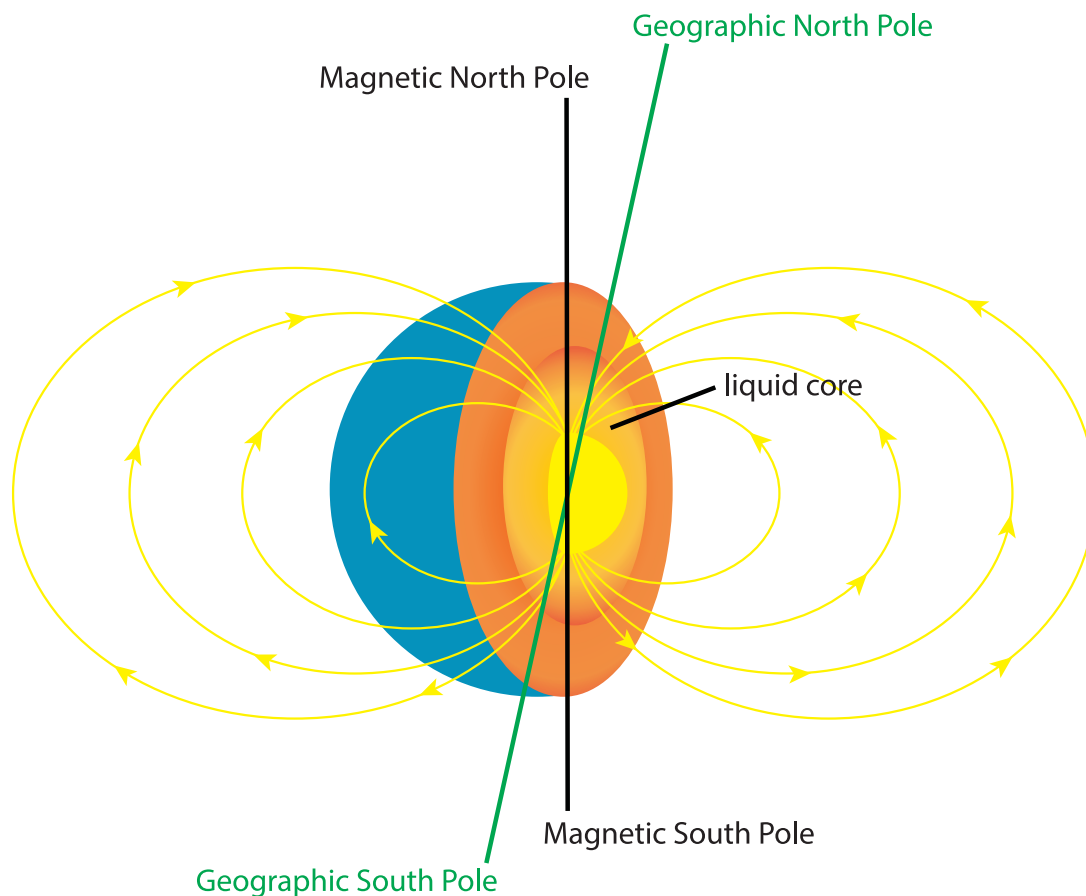

In the same way that we introduced the concept of the gravitational field associated with a mass in an earlier Topic, we can explain magnetic interactions by considering that moving charges or currents create magnetic fields in the space around them, and that these magnetic fields exert forces on any other *moving* charges or currents present in the field.

Magnetic fields and forces: Questions (20 min)

Go online



Q10: Which one of the following statements about magnets is correct?

- a) All magnets have one pole called a monopole.
- b) All magnets are made of iron.
- c) Ferromagnetic materials cannot be made into magnets.
- d) All magnets have two poles called positive and negative.
- e) All magnets have two poles called north and south.

.....

Q11: Which of the following statements about magnetic field lines is/are correct?

Magnetic field lines:

- i. are directed from the north pole to the south pole of a magnet.
- ii. only intersect at right angles.
- iii. are further apart at a weaker place in the field.

- a) (i) only
 - b) (ii) only
 - c) (iii) only
 - d) (i) and (ii) only
 - e) (i) and (iii) only
-

Q12: Which of the following statements about the Earth's magnetic field is/are correct?

The Earth's magnetic field:

- i. is horizontal at all points on the Earth's surface.
- ii. has a magnetic north pole at almost the same point as the geographic north pole.
- iii. is similar to the field of a bar magnet.

- a) (i) only
 - b) (ii) only
 - c) (iii) only
 - d) (i) and (iii) only
 - e) (i), (ii) and (iii)
-

Q13: Which of the following fields act(s) on a stationary, positively-charged particle?

- i. electric
- ii. gravitational
- iii. magnetic

- a) (i) only
 - b) (ii) only
 - c) (iii) only
 - d) (i) and (ii) only
 - e) (i) and (iii) only
-

Q14: Which of the following fields act(s) on a moving, negatively-charged particle?

- 1. electric
- 2. magnetic
- 3. gravitational

- a) (i) only
- b) (ii) only
- c) (iii) only
- d) (i) and (ii) only
- e) (i), (ii) and (iii)

2.3.2 Magnetic field patterns

Current is a movement of charges. We have just seen that there is a magnetic field round about moving charges, so there must be a magnetic field round a wire carrying a current. This effect was first discovered by the Danish physicist Hans Christian Oersted (1777 - 1851). Oersted was in fact the first person to link an electric current to a magnetic compass needle.

Oersted's experiment (15 min)

Go online

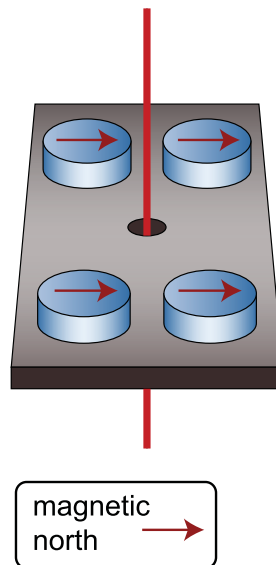

When there is no current, there is no magnetic field around the wire and the compass needles react to the magnetic field around the earth.

A current is now passed through the wire.

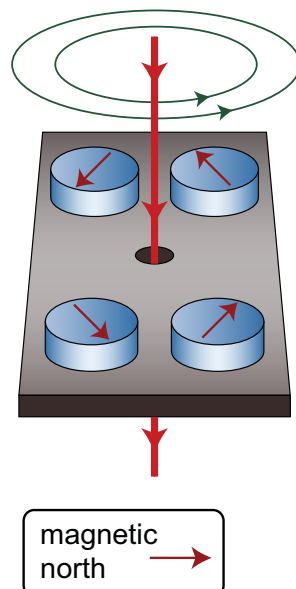

When the current is switched on what is the shape of the magnetic field?

The magnitude of the current is now increased.

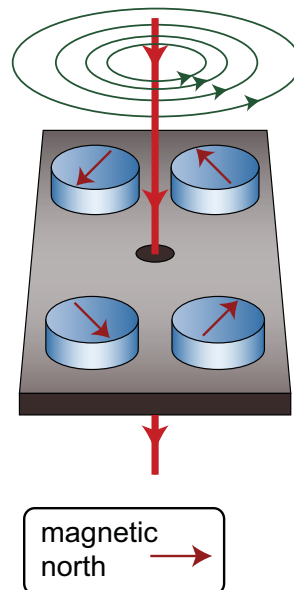

When the current is increased what happens to the strength of the magnetic field?

The direction of the flow of current is now reversed.

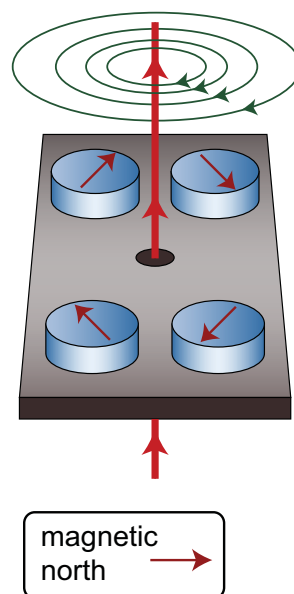

When the current is reversed what happens to the direction of the magnetic field?

A current through a wire produces a circular field, centred on the wire as shown in Figure 2.6. I shows the direction of electron current flow (current flows in the direction negative to positive).

Figure 2.6: The magnetic field around a straight wire

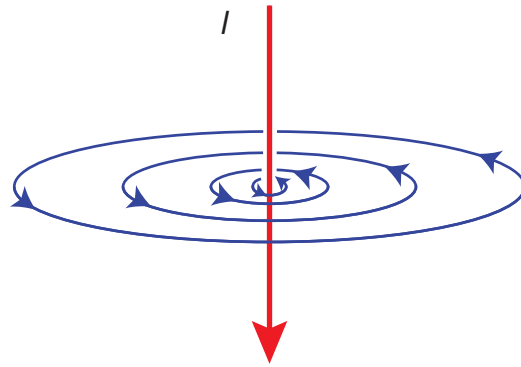

The direction of the magnetic field can be found by using the left-hand grip rule (for electron current), as follows:

Point the thumb of the left hand in the direction of the current. The way the fingers curl round the wire when making a fist is the way the magnetic field is directed. This rule is sometimes known as the left-hand grip rule.

Figure 2.7: The left-hand grip rule for electron current

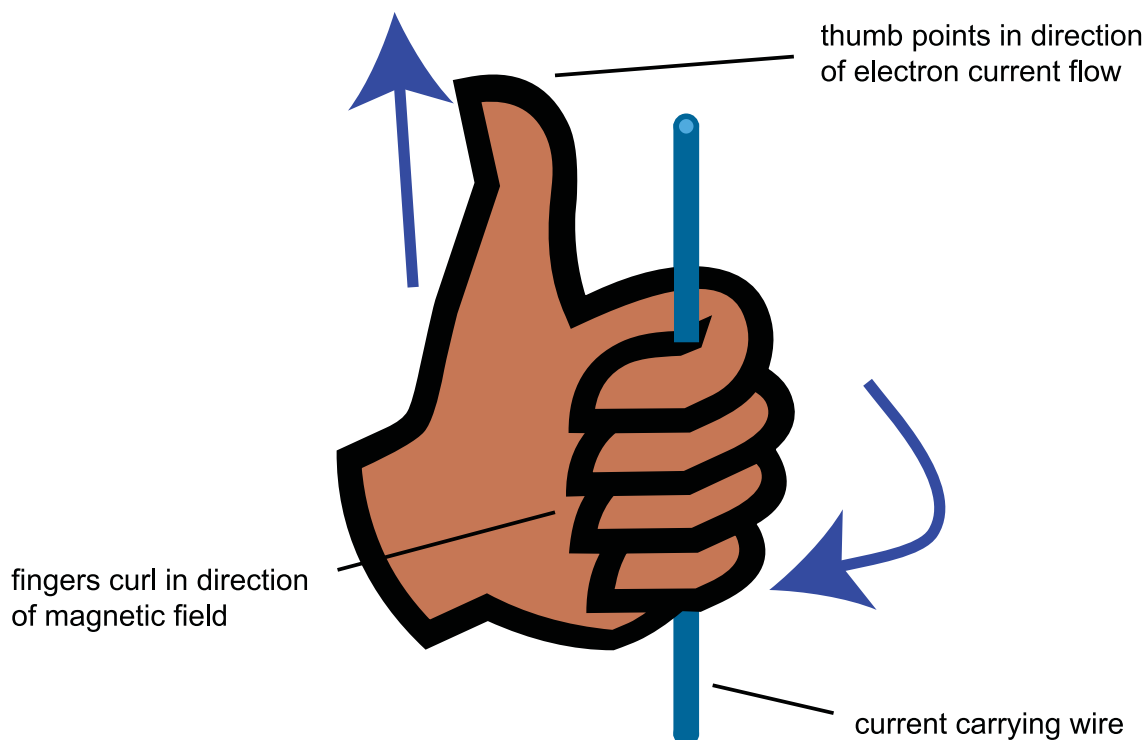

The magnetic field associated with a single straight length of wire is not very strong. If the wire is shaped into a flat circular coil, then the magnetic field inside the coil is more concentrated. The field pattern caused by a current in a flat circular coil of wire is shown in Figure 2.8.

Figure 2.8: The magnetic field pattern caused by current in a flat circular coil

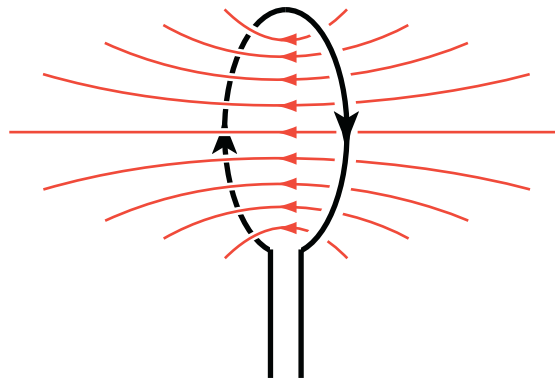

The magnetic field can be further strengthened by winding a wire into a long coil, known as a solenoid. The magnetic field pattern caused by current in a long solenoid is shown in Figure 2.9. Another version of the left-hand grip rule can be used to predict the direction of the magnetic field associated with both the flat circular coil and the long solenoid.

In this case, curl the fingers of the left hand round the coil or the solenoid in the direction of the electron current. The thumb then points towards the north end of the magnetic field produced in the solenoid. See Figure Figure 2.8, Figure 2.9 and Figure 2.10.

Figure 2.9: The left-hand rule for solenoids

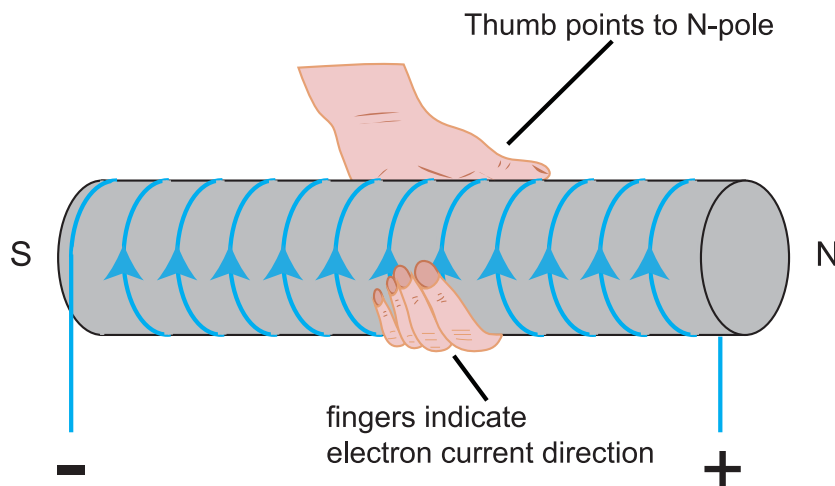
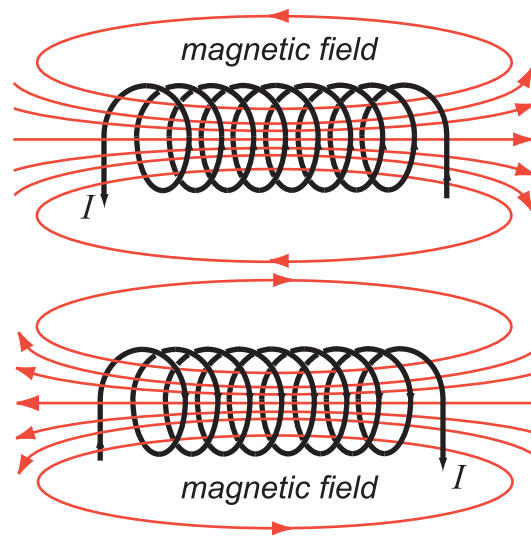

Figure 2.10: The magnetic field pattern caused by current in a long solenoid



2.3.3 Charged particles moving in a magnetic field

When an electron moves through a magnetic field it experiences a force. This is because the movement of the electron is itself producing a magnetic field. The two magnetic fields interact with each other and cause the electron to change direction.

The direction of the force applied to the electron can be worked out using the right hand rule.

Arrange the thumb, forefinger and second finger of your right hand as shown in Figure 2.11.

Figure 2.11: The right hand rule

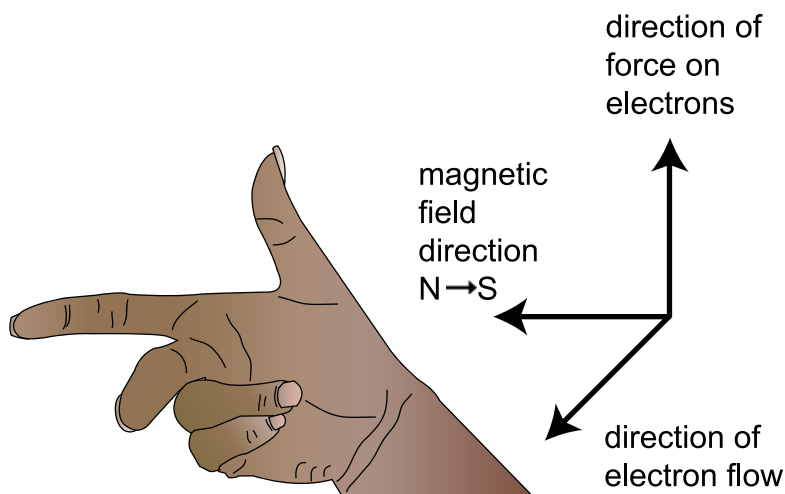

If the second finger points in the direction the electrons are flowing and the first finger points from north to south in the magnetic field then the thumb gives the direction of the force acting on the electrons.

Some people remember this right-hand rule as

- Thumb for thrust (force)

- Fore Finger for Field, $N \rightarrow S$
- Centre finger for current

The right hand rule can also be used to give the direction of the force on positive charged particles. The force on a positive particle will be in the opposite direction to that on an electron (or any negatively charged particle).

2.3.4 Particle accelerators

Particle accelerators are tools that are used to prise apart the nuclei of atoms and thereby help us increase our understanding of the nature of matter and the rules governing the particles and their interaction in the sub atomic world. Particle accelerators are massive machines that accelerate charged particles (ions) and give them enough energy to separate the constituent particles of the nucleus. They have played a significant part in the development of the standard model.

We have already met a very simple particle accelerator: the cathode ray tube. In a cathode ray tube electrons are accelerated by an electric field.

The cathode ray tube however cannot produce high enough energies to investigate the structure of matter. Larger and much more powerful particles have been developed for this purpose.

Particle accelerators are of two main types.

One type accelerates the particle in a straight line. This type is called a linear accelerator, sometimes referred to as a "linac".

The other type accelerates the particle in a circular path. The cyclotron and the more widely used synchrotron are examples of this type.

The linear and circular accelerators both use electric fields as the means of accelerating particles and supplying them with energy.

Linear accelerator

In a linear accelerator, the particle acquires energy in a similar way to the electron in the cathode ray tube but the process is repeated a large number of times. A large alternating voltage is used to accelerate particles along in a straight line.

Figure 2.12: A linear accelerator

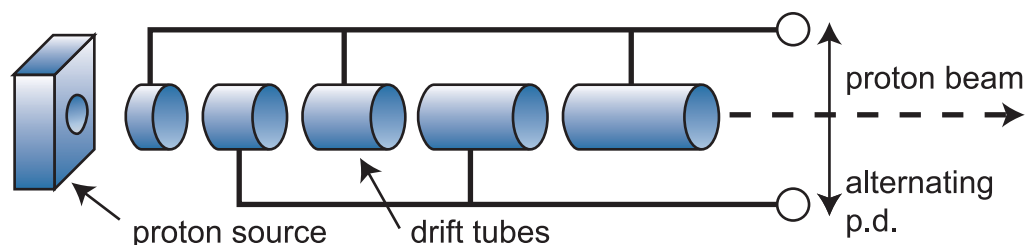

The particles pass through a line of hollow metal tubes enclosed in a long evacuated cylinder. The frequency of the alternating voltage is set so that the particle is accelerated forward each time it goes through a gap between two of the metal tubes. The metal tubes are known as drift tubes. The idea is that the particle drifts free of electric fields through these tubes at constant velocity and emerges from the end of a tube just in time for the alternating voltage to have changed polarity. The largest linac in the world, at Stanford University in the USA, is 3.2 km long.

At the end of each drift tube the charged particle is accelerated by the voltage across the gap.

- The work done on the charged particle, $W = VQ$
- Where V = voltage across gap, Q = charge on particle being accelerated.
- The particle gains VQ of energy at each gap
- This work done causes the particle to accelerate
- So the E_k increases by VQ at each gap.
- The speed increases as it moves along the linear accelerator.

The length of successive drift tubes increases. This is because the speed of the charged particle is increasing and to ensure that the time taken to pass through each tube is the same, the length of the tubes must be increased. The time to pass through each drift tube is set by the frequency of the alternating voltage.

It would appear that longer linear accelerators, if they were to be built, could produce particles with yet higher speeds and energy. However special relativity sets limits on the speeds that can be achieved. At speeds comparable with the speed of light (relativistic speeds), the mass of a particle increases significantly and consequently much more energy is needed to accelerate the particle.

Linear accelerators work well but they are expensive and need a lot of space. An alternative is to use a circular accelerator.

Circular accelerators

The first circular accelerator was the cyclotron which was developed by the American physicist Ernest O. Lawrence who won the 1939 Nobel Prize in physics for his work on accelerators. The cyclotron is a bit like a linac wrapped into a tight spiral. Instead of the many tubes and accelerating gaps in the linac, the cyclotron has only two hollow evacuated chambers and a single accelerating gap. The hollow chambers are called dees (because they are shaped like two capital letter Ds back to back). A magnetic field, produced by a powerful electromagnet, is arranged perpendicular to the plane of the dees.

The voltage across the gap must be alternating so that the charged particle is always accelerated across the gap to the opposite dee.

The magnetic force acting on the charged particle is always directed towards the centre of the circular accelerator. It is this magnetic force that makes the charged particles move in a circular manner.

The direction of the magnetic field and the force applied to the moving charged particle can be found using the right-hand rule, see Figure 2.11. Remember the right-hand rule works for electrons which are negatively charged particles. If the moving charged particles are positive you'll need to reverse the direction of the variable you are finding, eg force or magnetic field.

Figure 2.13: A cyclotron

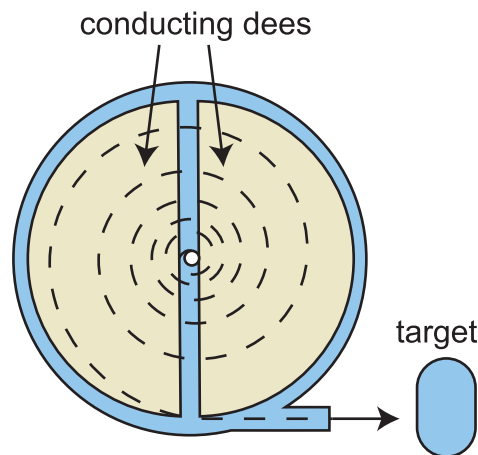

A large high frequency alternating voltage, supplied by an oscillator, is applied across the dees. Each time the charged particles pass through the gap between the dees, they are accelerated by the voltage. As the particles gain energy, they spiral out toward the edge of the accelerator until they gain enough energy to exit the accelerator.

Cyclotrons are also used in the treatment of cancers. They are capable of producing beams of protons that can be used to destroy cancer cells without doing as much damage to healthy tissue.

The synchrotron is a more powerful and more advanced design of circular accelerator. The largest and most powerful synchrotrons in the world are at the Conseil Européen de Recherches Nucleaires (CERN) near Geneva in Switzerland and at Fermi National Accelerator Laboratory (Fermilab) near Chicago, USA.

The synchrotron is a step up from the cyclotron in design. It is sometimes referred to as a synchro-cyclotron. A synchrotron consists of a tube in the shape of a large ring through which the particles travel.

Figure 2.14: A synchrotron

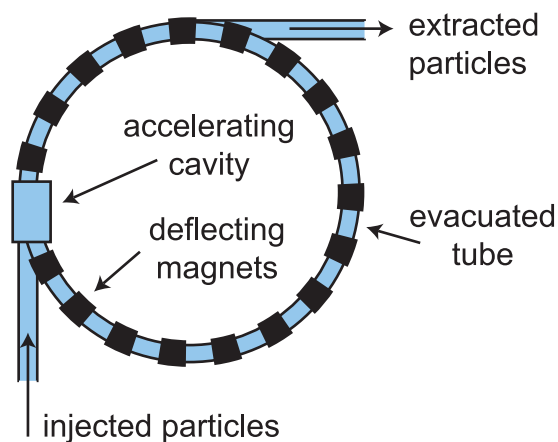

The evacuated tube is surrounded by magnets that keep the particles moving through the centre of the tube. The particles enter the tube after already having been accelerated (usually by a linac). The particles enter acceleration cavities driven by a high frequency oscillator at various points on the ring as they travel around the accelerator. In order to keep the particles moving in a fixed orbit,

the strengths of the magnetic induction of magnets surrounding the ring is increased as the particles gain energy. Computers are used to ensure that the size of the magnetic induction is adjusted so that it is synchronised with the energy of the accelerated particles and takes account of the relativistic increase in the mass of the particles (hence the name synchrotron). The particles can be steered out of their orbit using magnets and directed towards a target.

The synchrotron can be used to accelerate either protons or electrons. Most of the large machines are proton-synchrotrons. At CERN, a synchrotron allows for collisions between particles travelling in opposite directions around its ring. The energy associated with colliding beams is much greater than that involving a stationary target. The collision process is also more efficient. Stationary targets recoil and so some of the particle energy is dissipated by the movement of the target.



Particle accelerators: Questions (10 min)

Useful data:

fundamental charge e	$1.60 \times 10^{-19} \text{ C}$
mass of electron	$9.11 \times 10^{-31} \text{ kg}$
mass of proton	$1.67 \times 10^{-27} \text{ kg}$

Q15: A cyclotron is used to accelerate particles which have a charge of $-2e$ on them. The voltage across the dees is 4.00 kV . The diagram below shows the two dees and the path which the charged particles follow.

Beam of negatively charged high-energy particles

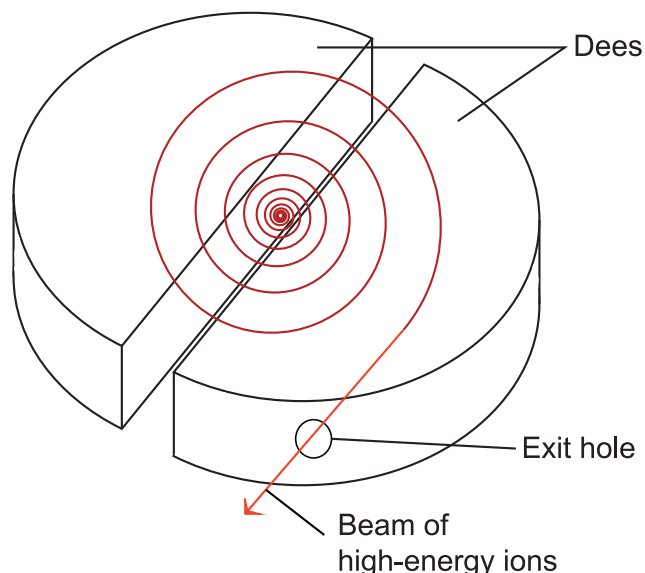

Which of the following statements is/are true?

- The right-hand dee is always positive.
- The energy gained by the charged particle each time it cross the gap is $1.28 \times 10^{-15} \text{ J}$.
- The direction of the magnetic field is down, towards the bottom of the screen/page.

- a) (i) only
 - b) (ii) only
 - c) (iii) only
 - d) (i) and (ii) only
 - e) (ii) and (iii) only
-

Q16: Fixed target and colliding beams are used in experiments to investigate fundamental particles.

Which of the following are advantages of the colliding beam method?

- i. The energy associated with colliding beams is much greater than that involving a stationary target.
 - ii. The collision process is more efficient because stationary targets recoil and so some of the particle energy is dissipated by the movement of the target.
 - iii. The accelerator moves the particles in a circular path and so takes up less space.
- a) (ii) only
 - b) (i) and (ii) only
 - c) (ii) and (iii) only
 - d) (i) and (iii) only
 - e) (i), (ii) and (iii)
-

Q17: Which of the following is *not* a type of particle accelerator?

- a) cathode ray tube
 - b) cyclotron
 - c) linac
 - d) oscillator
 - e) synchrotron
-

Q18: Which of the following factors influence(s) the frequency of rotation of a charged particle in a cyclotron?

- i. the charge on the particle
 - ii. the magnitude of the magnetic field
 - iii. the radius of the path of the particle
- a) (i) only
 - b) (ii) only
 - c) (iii) only
 - d) (i) and (ii) only
 - e) (i) and (iii) only

2.4 Summary

Summary

You should now be able to:

- describe what is meant by an electric field;
- use field lines to describe electric fields;
- explain that work is done when a charge is moved in an electric field;
- explain what is meant by potential difference;
- carry out calculations using the relationship between work done in joules, charge in coulombs and potential difference in volts;
- explain the motion of charged particles in electric fields;
- state the condition necessary for a magnetic force to exist between two charged particles;
- describe the magnetic force by using a field description;
- recognise the magnetic field patterns caused by current in a long straight wire, a flat circular coil and a long solenoid;
- describe the operation of different types of particle accelerators.

2.5 Extended information

Top tip

Links

The authors do not maintain these web links and no guarantee can be given as to their effectiveness at a particular date.

They should serve as an insight into the wealth of information available online and encourage you to explore the subject further.

- YouTube: Nice video showing the advantage of electrostatic painting.
<http://www.youtube.com/watch?v=zTwkJBtCcBA>
- LON-CAPA: Interactivity which enables you to construct baryons and mesons from quarks.
<http://www.lon-capa.org/~mmp/applist/q/q.htm>
- Boston University: Excellent simulation showing the energy increasing in a cyclotron.
http://physics.bu.edu/~duffy/semester2/c13_cyclotron.html
<http://www.youtube.com/watch?v=qQNpucos9wc>

Top tip continued

- YouTube: Video explaining the acceleration of protons in the large hadron collider at CERN.
<http://www.youtube.com/watch?v=qQNpucos9wc>

2.6 Assessment

End of topic 2 test

Go online



The following test contains questions covering the work from this topic.



The following data should be used when required:

Mass of an electron m_e	$9.11 \times 10^{-31} \text{ kg}$
Magnitude of the charge on an electron e	$1.60 \times 10^{-19} \text{ C}$

Q19: Calculate the work done, in J, in moving 20.1C of charge between two metal plates if the potential difference between the plates is 70.2 V.

.....

Q20: 12 J of work is done in moving 4.5C of charge between two points. Calculate the potential difference, in V, between the two points.

.....

Q21: A charged sphere is moved in an electric field set up between two parallel metal plates. The potential difference between the plates is 5000 V.

$3.2 \times 10^{-14} \text{ J}$ of work are used up in moving the sphere from the positive to the negative plate.

- How many excess charges (protons or electrons) are there on the sphere?
- Are these excess charges carried by electrons or protons?

.....

Q22: In a cathode ray tube, electrons are given off from the heated cathode. They are accelerated through a potential difference of 60V between the cathode and the anode. Calculate the velocity of an electron when it arrives at the anode, in m s^{-1} . Assume the initial velocity of an electron is zero.

.....

Q23: A charge of 20C gains 80J of energy in moving between two metal plates. What is the potential difference between the plates, in V?

.....

Q24: How many joules of energy are used up when a charge of 8.3mC is moved against a potential difference of 400V?

.....

Q25: A polystyrene sphere carries 310 excess charges (protons or electrons). It is placed in the electric field created by applying a potential difference between two parallel metal plates. The sphere gains 2.31×10^{-13} J of energy in moving to the negative plate.

- Calculate the potential difference between the plates, in V.
- Are the excess charges carried by electrons or protons?

.....

Q26: Electrons given off from a heated cathode in a cathode ray tube have a velocity of 2.3×10^6 m s⁻¹ when they arrive at the anode.

Calculate the potential difference between the cathode and the anode, in V.

.....

Q27: Select the correct words for the following paragraph concerning fields.

A current through a straight wire produces a {circular/linear} magnetic field.

The direction of the force exerted on moving electrons due to a magnetic field can be predicted using {right/left} hand rule.

.....

Q28: Select the correct words for the following paragraph concerning particle accelerators.

Cathode ray tubes use electrical fields to accelerate {protons/electrons} to high velocities. CRO tubes are very simple forms of linear accelerator. The longest linear accelerator is {2.3/3.2} km long. Circular accelerators such as the cyclotron and synchrotron can produce {higher/lower} energy collisions than linear accelerators. In synchrotron accelerators beam of particles travelling in the {same/opposite} directions are allowed to collide.

Topic 3

Nuclear reactions

Contents

3.1 Radioactivity	52
3.2 Decay processes	53
3.3 Nuclear energy	58
3.3.1 Fission	59
3.3.2 Fusion	59
3.3.3 Mass-Energy equivalence	61
3.3.4 Energy calculations	62
3.3.5 Summary	66
3.4 Extended information	67
3.5 Assessment	67

Learning objective

By the end of this topic you should be able to:

- explain what is meant by alpha, beta and gamma decay of radionuclides;
 - identify the processes occurring in nuclear reactions written in symbolic form;
 - describe what happens during fission and fusion reactions;
 - explain that fission may be spontaneous or induced by neutron bombardment;
 - explain why fission and fusion reactions produce energy and to carry out calculations using $E = mc^2$;
 - Discuss coolant and containment issues in nuclear fusion reactors.
-

In this topic we will examine nuclear physics.

The topic starts with an explanation of basic terms in nuclear physics including the simplest forms of nuclear reactions and decays.

The processes of fission and fusion will then be discussed along with how large amount of energy can be derived from these reactions.

The unit also examines some of the developments in fusion reactors.

3.1 Radioactivity

We now know that atoms actually consist of protons, neutrons and electrons. The protons and neutrons are found inside the nucleus, and the electrons orbit around the outside.

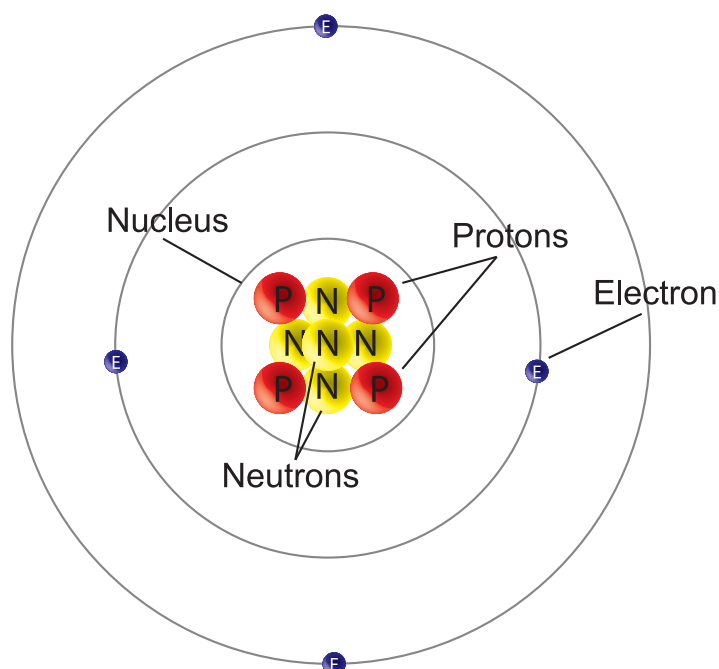

A labeled representation of the atom.

The number of protons in an atom determines the element. For example, uranium has 92 protons, iron has 26 protons, etc. This is known as the **atomic number** (Z) of the element.

We use the term **nucleon** to refer to both protons and neutrons, and the total number of nucleons in an atom is known as the **mass number** (A). Although the atomic number is fixed for a particular element, the mass number is not. This is because elements can contain different numbers of neutrons. For example, one form of carbon contains 6 neutrons, and another has 8 neutrons; their mass numbers are 12 and 14 respectively (carbon always contains 6 protons). The different forms of an element are known as **isotopes**, and the nucleus of a particular isotope is called a **nuclide**. The terms **radioisotope** and **radionuclide** are used to refer to radioactive forms of an element. To refer to a particular isotope we must give its mass number e.g. carbon-12 or carbon-14.

We use the symbol A_ZX to show the atomic and mass numbers for any particular nuclide (X), where X stands for the chemical symbol as found in the periodic table of elements. The 2 nuclides of carbon given above would be written as: ${}^{12}_6\text{C}$ and ${}^{14}_6\text{C}$.

Notice that we can calculate the number of neutrons in a nuclide by subtracting the atomic number from the mass number ($A - Z$).

Example : Neutrons in a nuclide

Calculate the number of neutrons in uranium-238.

Answer:

Using a periodic table we find that uranium has the chemical symbol U and contains 92 protons, which means that U-238 has the symbol ${}_{92}^{238}\text{U}$.

We can now calculate the number of neutrons.

$$\text{Mass number (A)} = 238$$

$$\text{Atomic number (Z)} = 92$$

$$A - Z = 238 - 92$$

$$\therefore \text{Number of neutrons} = 146$$

3.2 Decay processes

Some isotopes of elements are unstable and are said to be radioactive. This means that they give off particles or **electromagnetic waves**. In doing so these radionuclides change into a more stable form of the element, or indeed into a completely different element. The original nuclide is called the parent, and the new nuclide is called the daughter. There are 3 possible processes involved in radioactive decay, known as alpha (α), beta (β) and gamma (γ) decay. We will look at each of these in more detail.

Alpha (α) decay

An α particle consists of 2 protons and 2 neutrons; i.e. it is a helium nucleus, ${}^4_2\text{He}$. Since they have no electrons, α particles have a double positive charge, which means that they are highly ionising and can pull electrons from nearby atoms. Alpha particles are the most massive of the 3 types of radiation, and are more likely to collide with other nuclei. This causes them to lose kinetic energy, which explains why they are easily absorbed by relatively thin materials, such as a sheet of paper. When an element releases an alpha particle a new element is formed, as we can see by looking at the following example:

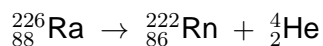

Notice that the *total* number of each type of nucleon remains the same after the reaction: 88 protons and 138 neutrons.

Beta (β) decay

Beta particles are fast moving electrons, ${}^0_{-1}\text{e}$, and as they carry only a single negative charge, they are not as ionising as alpha particles. They are however more penetrating due to their extremely small size. They can be stopped by a few millimetres of metal, such as aluminium. Beta production is not as simple as it may seem however, since the electron comes from the nucleus of the atom!

During beta decay, a neutron in the nucleus splits apart to form a proton and an electron. The proton remains in the nucleus, but the electron (β particle) is thrown out at high speed. As with alpha decay, a new element is formed:

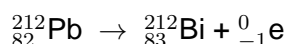

Although the total number of nucleons is the same before and after (212), there is one more proton (82 \rightarrow 83) and one less neutron (130 \rightarrow 129).

Students who have already studied the section on the standard model will be aware that beta decay is in fact more complex than the account given above. However, when thinking about decay series and equations this explanation is adequate.

Gamma (γ) decay

Gamma decay is different from both alpha and beta decay in that the nucleus does not change its structure. This is due to the fact that gamma rays are electromagnetic waves, rather than particles. Gamma rays are usually given out by a nucleus after alpha or beta decay, in order to lose excess energy. As gamma rays have zero mass and carry no charge they are much more penetrating than either alpha or beta particles, but they produce relatively few ions. Gamma rays have the symbol ${}^0_0\gamma$.

Identify the radiation

Go online



The apparatus shown is used to determine what type of radiation(s) is/are given off by an unknown source.

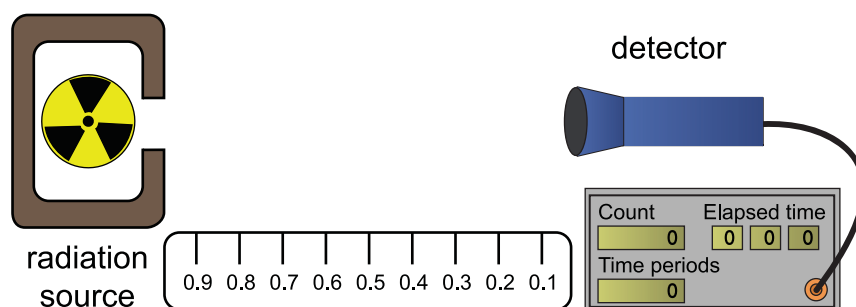

The background activity is measured (over a period of, say 10 seconds) before the source is introduced. This allows us to know the natural level of radioactivity in the room.

The source is now introduced and the activity is measured again over the same time period.

We are now ready to test to find out which type(s) of radiation the source is emitting.

Firstly a sheet of paper is placed in front of the detector. This will absorb alpha particles. The count is again measured over the same time interval as before. If the count is unaffected then the source is not emitting alpha particles, if the count drops to the background radiation level

then the source is emitting only alpha particles, however if the count is somewhere between these two values the source is emitting a mixture of alpha particles and another radiation.

Now the sheet of paper is removed and replaced by a thin sheet of aluminium. The aluminium will block both alpha and beta particles. We can use this to determine if the source emits beta particles and using the same process as alpha particles determine if this source only emits beta particles or a mixture of beta particles and another form of radiation.

Finally the aluminium is replaced by a sheet of lead. Lead will block both alpha and beta particles and will **reduce** the count for gamma radiation. It is important to realise that the lead does not completely block gamma radiation but reduces its effect. When the activity is now measured the count for a gamma only source will not drop to the background count but will be significantly reduced. Thus if aluminium has no affect on a source's count but lead reduces it the source is a gamma source.

By using the three different absorbers it is possible to deduce which radiation(s) is/are emitted by a radioactive source.

Decay Equations

We can use our knowledge of radioactive decay to identify unknown nuclides or particles in nuclear processes.

Examples

1. Unknown particle

Identify the particles released at each stage in the following decay series.

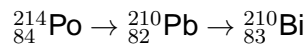

Answer:

We will call the unknown emitted particles X and Y. By looking at the changes in the atomic and mass numbers of the nuclei at each stage, we can calculate the atomic number and mass number of the emitted particles, as shown in Equation 3.1.

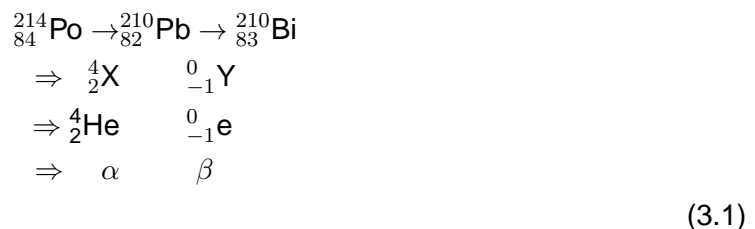

X must be a helium nucleus, and Y must be an electron, so X is an alpha particle and Y is a beta particle.

.....

2. Unknown Daughter

Identify the element formed when carbon-14 undergoes beta decay.

Answer:

We first write out the nuclear equation, using the symbol A_ZX to represent the unknown nucleus, as shown in Equation 3.2.

$$\begin{aligned}
 {}^{14}_6\text{C} &\rightarrow {}^A_ZX + {}^0_{-1}\text{e} \\
 14 &= A + 0 \\
 A &= 14 \\
 6 &= Z + (-1) \\
 Z &= 7 \\
 \text{Atomic number } 7 &= \text{nitrogen} \\
 \text{Nuclear symbol} &= {}^{14}_7\text{N}
 \end{aligned}
 \tag{3.2}$$

We can then form equations to find the mass number (A) and the atomic number (Z) of X. By using a periodic table of elements, we find that X is the isotope nitrogen-14.

.....

3. Unknown Parent

Which nuclide produces radon-222 by alpha emission?

Answer:

This is very similar to the previous problem and we use the same method to solve it. Again we use the symbol A_ZX , but this time it refers to the unknown parent nucleus, see Equation 3.3.

$$\begin{aligned}
 {}^A_ZX &\rightarrow {}^{222}_{86}\text{Rn} + {}^4_2\text{He} \\
 A &= 222 + 4 \\
 A &= 226 \\
 Z &= 86 + 2 \\
 Z &= 88 \\
 \text{Atomic number } 88 &= \text{radium} \\
 \text{Nuclear symbol} &= {}^{226}_{88}\text{Ra}
 \end{aligned}
 \tag{3.3}$$

We then form equations for A and Z and solve them to find the unknown isotope, in this case radium-226.

It is important to remember that gamma decay will not show up in a decay equation, as it does not result in a new daughter product.

The decay of radium to radon, shown in the last example, is only part of a longer chain of decays as radioactive uranium-238 changes into a stable isotope of lead. This is known as a **radioactive decay series**, see Figure 3.1.

Figure 3.1: Radioactive decay series

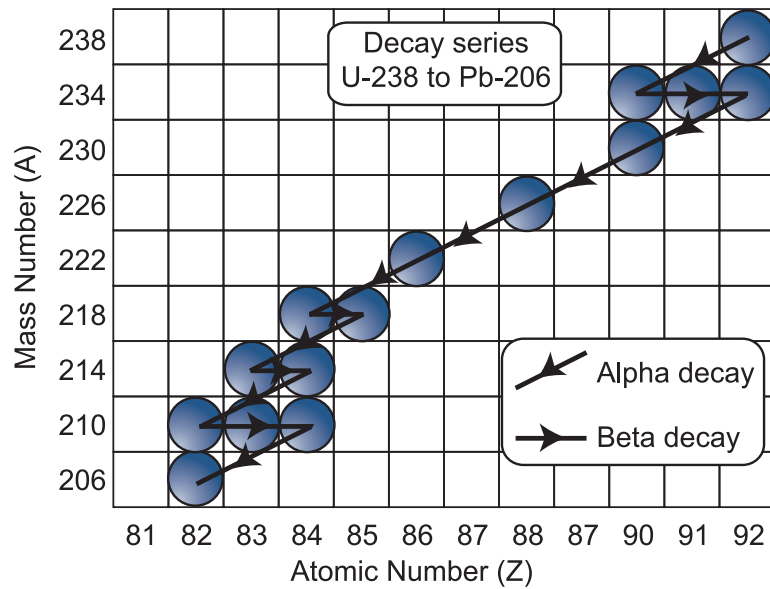

Radioactive decay: Questions

Go online



Q1: Which of the following radioactive decay mechanisms involve(s) the release of a particle from the nucleus of the atom?

- i. alpha
 - ii. beta
 - iii. gamma
- a) (i) only
 - b) (ii) only
 - c) (i) and (ii) only
 - d) (i) and (iii) only
 - e) (i), (ii) and (iii)

.....

Q2: Which one of the following statements is *false*?

- a) Alpha particles are more massive than beta particles.
- b) A new element is always formed after radioactive decay.
- c) Alpha particles can be stopped by aluminium.
- d) Gamma rays are more penetrating than beta particles.
- e) A beta particle is a fast moving electron.

.....

Q3: Which of the following statements is/are true about beta decay?

- i. The daughter nuclide has 1 more proton than the parent nuclide.
- ii. Beta decay results in a different isotope of the parent.
- iii. Beta decay is the result of a proton splitting into a neutron and electron.

- a) (i) only
 - b) (ii) only
 - c) (iii) only
 - d) (i) and (ii) only
 - e) (i) and (iii) only
-

Q4: What is ejected when uranium-234 changes to thorium-230?

- a) alpha particle
 - b) beta particle
 - c) gamma ray
 - d) proton
 - e) neutron
-

Q5: Which one of the following decay equations correctly shows beta decay followed by alpha decay?

- a) ${}_{91}^{234}\text{Pa} \rightarrow {}_{89}^{230}\text{Ac} \rightarrow {}_{90}^{230}\text{Th}$
- b) ${}_{91}^{234}\text{Pa} \rightarrow {}_{92}^{234}\text{U} \rightarrow {}_{90}^{230}\text{Th}$
- c) ${}_{90}^{234}\text{Th} \rightarrow {}_{91}^{234}\text{Pa} \rightarrow {}_{92}^{234}\text{U}$
- d) ${}_{90}^{230}\text{Th} \rightarrow {}_{88}^{226}\text{Ra} \rightarrow {}_{86}^{222}\text{Rn}$
- e) ${}_{91}^{234}\text{Pa} \rightarrow {}_{92}^{234}\text{U} \rightarrow {}_{92}^{234}\text{U}$

3.3 Nuclear energy

There are two main types of nuclear reactions that can produce energy - fission and fusion.

In this section you will study the difference between these two types of nuclear reactions.

You will also study the difference between spontaneous and induced nuclear fission.

Finally you will study why these reactions can result in the release of large amounts of energy.

You must take care to spell **fission** and **fusion** correctly. Because the words are so similar it is easy to miss out an "s" or replace a "u" by an "i", so take care.

3.3.1 Fission

Fission is the process of splitting a large nucleus into two or more smaller nuclei. It is important to note that it is the nucleus which is split. When describing fission (or fusion) always refer to the nucleus (or plural, nuclei) **not** the atom. This process can happen for no apparent reason, in which case it is called **spontaneous fission**.

An example of spontaneous nuclear fission is shown below.

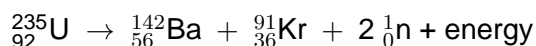

It is more likely to happen if the nucleus is hit by a neutron, in which case the process is known as **induced fission**. This is the basis for the generation of nuclear power and the nuclear bomb. One possible fission of uranium-235 is shown.



Check for yourself that the mass (A) and atomic (Z) numbers are conserved in these reactions. In the second equation you must remember that there are 3 neutrons produced so they contribute 3 to the total mass number on the right hand side of the second equation.

We will see in a later section why energy is released and how to calculate the amount of energy.

Energy is released during fission, and although the splitting of a single nucleus provides only a tiny quantity of energy, the process produces more neutrons, as can be seen above. These extra neutrons can go on to cause other fissions in the surrounding nuclei. This is known as a **chain reaction**, and since there are billions of nuclei in even a small mass of nuclear fuel, vast amounts of energy can be released. In a nuclear bomb the chain reaction is allowed to progress in an uncontrolled manner, but in a nuclear power station the chain reaction is carefully controlled to provide a steady flow of energy. This is done by absorbing some of the neutrons before they split other nuclei.

3.3.2 Fusion

Fusion is the nuclear process that powers the Sun and all the stars. It is also used in hydrogen bombs, which are about one hundred times more powerful than fission bombs. During fusion, 2 light nuclei are joined (fused) together to make a heavy nucleus. Fusion reactions are difficult to start, requiring extremely high temperatures (up to 100 million degrees Celsius), to overcome the natural repulsion of the positive nuclei. They are even more difficult to control, but they do have certain advantages over fission reactions: there is a plentiful supply of the fuel, and the waste products are much less dangerous than the waste products from fission reactions.

Although a single fusion releases less energy than a single fission, there is a greater **energy yield** per kilogram of fuel. The nuclei used in fusion are much smaller than those used in fission, and so there are many more nuclei in each kilogram. One possible fusion reaction uses 2 isotopes of hydrogen (deuterium and tritium) to produce an alpha particle and a neutron.

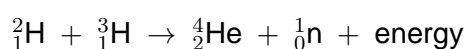

Deuterium (${}_1^2\text{H}$) is found in ordinary water, and although tritium (${}_1^3\text{H}$) is much less abundant, it can be made from lithium, of which there is a plentiful supply.

The process is almost impossible to control because of the high temperatures that have to be maintained in the nuclear reactor. Experiments are ongoing to contain the reaction inside a magnetic

field. This is not a problem for nuclear weapons, since the energy is not intended to be contained. The high temperature needed to start the fusion reaction in a hydrogen bomb is provided by the detonation of a fission bomb.

The Joint European Torus (JET) in the UK has produced 16 megawatts of power in a laboratory from a fusion reaction. It has also shown advances in being able to control the high temperature plasma. A much larger 500 megawatt fusion heat plant is currently under construction in France. This power plant known as ITER will use a tokamak magnetic containment system. This type of system uses electromagnets to force the plasma to form a torus shape. A torus has a similar shape to a donut. The fusion materials can then be forced to form a current around the torus.

The fusion reactions produce large numbers of fast moving neutrons. These neutrons are electrically neutral and so are not contained by the magnetic field. It is the energy that these neutrons are carrying that is extracted from the reactor in the form of heat.

The inside walls of the tokamak must be cooled as the neutrons are carrying such large quantities of energy that they could cause the walls of the reactor to melt.

The diagram below shows the design of a tokamak fusion reactor. The plasma has many charged particles and neutrons in it. The magnetic fields keep these charged particles in the plasma within the vacuum vessel. Remember from earlier work that moving charged particles experience a force when they move within a magnetic field.

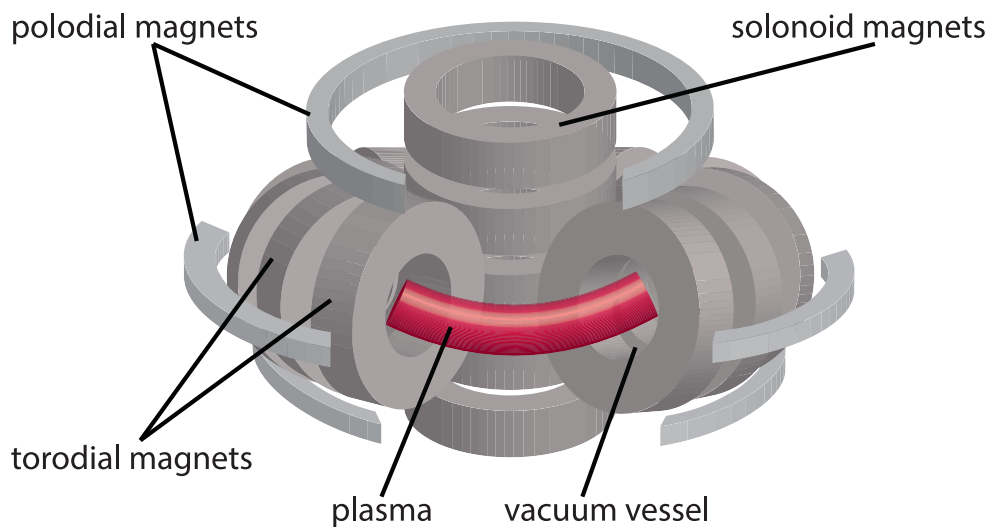

The neutrons, which are not charged, would pass through the magnetic field and hit the walls of the vacuum vessel. The neutrons carry so much energy that the walls would need to be cooled. It is this heat energy that could be used to generate electrical energy.

Construction of one of these huge fusion reactors is currently underway in France but we do not yet have working fusion reactors. There are many problems to be overcome before a fusion reactor will be operational. A fusion reactor will require a huge amount of energy to produce the very high temperatures required to produce the plasma and the very strong magnetic fields required to confine (trap) the plasma. In addition the walls of the vacuum vessel will need to be able to withstand very high temperatures.

A fusion reactor has two major advantages over the fission reactors which are currently in use. Firstly they use hydrogen of which there is a huge supply in the sea. Secondly they produce very little radioactive waste.

3.3.3 Mass-Energy equivalence

Why do fission and fusion reactions release kinetic energy? To understand the answer to this question, we need to introduce a new concept: mass-energy equivalence. What this means is that mass and energy are essentially the same thing, and so mass could be measured in joules, or energy could be measured in kilograms. The two quantities are linked by the famous equation from Albert Einstein: $E = m c^2$, where E is the energy in J; m is the mass in kg; and c is the speed of light in a vacuum ($3 \times 10^8 \text{ m s}^{-1}$).

Using the above equation, we can show that 1 kg of matter is equivalent to 9×10^{16} J of energy, which is roughly the energy we would get by burning 15 million tonnes of coal. Fission and fusion work by changing a small fraction of the mass of the fuel into energy. We will look at this in more detail.

If we look back at the fission reaction we met earlier, we can see that the atomic and mass numbers are the same on each side of the reaction: $A = 236$; $Z = 92$ (remember to add in the neutrons).

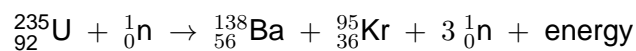

However, if we look at the actual total mass of each of the fission products, we find that it is less than the original total mass of the uranium nucleus and neutron.

The total mass before the fission reaction

- mass of uranium nucleus + mass of one neutron

is slightly greater than total mass after the fission reaction

- mass of barium nucleus + mass of krypton + mass of 3 neutrons

The mass lost (not the mass defect) is converted into energy. The energy produced can be calculated using $E=mc^2$, where m is the mass lost in one fission reaction.

The same is also true in a fusion reaction.



The total mass before the fusion reaction

- mass of deuterium nucleus + mass of tritium nucleus

is slightly greater than the total mass after the fusion reaction

- mass of helium nucleus + mass of one neutron

The mass lost (not the mass defect) is converted into energy. The energy produced can be calculated using $E=mc^2$, where m is the mass lost in one fission reaction.

3.3.3.1 Mass-energy equivalence, for interest only

The explanation of this mass lost is given below. If we look at the actual total mass of the uranium nucleus and neutron we find that it is greater than the total mass of the fission products



This is due to the difference in the **binding energy** of the nuclei. Every nucleus has slightly less mass than the same number of individual nucleons. For example an alpha particle has a mass of 4.003 u (1 atomic mass unit (u) = 1.66×10^{-27} kg), but the mass of 2 protons and 2 neutrons add up to 4.034 u. This **mass defect**, as it is known, is equivalent to the binding energy of the nucleus.

In the above example the barium and krypton nuclei are more stable than the original uranium nucleus, which means that the nucleons are more tightly bound together. This results in some of the mass of the uranium being turned into energy.

Elements that have neither high nor low mass numbers such as iron (${}_{26}^{56}\text{Fe}$) are the most stable, while elements above and below this are less so. We can see this in a graph of binding energy against atomic mass, see Figure 3.2. Fission works by taking a large, unstable nucleus and changing it into 2 smaller, more stable nuclei.

Figure 3.2: Binding energy curve

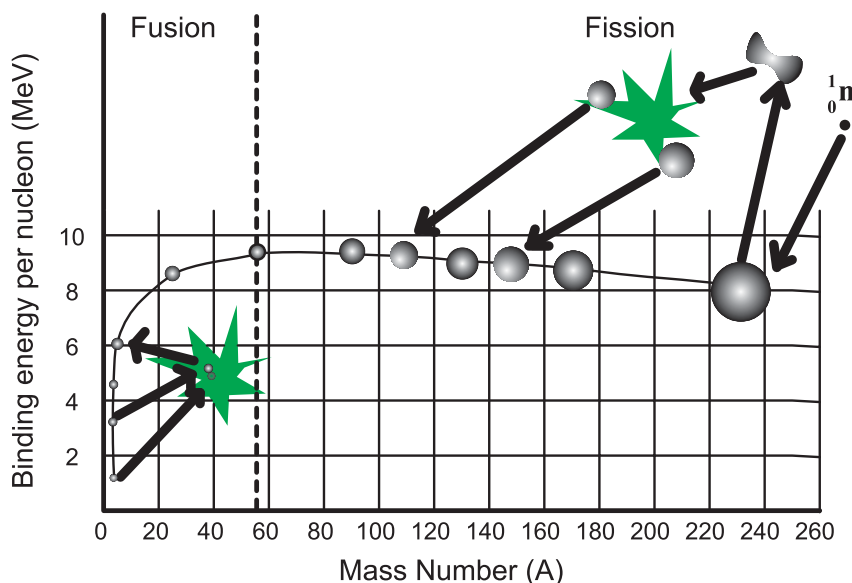

You can also see from the binding energy curve that fusion reactions will also result in a more stable nucleus. Although fusion results in a larger nucleus, it has slightly less mass than the combined mass of the original nuclei, and so again energy is released.

3.3.4 Energy calculations

As mentioned in the previous section, the amount of energy released in a fission or fusion reaction can be calculated using Einstein's equation: $E = m c^2$. The method is the same for both reactions, but we will work through an example of each.

Step 1: Check that the atomic and mass numbers are the same on each side of the reaction (If these numbers do not add up check if the number of neutrons and/or beta particles after the reaction is correct. If it is not alter it so that the equation balances).

Step 2: Find the actual total mass before the reaction (from a table of atomic masses, Table 3.1).

Step 3: Find the actual total mass after the reaction.

Step 4: Find the 'lost' mass (convert to kilograms if necessary).

Step 5: Use the equation $E = mc^2$ to calculate the energy released.

when carrying out this type of calculation, work through the calculation with many more significant figures than usual. In the final line of your calculation round your answer to the usual 3 significant figures. If you round off too early, your final answer will be not correct.

Table 3.1: Table of Atomic masses

Particle	${}_{92}^{235}\text{U}$	${}_{54}^{136}\text{Xe}$	${}_{42}^{98}\text{Mo}$	${}_0^1\text{n}$
mass ($\times 10^{-27}$ kg)	390.173	225.606	162.522	1.675

Examples

1. Fission reaction

Identify particle X and calculate the energy released in the reaction shown:



Answer:

Step 1

Lets look at the mass and atomic numbers on each side of the reaction:

$$\text{mass numbers: } 235 + 1 = 136 + 98 + (2 \times 1) + 4A$$

$$236 = 236 + 4A$$

$$4A = 236 - 236$$

$$4A = 0$$

$$A = 0$$

$$\text{atomic numbers: } 92 + 0 = 54 + 42 + (2 \times 0) + 4Z$$

$$92 = 96 + 4Z$$

$$4Z = 92 - 96$$

$$4Z = -4$$

$$Z = -1$$

In order to balance the equations, the 4 unknown particles (X) must each have mass number 0 and atomic number -1, so X must be a beta particle. The reaction then becomes:

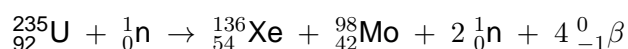

Since the mass of the four beta particles is less than 0.01% of the mass of one neutron, we can ignore them in the energy calculation.

Step 2

Use the table of atomic masses to calculate the total mass before the reaction:

$$\text{mass of } {}_{92}^{235}\text{U} = 390.173 \times 10^{-27} \text{ kg}$$

$$\text{mass of } {}_0^1\text{n} = 1.675 \times 10^{-27} \text{ kg}$$

$$\text{total mass} = 391.848 \times 10^{-27} \text{ kg}$$

Step 3

Use the table of atomic masses to calculate the total mass after the reaction:

$$\text{mass of } {}_{54}^{136}\text{Xe} = 225.606 \times 10^{-27} \text{ kg}$$

$$\text{mass of } {}_{42}^{98}\text{Mo} = 162.522 \times 10^{-27} \text{ kg}$$

$$\text{mass of } 2{}_0^1\text{n} = 3.35 \times 10^{-27} \text{ kg}$$

$$\text{total mass} = 391.478 \times 10^{-27} \text{ kg}$$

Remember that we have ignored the mass of the beta particles, since it is insignificant compared to the total mass.

Step 4

Find the lost mass:

$$\text{total mass before} = 391.848 \times 10^{-27} \text{ kg}$$

$$\text{total mass after} = 391.478 \times 10^{-27} \text{ kg}$$

$$\text{lost mass} = 0.370 \times 10^{-27} \text{ kg}$$

Step 5

Calculate the energy released:

$$\begin{aligned} E &= m c^2 \\ &= 0.370 \times 10^{-27} \times (3 \times 10^8)^2 \\ &= 3.3 \times 10^{-11} \text{ J} \end{aligned}$$

.....

2. Fusion reaction

Calculate the energy released in the reaction shown:

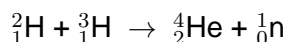

Answer:

The steps are the same as in the fission reaction, so we will not show them individually.

The equation is balanced, since the totals of the atomic numbers and the mass numbers are the same on both sides.

Particle	${}_1^2\text{H}$	${}_1^3\text{H}$	${}_2^4\text{He}$	${}_0^1\text{n}$
mass (u)	2.014	3.016	4.003	1.009

$$1 \text{ u} = 1.66 \times 10^{-27} \text{ kg}$$

Note that the masses are given in **Atomic mass units (u)**.

$$\begin{aligned}\text{initial mass} &= 2.014 \text{ u} + 3.016 \text{ u} \\ &= 5.030 \text{ u}\end{aligned}$$

$$\begin{aligned}\text{final mass} &= 4.003 \text{ u} + 1.009 \text{ u} \\ &= 5.012 \text{ u}\end{aligned}$$

$$\begin{aligned}\text{lost mass} &= 5.030 \text{ u} - 5.012 \text{ u} \\ &= 0.018 \text{ u} \\ &= 0.018 \times (1.66 \times 10^{-27}) \text{ kg} \\ &= 2.988 \times 10^{-29} \text{ kg}\end{aligned}$$

$$\begin{aligned}E &= m c^2 \\ &= 2.988 \times 10^{-29} \times (3 \times 10^8)^2 \\ &= 2.689 \times 10^{-12} \text{ J}\end{aligned}$$

Mass-energy equivalence: Questions

Go online



You will find the data you need for this activity in the table of atomic masses below.

nuclide/ particle	${}^1_1\text{H}$	${}^2_1\text{H}$	${}^3_2\text{He}$	${}^1_0\text{n}$	${}^4_2\text{He}$
atomic mass ($\times 10^{-27}$ kg)	1.673	3.343	5.007	1.675	6.645
nuclide/ particle	${}^{235}_{92}\text{U}$	${}^{91}_{36}\text{Kr}$	${}^{142}_{56}\text{Ba}$	${}^{134}_{54}\text{Xe}$	${}^{100}_{38}\text{Sr}$
atomic mass ($\times 10^{-27}$ kg)	390.173	150.932	235.581	222.282	165.892

Speed of light $c = 3 \times 10^8 \text{ m s}^{-1}$

Q6: The following equation represents an induced fission reaction of a uranium -235 nucleus.



Using data from the above table, calculate the number of neutrons released.

- 1
- 2
- 3
- 4
- 5

.....

Q7: What is the energy released in the following fission reaction?

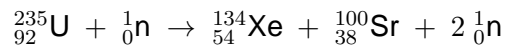

- a) $1.216 \times 10^{-10} \text{ J}$
- b) $1.799 \times 10^{-10} \text{ J}$
- c) $2.916 \times 10^{-16} \text{ J}$
- d) $2.916 \times 10^{-11} \text{ J}$
- e) $9.720 \times 10^{-20} \text{ J}$

.....

Q8: How much energy is released in the following fusion reaction?

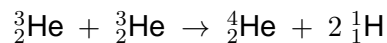

- a) $1.526 \times 10^{-10} \text{ J}$
- b) $2.070 \times 10^{-12} \text{ J}$
- c) $6.900 \times 10^{-21} \text{ J}$
- d) $5.088 \times 10^{-19} \text{ J}$
- e) $2.070 \times 10^{-15} \text{ J}$

3.3.5 Summary

Summary

You should now be able to:

- explain what is meant by alpha, beta and gamma decay of radionuclides;
- identify the processes occurring in nuclear reactions written in symbolic form;
- explain that in fission a nucleus of large mass number splits into two nuclei of smaller mass numbers, usually along with several neutrons;
- explain that in fusion two nuclei combine to form a nucleus of larger mass number;
- explain, using $E = m c^2$, how the products of fission and fusion acquire large amounts of kinetic energy;
- carry out calculations using $E = m c^2$ for fission and fusion reactions;
- describe the structure of a fusion reactor, torus;
- discuss the issues related to coolant and containment of a fusion reactor.

3.4 Extended information

Top tip

Links

The authors do not maintain these web links and no guarantee can be given as to their effectiveness at a particular date.

They should serve as an insight into the wealth of information available online and encourage you to explore the subject further.

- University of Colorado: Simulation of an induced fission reaction with the release of several neutrons. It also enables chain reactions to be simulated.
<http://phet.colorado.edu/en/simulation/nuclear-fission>
- University of Nebraska: Simulation showing the fusion reaction between several hydrogen nuclei to produce helium nuclei, gamma rays and neutrinos.
<http://astro.unl.edu/classaction/animations/sunsolarenergy/fusion01.html>
- Princeton: Operate your own tokamak fusion reaction and control the magnetic confinement etc.
<http://w3.pppl.gov/~dstotler/SSFDF/>

3.5 Assessment

End of topic 3 test

Go online



The following data should be used when required:

Speed of light c	$3.0 \times 10^8 \text{ m s}^{-1}$
1 atomic mass unit u	$1.66 \times 10^{-27} \text{ kg}$

Q9: A radioisotope has mass number 238 and atomic number 92.

- How many protons are there in the nucleus of the radioisotope?
- How many neutrons are there in the nucleus of the radioisotope?
- How many particles are there in the nucleus of the radioisotope?

.....

Q10: A radionuclide with mass number 235 and atomic number 90 decays by ejecting 3 alpha particles and 3 beta particles.

- What is the mass number of the final nuclide in this decay series?
- What is the atomic number of the final nuclide in this decay series?

.....

Q11: The atomic number of a radionuclide is reduced by 8 when it emits a number of alpha particles during part of a decay series.

- How many alpha particles did it emit?
- By how much does the mass number of the nucleus change?
- If the final daughter nuclide in this decay series emits a gamma ray, by how much does the atomic number of this nuclide change?

.....

Q12: A uranium nucleus suddenly splits apart, producing two smaller nuclei and a number of neutrons, as shown in the reaction below.

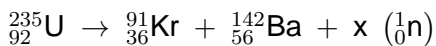

- What type of nuclear reaction is this an example of? (2 words)
- How many neutrons are released in the reaction?
- If the atomic masses of the particles are as shown in the table, how much energy, in J, is released in the reaction? Give your answer to 3 significant figures.

Particle	Atomic mass $\times 10^{-27}$ kg
uranium (U)	390.173
krypton (Kr)	150.932
barium (Ba)	235.581
neutron (n)	1.675

.....

Q13: A fusion reaction results in a loss of mass equal to 0.027u. How much energy (in J) is released in the reaction?

$$1 \text{ u} = 1.66 \times 10^{-27} \text{ kg}$$

Topic 4

Wave particle duality

Contents

4.1 Photoelectric emission	70
4.1.1 The photoelectric effect	70
4.1.2 Investigating the photoelectric effect	74
4.1.3 Wave particle duality	76
4.2 Photoelectric calculations	77
4.3 Uses of the photoelectric effect	78
4.4 Summary	80
4.5 Extended information	81
4.6 Assessment	82

Learning objective

By the end of this topic you should be able to:

- describe the photoelectric effect;
 - explain the relationship between photoelectric current and the irradiance of the incident radiation;
 - explain the relationship between photoelectric current and the frequency of the incident radiation;
 - carry out calculations using the relationship $E = hf$;
 - explain the relationship between irradiance and number of photons, $I = Nhf$;
 - state the relationship between the kinetic energy of photoelectrons, photon energy and the work function of the material, $E_k = hf - hf_0$;
 - Use the following terms correctly in context: photon, photon energy, threshold frequency, work function, photoemission of electron and photoelectric current.
-

In the late nineteenth century Heinrich Hertz was investigating how an electrical spark created in one electrical circuit could cause a spark in another, electrically-isolated, circuit. He noticed that the spark in the secondary circuit was more pronounced when it was illuminated by the light from the original spark. This seemed to suggest that light was enhancing the current in some way. He went on to investigate this photoelectric effect as it became known, little realising that it would lead to a major controversy about the nature of light.

4.1 Photoelectric emission

Learning objective

To describe the photoelectric effect.

To explain the relationship between photoelectric current and the irradiance of the incident radiation.

To explain the relationship between photoelectric current and the frequency of the incident radiation.

Photoelectric emission takes place when ultraviolet radiation is shone on to a negatively charged zinc plate. This causes electrons to be ejected from the plate until it is discharged. This effect had been observed by scientists but could not be explained. It was not until Albert Einstein turned his attention to this problem that an explanation was found.

The work that Einstein did in this area led to the foundation of quantum mechanics.

4.1.1 The photoelectric effect

The **photoelectric effect** can be demonstrated using a **gold leaf electroscope** (Figure 4.1): a simple device that can be used to measure small amounts of positive or negative charge. When charged the gold leaf will be repelled from its support and the angle between the leaf and the support is an indication of the amount of charge on the electroscope. The electroscope can be discharged by connecting the metal cap to earth, allowing charge to flow from the device.

Figure 4.1: Gold leaf electroscope

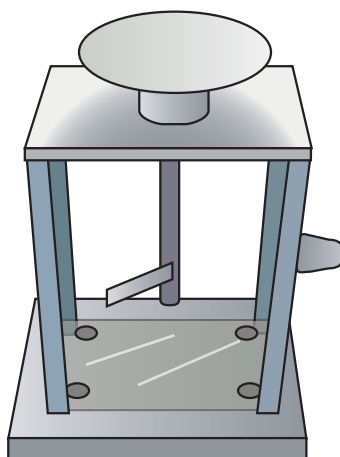

A positively or negatively charged electroscope can also be discharged by bringing a burning taper near to the cap. This is because the flame ionises the air around it. If the electroscope is positively charged the negative ions will be attracted towards it and so cause it to discharge. Similarly if the electroscope is negatively charged the positive ions will be attracted towards it and cause the electroscope to discharge.

Under certain conditions light shining on the cap of an electroscope will also cause it to discharge but only if the electroscope is negatively charged and if the light source has a high enough frequency (with most metal caps ultra violet is required to discharge a negatively charged electroscope).

We cannot explain this in terms of ionisation of the air. If the light was ionising the air a positively charged scope would be discharged as well as a negatively charged electroscope. Some other mechanism must be involved in the discharge of the negatively charged electroscope.

Photoelectric investigation (25 min)

Go online



An electroscope is charged and then illuminated using different sources of electromagnetic radiation.

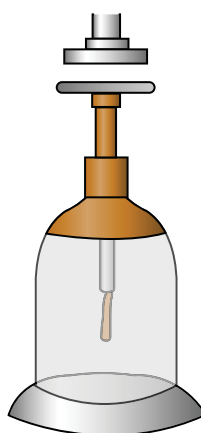

Under certain circumstances the electroscope discharges and under others it does not. Whether or not the electroscope discharges or not depends on the charge on the scope, the type of metal on the cap and on the frequency of the radiation used.

The photoelectric effect depends on the frequency and irradiance of radiation and on the type of material irradiated.

Photoelectric investigation: Questions

Go online



We can summarise the results of the previous investigation in the following table.

Light	Irradiance	Metal	Charge	Effect
Visible	Low	Steel	Positive	None
Visible	Low	Steel	Negative	None
Visible	Low	Zinc	Positive	None
Visible	Low	Zinc	Negative	None
Visible	High	Steel	Positive	None
Visible	High	Steel	Negative	None
Visible	High	Zinc	Positive	None
Visible	High	Zinc	Negative	None
Ultraviolet	Low	Steel	Positive	None
Ultraviolet	Low	Steel	Negative	None
Ultraviolet	Low	Zinc	Positive	None
Ultraviolet	Low	Zinc	Negative	Slow discharge
Ultraviolet	High	Steel	Positive	None
Ultraviolet	High	Steel	Negative	None
Ultraviolet	High	Zinc	Positive	None
Ultraviolet	High	Zinc	Negative	Fast discharge

At first sight it may seem that this is a large table that tells us very little. However, this is a case where we can tell as much from the situations that do not produce the photoelectric effect as we can from those that do.

Use the table to answer the following questions:

Q1: Can a positively charged electroscope be discharged by light?

- a) Yes
- b) No

.....

Q2: Can white light cause the photoelectric effect in zinc or steel?

- a) Yes
- b) No

.....

Q3: Can ultraviolet radiation cause the photoelectric effect in steel?

- a) Yes
- b) No

.....

Q4: Can ultraviolet radiation cause the photoelectric effect in zinc?

- a) Yes
- b) No

.....

Q5: Is the photoelectric effect dependent on the irradiance of the ultraviolet source?

- a) Yes
- b) No

The answer to the question 'Can a positively charged electroscope be discharged by light?' suggests that the photoelectric effect is caused by the removal of electrons from the metal. The answers to the other questions tell us that the effect also depends on the type of metal, the type of radiation and the irradiance of the radiation.

It was already known that electrons can escape from a metal if they are able to absorb enough energy. The fact that no effect was observed with steel suggests that the electrons are more difficult to remove but why should there be a difference between white light and ultraviolet?

Visible light is electromagnetic radiation. So too is ultraviolet although it has a higher frequency. This is where the problem arises. According to classical theory the energy of a wave is related to its amplitude and so there is no way to explain why a very dim ultraviolet source can cause the photoelectric effect while a very bright white light source cannot. Think of the electrons in the metal as pebbles on a beach and the light as the sea. Why should small amplitude waves, arriving often, throw the pebbles inland, while low frequency waves, no matter how big, are unable to remove them from the beach?

The only plausible explanation for the photoelectric effect is that light behaves like a particle and that the energy of the particle, or **photon**, is related to the frequency of the radiation. Every photon of ultraviolet radiation has enough energy to remove electrons from zinc but not enough to remove them from steel. The energy of a photon of visible light is not enough to produce the photoelectric effect in either steel or zinc. Increasing the irradiance of a source increases the number of photons arriving at the surface per second. As there are more photons hitting the metal per second, more electrons will be removed per second. Note that if the photon has sufficient energy, one photon can remove one and only one electron. If the photons do not have enough energy to cause the removal of an electron, increasing the irradiance will make no difference as electrons will still not be removed.

To help visualize the situation we can think of the electrons in an atom as being in a potential energy well like marbles in a bowl, Figure 4.2. As photons strike the electrons they force them up the sides of the well but only photons with sufficient energy can push the electrons over the side, allowing them to escape. If the electrons don't gain enough energy, they fall back inside the atom.

Figure 4.2: The photoelectric model

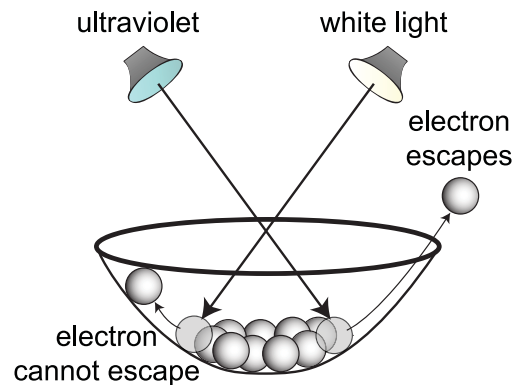

Although we have only considered two sources of electromagnetic radiation, it should be remembered that the electromagnetic spectrum consists of a large range of frequencies and it can be shown that there is a minimum frequency for which **photoemission** will occur for any particular substance. This is known as the **threshold frequency** and is given the symbol f_0 .

4.1.2 Investigating the photoelectric effect

The factors affecting photoelectric emission can be investigated using the apparatus shown in Figure 4.3. The apparatus allows the frequency and irradiance of the electromagnetic source to be altered as well as the type of metal used for the **photocathode**. A quartz window is used as glass would block ultraviolet radiation. The chamber of the apparatus is evacuated and if the radiation causes photoemission, the electrons may have enough energy to reach the anode. This flow of electrons would constitute an electric current detectable by the ammeter. The power supply can be used to produce an electric field between the two electrodes and this can be used to attract or repel the **photoelectrons** to or from the anode. We can use this to find the maximum energy of the photoelectrons.

Figure 4.3: Photoelectric apparatus

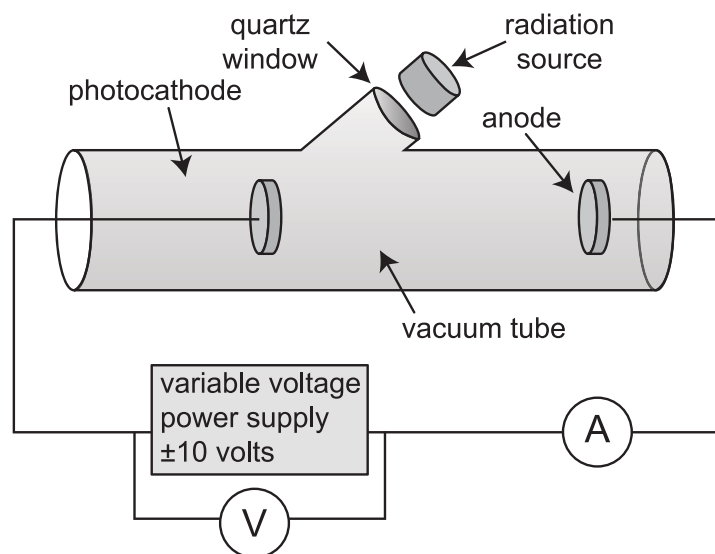

Using the apparatus in Figure 4.3, the following graphs can be produced. Note that the sign of the voltage refers to the polarity of the anode compared to the photocathode so a negative voltage corresponds to the anode being more negative than the photocathode.

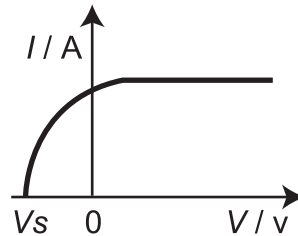

This graph shows current against voltage for a particular material and light source. V_s stands for the **stopping potential**, the minimum negative voltage required to prevent any electrons reaching the anode. As the potential becomes less negative some of the more energetic electrons can overcome the repulsion and reach the opposite electrode and a current is registered. The current does not reach a maximum at zero volts since the electrons are ejected in many directions and so some will not reach the anode.

A positive voltage applied to the anode attracts more of the electrons but there is a maximum current, which occurs when all of the electrons reach the anode. The maximum energy of the electron can be calculated using the equation $E = Q \times V_s$, where Q is the charge on the electron and V_s is the stopping potential.

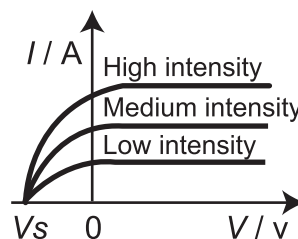

This second graph shows that the maximum current can only be increased by increasing the irradiance of the radiation source. This is due to the fact that more electrons are being released each second. More electrons means more charge and as $Q = I \times t$, this must result in an increased current. Notice that irradiance has no effect on the stopping potential, as the maximum energy of the photoelectrons is determined by the frequency of the light, which is constant here.

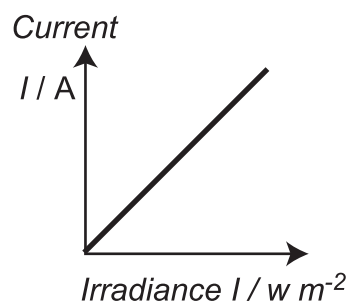

The third graph shows that the photoelectric current is directly proportional to the irradiance of the source for frequencies greater than the threshold frequency (f_0). Note that the source must be **monochromatic**, i.e. it must consist of a single frequency.

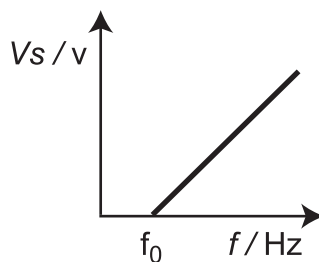

The final graph shows that the stopping potential V_s is directly proportional to the frequency of the source once the frequency exceeds the threshold value (f_0).

4.1.3 Wave particle duality

Physics is an attempt to explain the reality of the universe. It does this by building models (theories) that can predict the result of experiments. The ultimate goal of physics is to produce a single theory that will explain everything, but until that time arrives we must make do with multiple models of the universe.

Although imperfect, the use of multiple models is still very useful. Consider a portrait and a life-size statue of someone: each one can tell us something different about the person but neither gives the complete picture. That does not mean that these works of art have no value.

Theories usually only last until they fail to produce correct results, in which case they are discarded and replaced by new ones, although occasionally they can be retained as special cases of the new theories. The photoelectric effect, however, caused major problems for physicists. There were now two contrasting theories about the nature of light and there seemed to be no way to reconcile them. Which was correct? Was light a wave or was it a particle?

Here the photoelectric effect is explained by stating that "wave packets" called photons cannot join with each other. This makes us think that light is behaving as a particle. Two low energy photons cannot combine to produce one high energy photon. You will see later that in other situations light appears to behave as a wave.

The idea that light can act like a particle troubled many physicists as light showed all the characteristics of a wave: refraction; diffraction; interference. Also, they argued, if light does consist of particles, why do two overlapping light beams not collide with each other in the way that two jets of water would?

As we learn more about the universe, we modify our models to take account of new developments. Light does behave like a wave and it also behaves like a particle but it is only false preconceptions that say it can only be one thing or the other. We now know that particles can have wave-like properties and a diffraction pattern can be created using a beam of electrons.

4.2 Photoelectric calculations

Learning objective

To explain the particle nature of electromagnetic radiation and the relationship between energy and frequency.

To carry out calculations using the relationship $E = hf$.

To explain the relationship between irradiance and number of photons, $I = Nhf$.

To state the relationship between the kinetic energy of photoelectrons, photon energy and the work function of the material, $E_k = hf - hf_0$.

The outcome of investigations into the photoelectric effect was that light can be thought of as consisting of photons, which are essentially small packets of energy. Each photon contains a quantum of energy, the size of which depends only on the frequency of the light. It was shown that the energy of a photon is directly proportional to its frequency and so this led to a new equation:

$$E = hf \quad (4.1)$$

Where E stands for the energy in joules, f is the frequency in hertz and h is the constant of proportionality, called Planck's constant. $h = 6.63 \times 10^{-34} \text{ J s}$.

Example : Photon energy

Calculate the energy of a photon of red light that has a wavelength of 680 nm.

Answer:

We must first calculate the frequency of the light:

$$\begin{aligned} f &= \frac{v}{\lambda} \\ &= \frac{3 \times 10^8}{6.8 \times 10^{-7}} \\ &= 4.4 \times 10^{14} \text{ Hz} \end{aligned}$$

We then use the frequency to calculate the energy:

$$\begin{aligned} E &= hf \\ &= 6.63 \times 10^{-34} \times 4.4 \times 10^{14} \\ &= 2.9 \times 10^{-19} \text{ J} \end{aligned}$$

Using Equation 4.1, we can calculate the minimum energy needed to eject an electron from the surface of a material. This is known as the **work function** of the material and is equal to hf_0 , where f_0 is the threshold frequency of radiation.

Example : Work function

The minimum frequency needed to cause photoemission from a material is found to be 8.4×10^{14} Hz. What is the work function of the material?

Answer:

$$\begin{aligned}\text{work function} &= hf_0 \\ &= 6.63 \times 10^{-34} \times 8.4 \times 10^{14} \\ &= 5.6 \times 10^{-19} \text{ J}\end{aligned}$$

If the radiation incident on a material has a frequency greater than the threshold frequency then electrons will be ejected with a range of kinetic energies. The maximum kinetic energy of any electron is equal to the difference between the photon energy (hf) and the work function hf_0 : $E_k = hf - hf_0$

Example : Electron kinetic energy

The material mentioned in the previous example is irradiated with UV light of frequency 1.5×10^{15} Hz. What is the maximum kinetic energy of the emitted photoelectrons?

Answer:

Maximum kinetic energy of electron = photon energy - work function

$$\begin{aligned}E_k &= hf - hf_0 \\ &= 6.63 \times 10^{-34} \times (1.5 \times 10^{15} - 8.4 \times 10^{14}) \\ &= 6.63 \times 10^{-34} \times 6.6 \times 10^{14} \\ &= 4.4 \times 10^{-19} \text{ J}\end{aligned}$$

4.3 Uses of the photoelectric effect

When taking pictures with a camera it is important to allow the correct amount of light on to the film (or the CCD in digital cameras). If there is too much light the image will appear washed out (overexposed), if there is too little light the image is too dark to distinguish (underexposed).

Most cameras have a built in light meter or exposure meter. This works using the photoelectric effect. When light falls on the cathode in the meter it releases electrons, the higher the irradiance the higher the current. The camera measures this current and adjust the time the camera shutter is open so that the correct exposure is made (Figure 4.4).

The photoelectric effect is also used in photomultipliers and channel plate image intensifiers. In low light conditions these devices can be used to enhance an image. When a photon strikes the cathode it releases an electron. These photoelectrons are then made to strike a further electrode which causes more than one electron to be released. This is repeated several times so that the number of electrons is greatly increased. These electrons are then made to strike a phosphor coated screen. When an electron strikes an area of the phosphor screen light is given off. This will then be visible to an observer.

Figure 4.4: Photograph of the same subject (a) overexposed, (b) correctly exposed, (c) underexposed

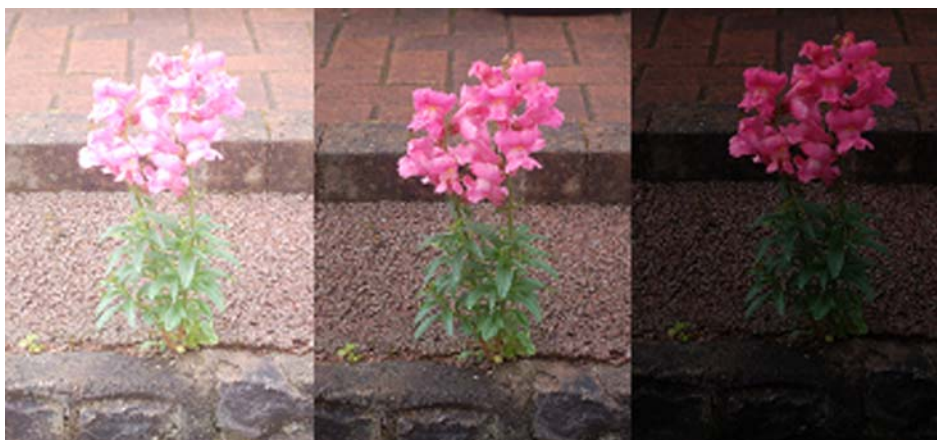

Photoelectric effect: Questions (20 min)

Go online



Data: Planck's constant $h = 6.63 \times 10^{-34} \text{ J s}$

Q6: What is the energy of a photon with a frequency of $7.25 \times 10^{14} \text{ Hz}$?

- a) $9.14 \times 10^{-49} \text{ J}$
- b) $4.81 \times 10^{-19} \text{ J}$
- c) $4.14 \times 10^{-7} \text{ J}$
- d) $2.42 \times 10^6 \text{ J}$
- e) $1.09 \times 10^{48} \text{ J}$

.....

Q7: What is the wavelength of a photon with energy $3.00 \times 10^{-19} \text{ J}$?

- a) $1.00 \times 10^{-27} \text{ m}$
- b) $6.63 \times 10^{-7} \text{ m}$
- c) $4.52 \times 10^{14} \text{ m}$
- d) $1.36 \times 10^{23} \text{ m}$
- e) $1.00 \times 10^{27} \text{ m}$

.....

Q8: The work function of a material is $6.21 \times 10^{-19} \text{ J}$. Which one of the following frequencies of light will eject photoelectrons with the *least* maximum kinetic energy?

- a) $9.1 \times 10^{14} \text{ Hz}$
- b) $9.2 \times 10^{14} \text{ Hz}$
- c) $9.3 \times 10^{14} \text{ Hz}$
- d) $9.4 \times 10^{14} \text{ Hz}$
- e) $9.5 \times 10^{14} \text{ Hz}$

.....

Q9: What is the maximum kinetic energy of electrons emitted from a surface that has a threshold frequency of 8.35×10^{14} Hz when it is illuminated by light of frequency 8.74×10^{14} Hz?

- a) 2.59×10^{-20} J
- b) 5.54×10^{-19} J
- c) 5.79×10^{-19} J
- d) 1.13×10^{-18} J
- e) 6.24×10^{-6} J

4.4 Summary

Summary

You should now be able to:

- state that photoelectric emission from a surface occurs only if the frequency of the incident radiation is greater than some threshold frequency f_0 , which depends on the nature of the surface;
- state that for frequencies smaller than the threshold value, an increase in the irradiance of the radiation at the surface will not cause photoelectric emission;
- state that for frequencies greater than the threshold value, the photoelectric current produced by monochromatic radiation is directly proportional to the irradiance of the radiation at the surface;
- state that a beam of radiation can be regarded as a stream of individual energy bundles called photons, each having an energy $E = hf$, where h is Planck's constant and f is the frequency of the radiation;
- carry out calculations involving the relationship $E = hf$.
- state that photoelectrons are ejected with a maximum kinetic energy E_k , which is given by the difference between the energy of the incident photon hf and the work function of the material hf_0 of the surface: $E_k = hf - hf_0$;
- Use the following terms correctly in context: photon, photon energy, threshold frequency, work function, photoemission of electron and photoelectric current.

4.5 Extended information

Top tip

Links

The authors do not maintain these web links and no guarantee can be given as to their effectiveness at a particular date.

They should serve as an insight into the wealth of information available online and encourage you to explore the subject further.

- University of Colorado: Simulation allowing you to change the photon frequency, irradiance or metal being irradiated.
<http://phet.colorado.edu/en/simulation/photoelectric>
- Britannica: Video clip showing historical background to the development of explanation of photoelectric effect.
<http://www.britannica.com/EBchecked/topic/457841/photoelectric-effect>
- BBC learning zone: Video showing an experiment on the photoelectric effect.
<http://www.bbc.co.uk/learningzone/clips/the-photoelectric-effect/14297.html>
- Youtube: This video talks you through an explanation of the photoelectric effect. Watch out: in this video "intensity" is used while in Higher Physics you must use "irradiance". It also talks about intensity as being the number of photons, more correctly it should be the **irradiance** is related to the **number of photons per second**.
<http://www.youtube.com/watch?v=1avluOIOhOU>
- YouTube: This clip shows you a simple experiment that demonstrates the photoelectric effect. You may be able to try this as most of the equipment is readily available.
<http://www.youtube.com/watch?v=muxRZ1irsrk>

4.6 Assessment

End of topic 4 test

Go online



The following test contains questions covering the work from this topic.



The following data should be used when required:

Planck's constant $h = 6.63 \times 10^{-34} \text{ J s}$

Q10: Calculate the energy, in joules, of a photon of frequency $6.45 \times 10^{14} \text{ Hz}$.

.....

Q11: Radiation, of frequency $3.5 \times 10^{15} \text{ Hz}$ and irradiance 7 mW m^{-2} , produces a photoelectric current of 1.1 mA when incident on a certain material.

What will the photoelectric current be, in mA, if the irradiance of the radiation is increased by a factor of 3?

.....

Q12: What is the work function of a material, in J, if it has a threshold frequency of $1.3 \times 10^{14} \text{ Hz}$?

.....

Q13: Photons of frequency $6.5 \times 10^{15} \text{ Hz}$ are incident on a surface that has a work function of $1.33 \times 10^{-18} \text{ J}$.

Calculate the maximum kinetic energy, in J, of photoelectrons emitted.

Topic 5

Diffraction and interference

Contents

5.1 Diffraction	84
5.2 Interference	85
5.2.1 Young's slits experiment	90
5.2.2 Applications of interference	91
5.2.3 Quiz: Diffraction and interference	92
5.2.4 The grating	93
5.3 Holograms	98
5.4 White light spectra	99
5.4.1 The spectrometer	101
5.5 Summary	104
5.6 Extended information	105
5.7 Assessment	106

Learning objective

By the end of this topic you should be able to:

- explain what is meant by the term 'diffraction';
 - explain what is meant by 'interference';
 - explain the conditions for maxima and minima in an interference pattern, and to carry out calculations using the relationships for maxima and minima;
 - describe the Young's slits experiment;
 - describe what a grating is and its effect on a monochromatic light beam;
 - derive and use the grating equation;
 - explain what is meant by a white light spectrum;
 - describe a spectrometer and state what it is used for;
 - describe and compare spectra produced by different means.
-

We start this topic with a look at how waves diffract when they pass by the edge of a barrier or through a small gap in a barrier. This is expanded to show how a single source of waves can be diffracted through two gaps and therefore act as two coherent sources of waves that can go on to form an interference pattern. This is the basis of an experiment known as Young's double slit experiment.

We will then consider interference of other types of waves.

From double slit interference, we move on to consider interference caused by multiple slits, and this leads on to the grating. The grating equation is introduced and used.

The final part of this Topic considers how white light spectra can be produced in a spectrometer, using the refraction of light by a prism and by the grating. The spectra produced by both means are compared. The principals and uses of holography will also be considered.

5.1 Diffraction

When waves meet the edge of an obstacle, they bend round the corner of the obstacle. Similarly, when waves go through a gap in a barrier, they bend at the edges. This effect is known as **diffraction**. The narrower the gap, the greater is the amount of bending of the waves. This can be seen in Figure 5.1. If the width of the gap in the barrier is equal to, or less than, one wavelength of the waves, then parallel waves emerge from the gap as circular waves. This is shown in Figure 5.1(b).

Figure 5.1: Diffraction of waves through a gap in a barrier

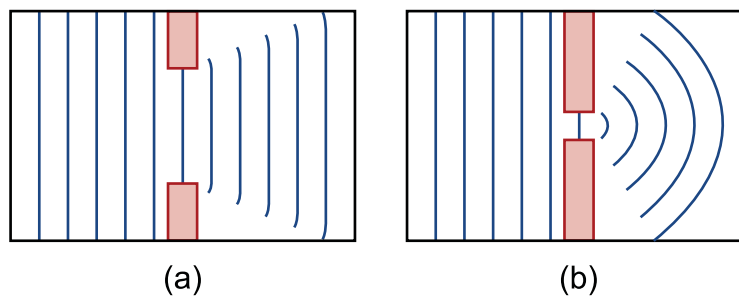

The greater the wavelength the greater the degree of diffraction. The next figure shows a comparison of the diffraction occurring when waves of short and long wavelength pass through gaps of equal width.



The following diagrams show the effect of a wave passing the end of a barrier.

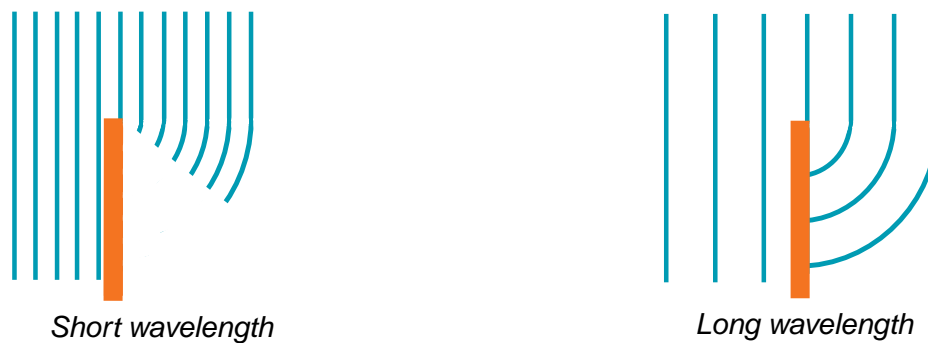

The same effect is noticed with this barrier as with a gap; the longer wavelength the more diffraction there is.

When waves are diffracted, the wavelength, frequency and wave speed are unaffected. Diffraction is a property of waves only - particles do not diffract. Consider, for example, a football kicked through a gap in a fence that is exactly the same width as the diameter of the football. If the football is aimed perfectly, it will not be affected by going through the gap - it does not 'spread out' as it goes through. Diffraction can be used as a test for wave motion - if diffraction can be shown, then the energy is propagated by means of waves.

5.2 Interference

When waves from two coherent sources overlap, they undergo interference. An interference pattern of water waves can be observed in a ripple tank when two sets of **coherent waves** are produced by dippers in the tank. Coherent waves are waves that have the same frequency, speed and have a constant phase relationship. In practice this means that the waves are identical and are in phase with each other. In the discussion that follows if wave sources are described as coherent it means that the sources produce identical waves and when a crest leaves one source a crest leaves the other at the same time.

Microwaves and light can also be shown to exhibit interference. Since microwaves cannot be seen, the interference pattern obtained can only be observed by variations picked up by a detector of microwaves. That aside, it is easier to observe interference of microwaves than interference of light, because of the difference in the wavelengths of the two types of waves. We will look at interference of light later in this topic.

Two sets of coherent microwaves can be produced using one microwave transmitter, by passing the waves through two slits in a barrier. If the slits have a width that is equal to or less than the wavelength of the microwaves, then each slit effectively becomes a source of circular microwaves. The two sets of microwaves so produced are coherent. This means that they are in step when they leave the slits. The experimental arrangement is shown in Figure 5.2.

Figure 5.2: Interference of microwaves

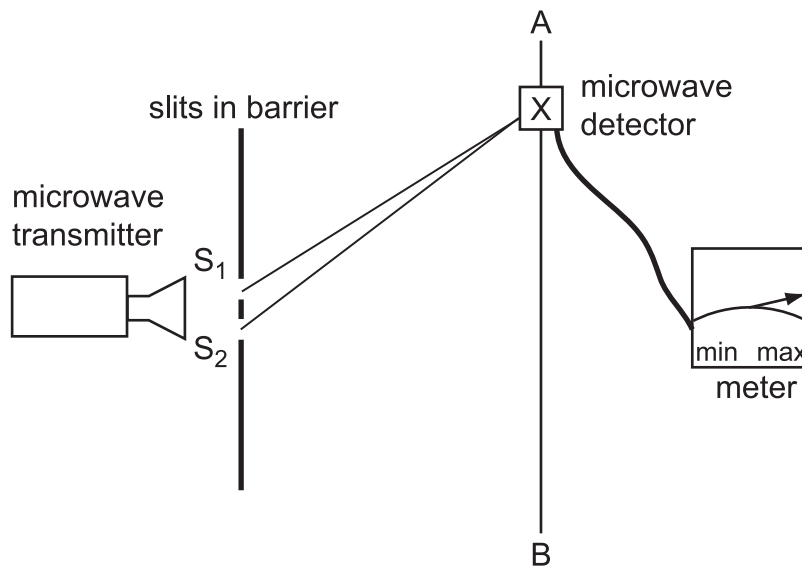

If a microwave detector is moved along the line A-B, the response of the meter is observed to repeatedly increase and decrease in the region from A to B. This is because, as the detector is moved from A to B, it repeatedly goes through points of constructive interference and points of destructive interference.

In Figure 5.2, the two sets of waves that reach the microwave detector have travelled different distances. One set has travelled a distance S_1X and the other set has travelled a distance S_2X . The difference between these two distances, $S_2X - S_1X$, is called the **path difference**. By considering this path difference, we can explain the conditions necessary to produce the maxima and the minima in the interference pattern obtained.

Constructive interference happens at places where two waves meet exactly in step.

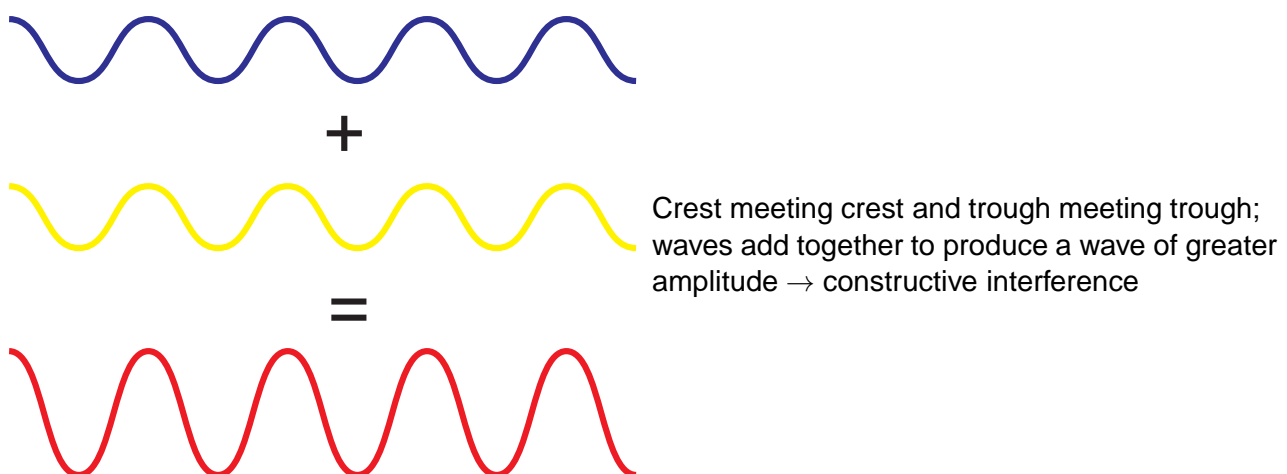

If the microwave detector in Figure 5.2 detects a maximum response to microwaves at some position X , then it follows that both sets of waves detected at X must be in step, or in phase. Since both sets started out in phase (they are coherent) the path difference $S_2X - S_1X$ must be a whole number of wavelengths.

$$\text{path difference} = m\lambda \text{ (for maxima)}$$

(5.1)

(where $m = 0, \pm 1, \pm 2$ and so on)

In a similar way, destructive interference occurs at places where two waves meet exactly out of step.

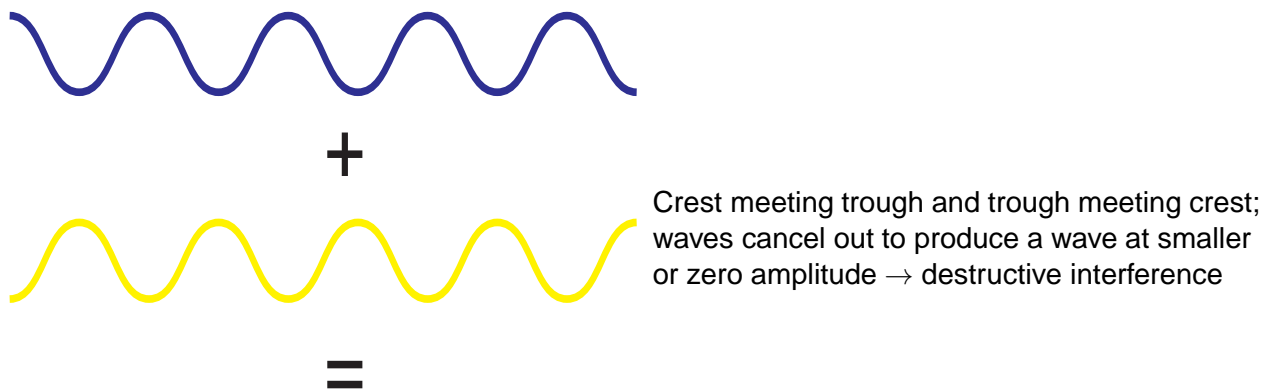

For other points X, in the line A-B, where a minimum response is detected, the two sets of waves must be exactly out of phase or half a wavelength out of step.

Because both sets of waves were in phase on leaving the slits the only way for them to be out of step is if one set has travelled an odd number of half wavelengths more than the other set. In other words, the path difference is an odd number of half wavelengths.

$$\text{path difference} = \left(m + \frac{1}{2}\right) \lambda \text{ (for minima)}$$

(5.2)

(where m is also $0, \pm 1, \pm 2$ and so on)

These conditions for maxima and minima in an interference pattern hold for any type of wave, not just microwaves. Later in this Topic we will use these conditions when we consider the interference of light. It is worth noting that the path differences for maxima and minima depend on the wavelength of the source used, as can be seen in both Equation 5.1 and Equation 5.2. You should also realise that Equation 5.1 and Equation 5.2 relate to different conditions, so the values of m used in both have no relationship to each other.

Example : Path difference of microwaves

Microwaves that have a wavelength of 3.0 cm are passed through two slits in a barrier, as in Figure 5.2. A detector is moved along line A-B from the central position, through two points of minimum response to the third point of minimum response.

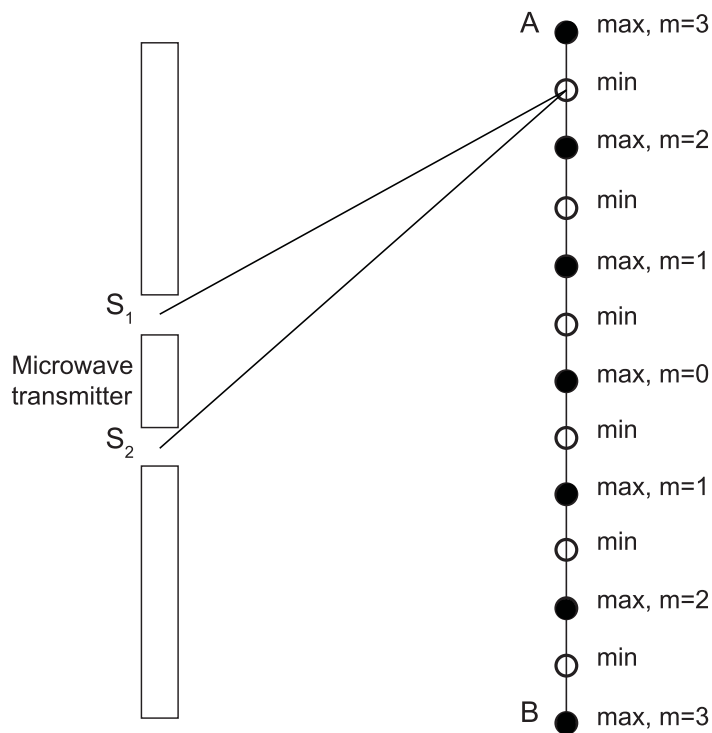

Calculate the path difference at this point.

Answer:

For a minimum response path difference = $(m + \frac{1}{2}) \lambda$

The third minimum response away from the central position corresponds to $m = 2$.

So

$$\begin{aligned} \text{path difference} &= (m + \frac{1}{2}) \lambda \\ &= 2.5 \times 3 \\ &= 7.5 \text{ cm} \end{aligned}$$

Wavelength of microwaves (15 min)

Go online



A microwave source, a pair of slits and a microwave detector are set up as shown.

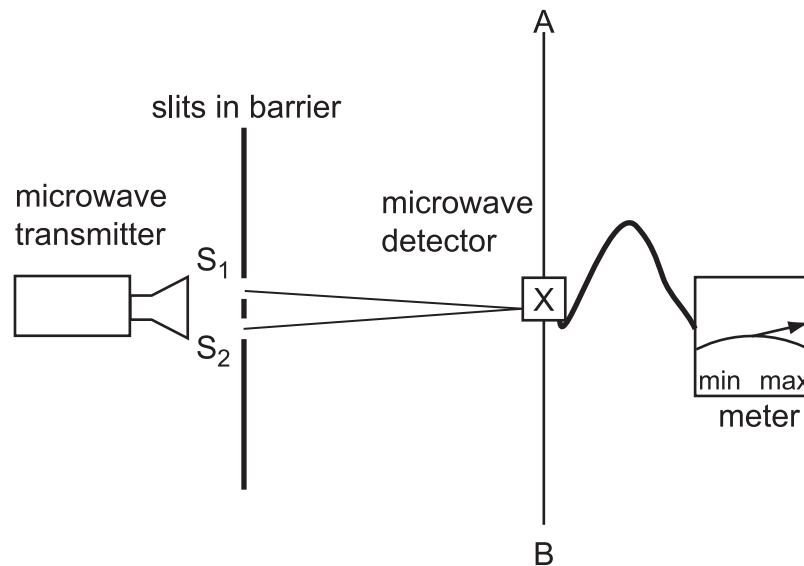

At this point the path difference is zero so the detector gives a maximum reading.

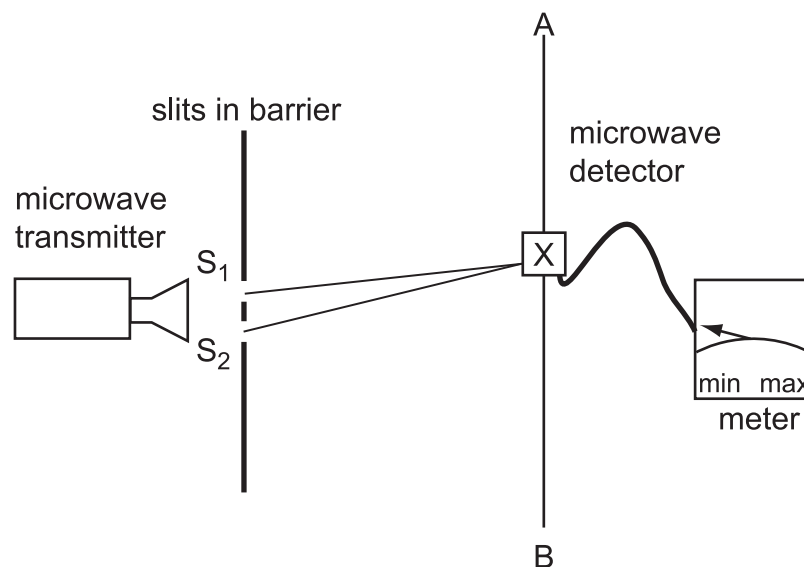

The detector is now moved to the first minimum. At this point the path difference is $\frac{1}{2} \lambda$.

The detector is now moved to the next maximum.

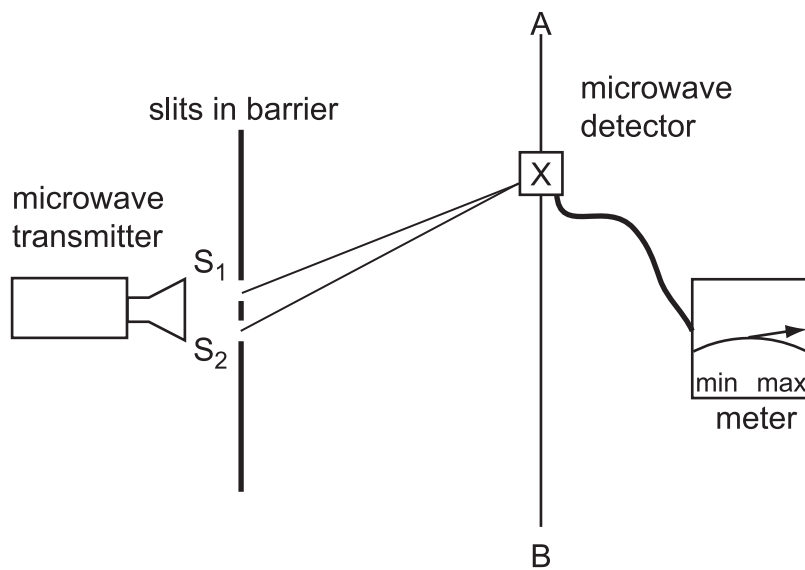

This is the first order maximum. The path difference is equal to λ and this can be measured by finding the difference between distance S_2X and distance S_1X .

The difference between these two distances is the wavelength of the microwaves.

5.2.1 Young's slits experiment

This experiment, which is essentially the same for light as we have just described for microwaves, was first carried out by Thomas Young in 1801. Young split a beam of sunlight into two and showed that the two coherent beams that were produced formed a series of bright and dark lines or 'fringes' on the opposite wall of the room. This was the first time that light had been shown to form an interference pattern, proving that light showed wave properties. One form of the experimental arrangement is shown in Figure 5.3.

Figure 5.3: Young's slits experiment

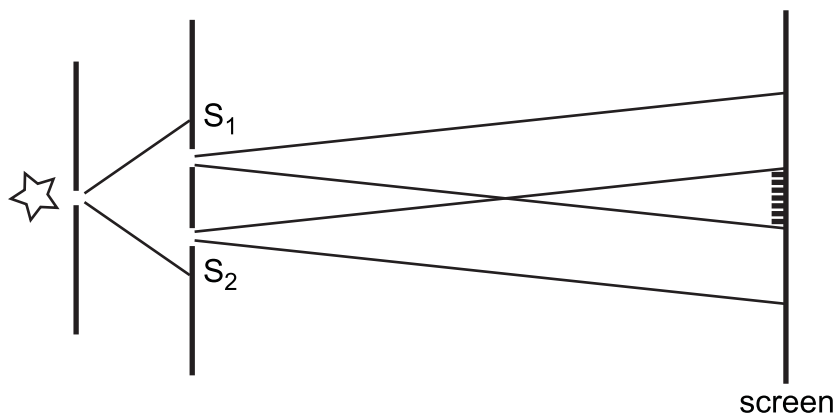

Monochromatic light is passed through one narrow slit and then two further slits to give two coherent sources, as we have seen earlier for microwaves. The two slits are typically a lot less than 1 mm apart, and act as point sources. A screen is placed typically about 1 m from the slits. Where the two beams overlap, a symmetrical pattern of fringes is formed, with a bright fringe at the centre.

Figure 5.4: Young's slits interference fringes

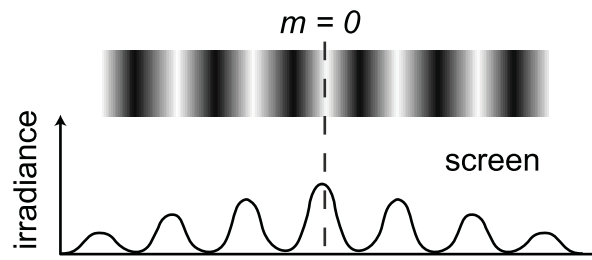

Figure 5.4 shows the fringe pattern seen on the screen. The lower part of Figure 5.4 shows a plot of the irradiance of the light across the screen. The brightest fringe occurs at the centre of the interference pattern as this point is the same distance from both slits, and so the waves arrive exactly in phase. The first dark fringes occur on either side of this when the path difference between the beams is exactly half a wavelength. This is followed by the next bright fringe, due to a path difference of exactly one wavelength, and so on.

In general, a bright fringe occurs when the path difference between the two beams is $m\lambda$, where $m = 0, \pm 1, \pm 2, \dots$. The central bright fringe corresponds to $m = 0$.

$$\text{path difference} = m\lambda \text{ (for maxima)}$$

In a similar way, a dark fringe occurs when the path difference between the two beams is $(m + \frac{1}{2})\lambda$, where m is again $0, \pm 1, \pm 2, \dots$

$$\text{path difference} = (m + \frac{1}{2})\lambda \text{ (for minima)}$$

Since the path difference depends on the wavelength of the light used, it follows that the separation of the bright and dark fringes also depends on the wavelength, and hence the colour, of the light used.

There are two other factors that have an effect on the fringe separation. These are the slit separation and the distance between the screen and the slits.

5.2.2 Applications of interference

All waves will produce an interference pattern. The interference of radio waves was used to guide aircraft in the 1940s. Two transmitters a distance apart sent out low frequency, long wavelength coherent radio waves. When the aircraft detected a maximum the crew knew it was the same distance from each transmitter. This was then used as an aid to navigation.

Mobile phones use either radio waves or microwaves for transmission and reception. The country is divided into cells (hence the American term 'cell phone') each containing a transmitter. When a mobile phone is used the transmitter assigns the mobile phone a unique frequency for transmission and reception. No other phone in the cell will have the same frequency so no phone in the cell experience interference from any other phone. The power of transmitters in mobile phones is limited so phones do not interfere with each other in other cells.

It is not just electromagnetic waves that can interfere, it is a property of all waves. Sound waves can be made to interfere in a school lab. Two speakers are attached to a signal generator. When a student walks across the room in front of the speakers they will hear a series of loud and quiet sounds. The loud areas are caused by constructive interference and the quiet areas by destructive interference. If the student stands in a quiet spot, and then one of the speakers is disconnected the sound will become louder. This is because there is no longer any destructive interference taking place.

Electrons can be made to produce an interference pattern. This may seem to be strange as we normally think of electrons as particles but under certain circumstances they can be shown to produce an interference pattern. This is one of the founding experiments in quantum mechanics and shows that electrons, like light, exhibit a wave/particle duality.

5.2.3 Quiz: Diffraction and interference

Diffraction and interference: Questions (20 min)

Go online



Q1: Diffraction happens when

- a) waves go past the end of a barrier.
- b) a particle goes through a gap in a barrier.
- c) waves reflect off a barrier.
- d) a particle passes close to the edge of a barrier.
- e) waves pass from one medium into another.

.....

Q2: The Young's double slit experiment proves that light is carried by waves because the experiment shows

- a) absorption of waves.
- b) coherence of waves.
- c) interference of waves.
- d) reflection of waves.
- e) refraction of waves.

.....

Q3: In the diagram, X is a point in an interference pattern produced by waves from two coherent sources S_1 and S_2 .

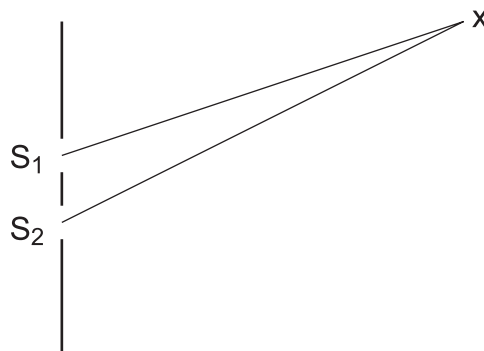

The wavelength of the waves is 4 cm and the distance S_1X is 20 cm.

Which two distances S_2X would mean that X was a point of *maximum* interference?

- a) 22 cm and 23 cm
- b) 24 cm and 28 cm
- c) 24 cm and 26 cm
- d) 22 cm and 26 cm
- e) 26 cm and 28 cm

.....

Q4: In the diagram, X is a point in an interference pattern produced by waves from two coherent sources S_1 and S_2 .

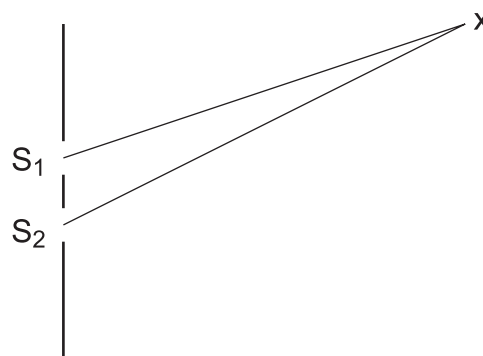

The wavelength of the waves is 4 cm and the distance S_1X is 20 cm.

Which two distances S_2X would mean that X was a point of *minimum* interference?

- a) 22 cm and 23 cm
- b) 24 cm and 28 cm
- c) 24 cm and 26 cm
- d) 22 cm and 26 cm
- e) 26 cm and 28 cm

5.2.4 The grating

The interference pattern produced by using two coherent beams of light obtained from a double slit mask is not very bright. This is because not much light energy passes through two very narrow slits. A far brighter interference pattern is obtained by using a **grating**, which consists of a large number of very finely machined, equally-spaced grooves on the surface of a transparent slide (made of glass or clear plastic). Gratings usually have several hundred lines machined on them every millimetre.

Gratings are normally used with parallel-sided beams of light. Because the separation of the lines on a grating is so small in relation to the viewing distance, the beams of light passing through adjacent grooves are effectively parallel to each other. This is shown in Figure 5.5. Here, only three beams are considered for simplicity but the analysis can be extended to the large number of beams that are produced by shining light through a grating.

Remember from the previous analysis of two slits that there is a maximum at the central viewing position, where the path difference is zero. This also applies in the case we are now considering, with more than two parallel beams. A maximum of light is seen because constructive interference

of all of the rays takes place at this position. This position is known as the zeroth order maximum.

Figure 5.5: Adjacent grooves in a grating

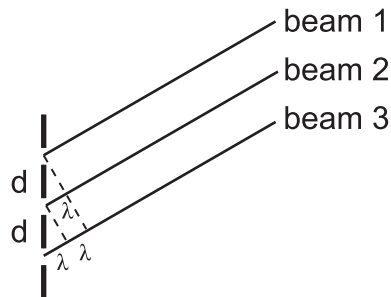

It can be seen in Figure 5.5, for a viewing position that corresponds to constructive interference for beams 1 and 2, the path difference between these beams is 1λ as shown previously for the two slit case. In addition, since all the three beams are parallel, the path difference between beams 2 and 3 is also 1λ . This means that the path difference between beams 1 and 3 is 2λ . This position is known as the first order maximum - the first position round from the central position where a constructive interference pattern can be viewed. All the beams add to the same constructive interference pattern and so the image is brighter. It should be apparent that there are two positions that give rise to first order maxima. These two positions are to be found at equal angles on either side of the zeroth order maximum.

There are several other viewing angles that give rise to constructive interference, and maxima being viewed. Whenever the path difference is an integral number of whole wavelengths the beams reinforce and constructive interference takes place. The next positions out from the first order maxima correspond to path differences between adjacent beams of 2λ . These positions are known as second order maxima.

Figure 5.6: Second order diffraction

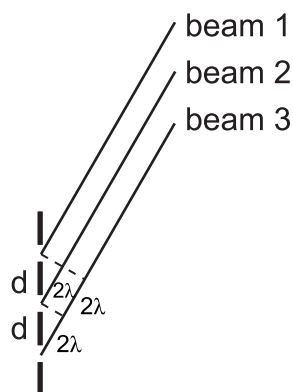

There is a relationship between the viewing angle for constructive interference, θ , the groove or slit spacing, d , the wavelength of the light used, λ , and the order of the maximum, m . This relationship is

$$d \sin \theta = m \lambda$$

(5.3)

Example : Calculating wavelength using a grating

The beam of light from a He-Ne laser is shone through a grating that has 500 lines per millimetre machined on it. The second order maximum is seen at a viewing angle of 39° round from the straight-through position.

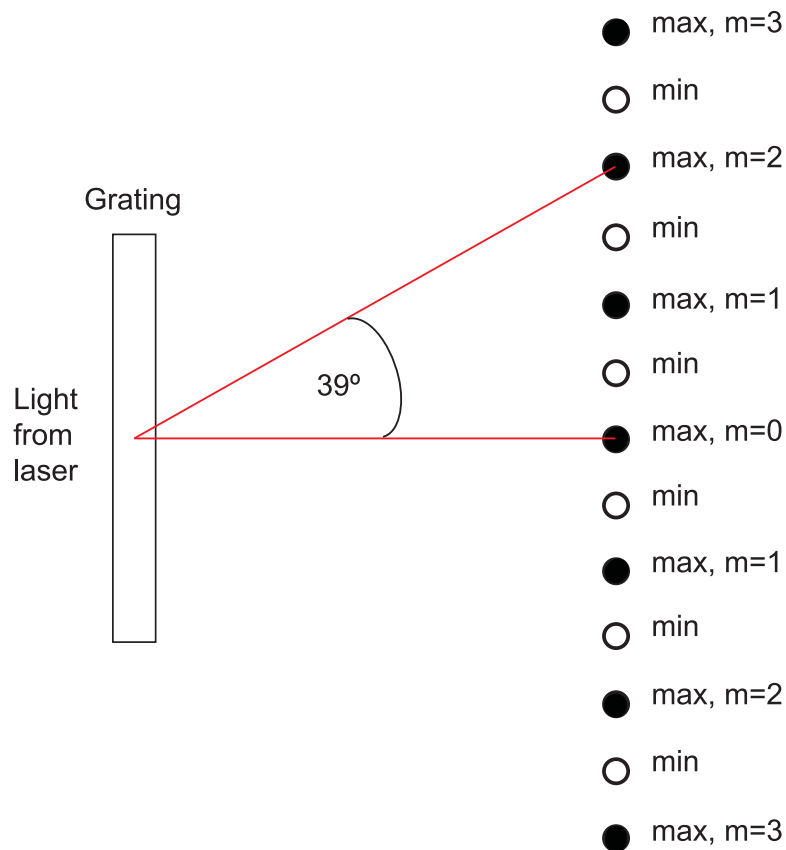

Calculate the wavelength of the He-Ne laser that these results give.

Answer:

In the equation $d \sin \theta = m\lambda$, we have:

$d = \text{slit spacing} = \frac{1}{500} \text{ mm, or } \frac{1}{500} \times 10^{-3} \text{ m}$

$\theta = 39^\circ$

$m = 2$ (second order maximum)

So

$$d \sin \theta = m\lambda$$

$$\therefore \frac{1}{500} \times 10^{-3} \times \sin 39 = 2 \times \lambda$$

$$\therefore \lambda = \frac{\sin 39 \times 10^{-3}}{500 \times 2}$$

$$\therefore \lambda = 0.629 \times 10^{-6}$$

$$\therefore \lambda = 629 \text{ nm (nanometres)}$$

The following *optional* activity takes you through the derivation of the grating equation $d \sin \theta = m\lambda$.



Derivation of the grating equation (15 min)

In the diagram, S_2O is a normal to the grating and in the same figure, the triangle S_1S_2P is right-angled at P . S_2P is the path difference between beam 1 and beam 2.

$$\text{so } \angle PS_1S_2 + \angle S_1S_2P = 90^\circ$$

$$\text{also } \angle PS_2O + \angle S_1S_2P = 90^\circ$$

$$\therefore \angle PS_1S_2 = \angle PS_2O = \theta$$

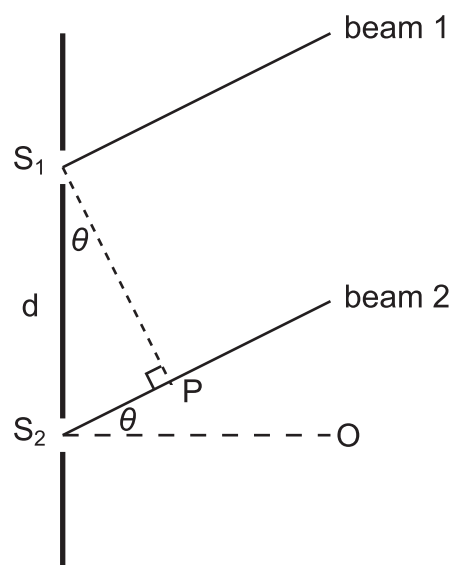

In triangle S_1S_2P ,

$$\sin \theta = \frac{S_2P}{S_1S_2}$$

$$\therefore \sin \theta = \frac{\text{path difference}}{d}$$

$$\therefore \text{path difference} = d \sin \theta$$

We have seen already that the condition for a maximum of light, caused by constructive interference is path difference = $m\lambda$, where $m = 0, 1, 2, 3, \dots$

so, for constructive interference

$$\text{path difference} = d \sin \theta = m\lambda$$

$$\therefore d \sin \theta = m\lambda$$

The following simulation allows you to measure the wavelength of a monochromatic light source, using a grating. It uses the grating equation $d \sin \theta = m\lambda$.

Measuring wavelength with a grating (15 min)

Go online



The apparatus shown below is set up.

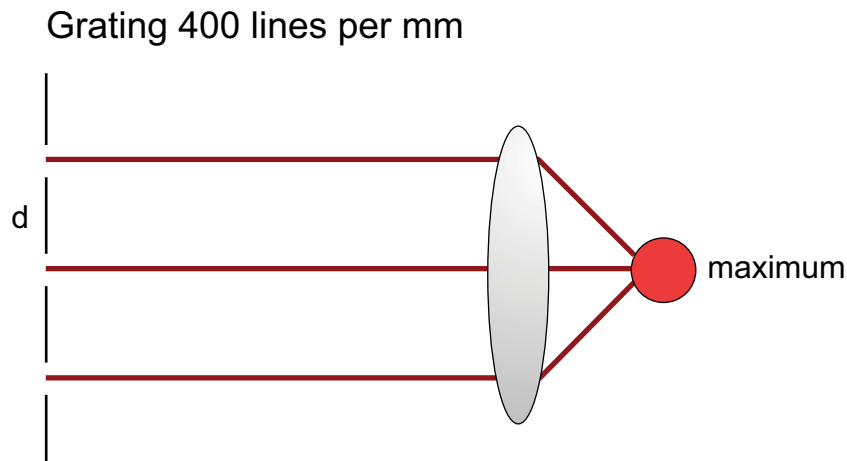

At this point the path difference is zero so a maximum is produced.

The lens is then moved to produce the next maximum.

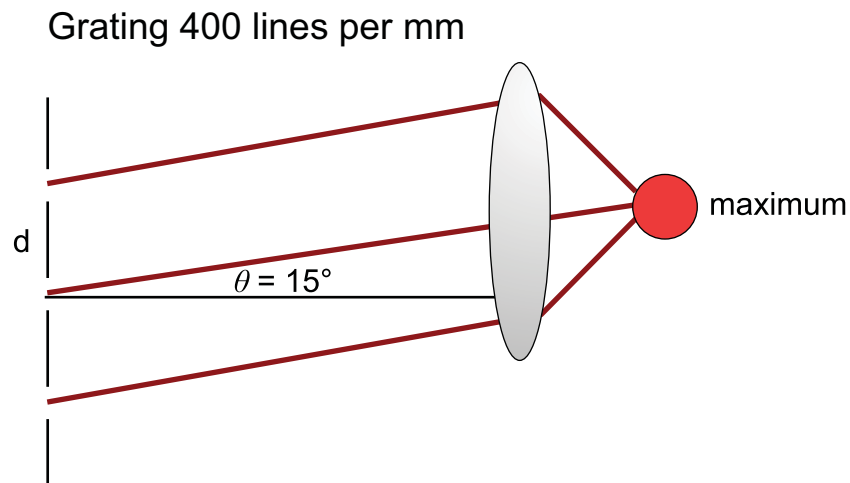

This is the first order maximum so $m = 1$.

We can see the angle is 15° and the grating is 400 lines per millimetre.

We can use this data to calculate the wavelength of the light.

d = the separation of the slits = $1/400 \text{ mm} = 1/400 \times 10^{-3} \text{ m}$

$$\lambda = d \sin \theta / m$$

$$\lambda = 1/400 \times 10^{-3} \times \sin 15 / 1$$

$$\lambda = 647 \text{ nm.}$$

5.3 Holograms

A **hologram** is a virtual image of an object that will appear to be three-dimensional to an observer.

Holograms are produced using an interference pattern. A laser beam is split so that some of the beam strikes the object and reflects onto the recording material. The rest of the beam (known as the reference beam) is reflected on to the recording material without striking the object. When these two beams arrive at the recording material they interfere with each other and the interference pattern is recorded.

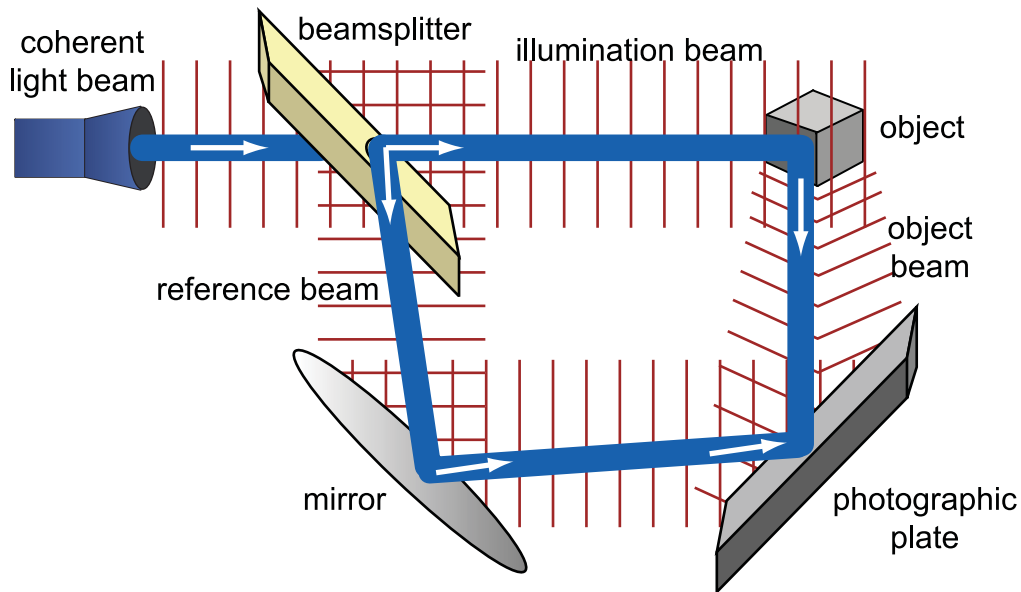

The pattern recorded on the photographic plate looks nothing like the object being photographed. All that is recorded is the interference pattern.

In order for the image to be seen the photographic plate is illuminated with a reconstruction beam. When this passes through the photographic plate and is observed a virtual image is formed on the retina of the observer.

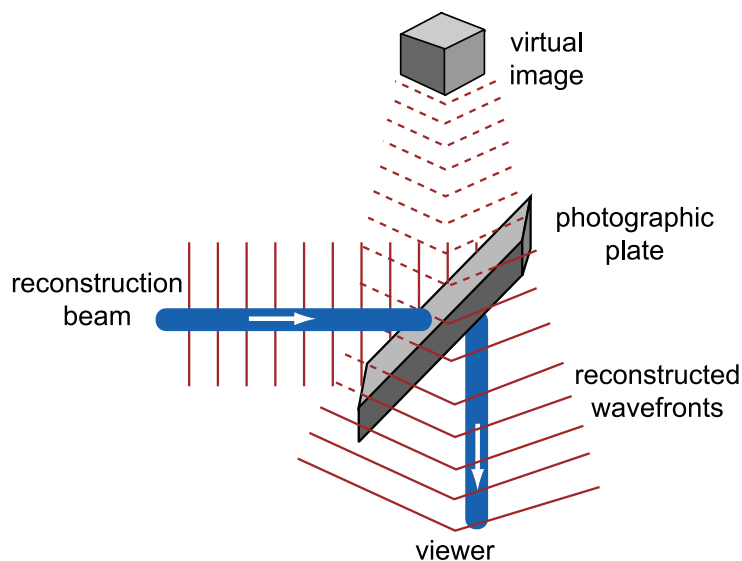

This image will appear to be three dimensional to the observer.

Holography can be used with interferometers to measure stresses and strains in surfaces. An interferometer is used to measure small changes in path difference. When a surface becomes stressed its shape changes slightly. Holograms in combination with interferometers can detect this and the pattern produced can be analysed to measure the stress.

5.4 White light spectra

Visible light consists of radiation that has a wavelength range from about 700 nm for red light, through 560 nm for green light, about 470 nm for blue light to about 400 nm for violet light. These figures are only approximate, since the colours merge into each other. The range of wavelengths is known as a spectrum. Since visible light is a mixture of all of these wavelengths and therefore colours, it is often referred to as 'white light'.

We have seen with the Young's slits experiment that light of different wavelengths produces lines of different separation. The same applies to light that is passed through a grating. When white light is passed through a grating, coloured spectra are seen on either side of the central maximum. Blue light has a shorter wavelength than red light so the blue maximum will appear nearer the central maximum than the red maximum. Each colour will produce a maximum in a slight different position and so the colours spread out into a spectrum. This spread is predicted by the equation $d \sin\theta = m\lambda$.

- Since d and m are constant for a given spectrum and λ_{red} is greater than λ_{blue}
- $\sin\theta$ must be greater for red than blue (by $d \sin\theta = m\lambda$)
- θ must be greater for red than blue
- red more spread out than blue

The pattern produced when white light is passed through a grating is shown in the following diagram. It consists of one white central maximum and a symmetrical pattern of coloured spectra either side of the white central maximum.

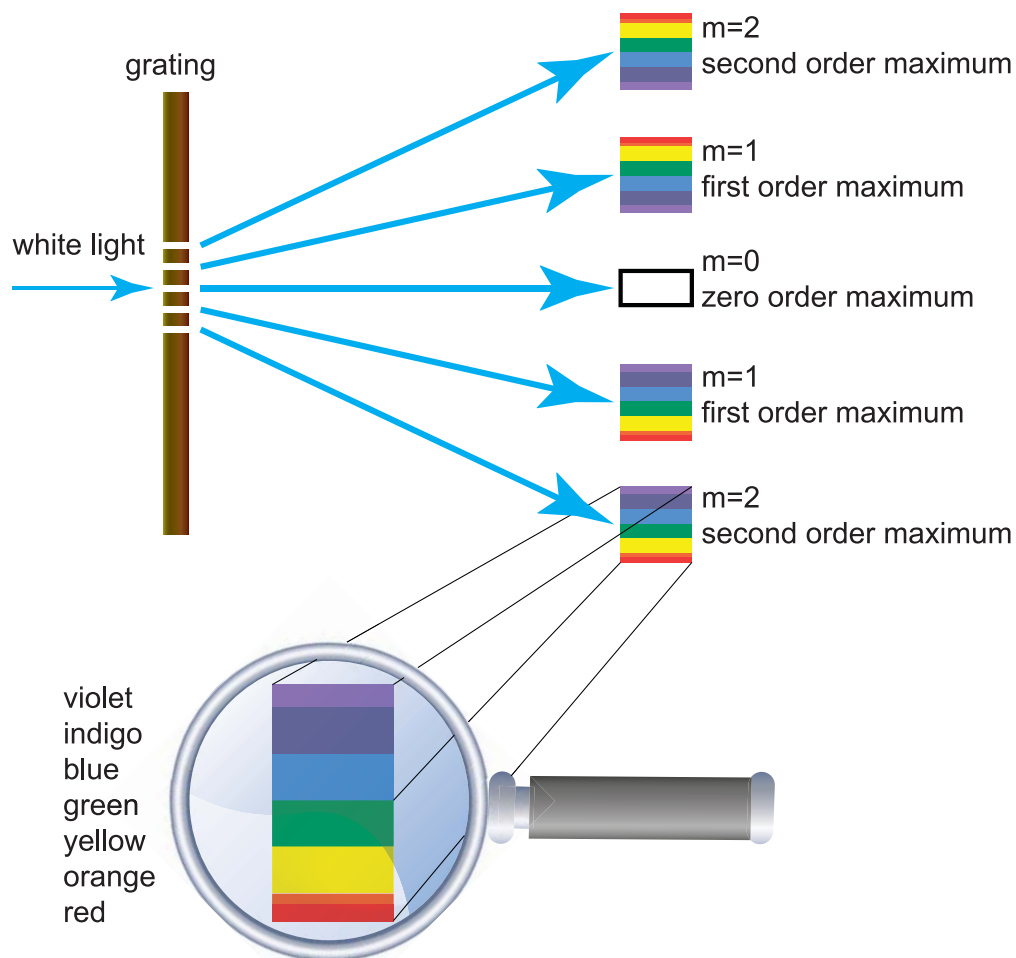

Each maximum, or spectrum or fringe, appears as a visible spectrum, apart from the central white fringe, $m = 0$. Violet, which has the shortest wavelength, is deviated least so is nearest the central maximum. Red, which has the longest wavelength, is therefore deviated most.

The central maximum (the zeroth order maximum) is white since for this maximum only, the path difference is zero and so does not depend on the wavelength of the light. Since the path difference is zero, constructive interference occurs for all the different wavelengths (colours) of light so white light is produced.

A triangular glass or perspex shape called a prism can also be used to produce a spectrum from a white light source. It does this in a different way to a grating. A prism uses refraction and dispersion to produce a spectrum. The next Topic will look more closely at refraction of light.

5.4.1 The spectrometer

A **spectrometer** is an instrument that can make precise measurements of the spectra produced by different light sources. There are three main parts to a spectrometer - the **collimator**, the optical device (either a grating or a prism) mounted on a **turntable**, and the **telescope**. Although not part of the spectrometer, a light source is also needed. For our purposes, we are only considering the spectra produced by a white light source, although the spectrometer can be used to analyse the spectra produced by a variety of light-emitting sources.

A spectrometer with a light source is shown in Figure 5.7. The light source shown is a gas discharge lamp used to produce a particular spectrum consisting of coloured lines, although this does not affect our discussion of the spectrometer.

Figure 5.7: The spectrometer



The collimator, which is seen at the left-hand side of the spectrometer, produces a beam of parallel light. It consists of a tube with an adjustable slit at the end nearest to the light source and a lens system at the turntable end.

In the centre of the spectrometer is a prism, mounted on the turntable. The prism produces a spectrum from the narrow beam of light that emerges from the end of the collimator. A grating could be mounted on the turntable instead of a prism. It is even possible to use a compact disc (CD) as the optical device. The CD acts as a reflection grating because of the series of 'pits' on its surface. The turntable has an angular scale so that precise measurements can be made on the spectrum produced.

On the right-hand side of the spectrometer is the telescope that is used to view the spectrum produced. The telescope is mounted on a swinging arm, so that it can be rotated to view different parts of the spectrum.

White light spectra produced by a prism and a grating (15 min)

Go online



A spectrometer can be used to compare spectra produced by a prism and by a grating. The apparatus shown is set up with a prism on the spectrometer and a white light source.

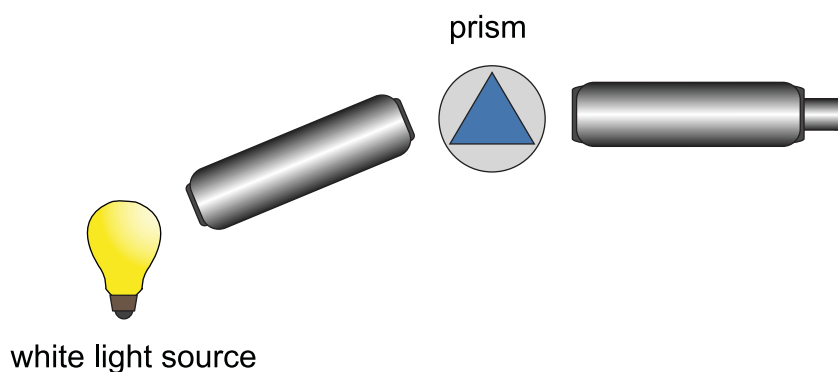

When the telescope is in the central position no light is observed.

As the telescope is moved around the colours of the spectrum are observed. At first the long wavelength, low frequency red is observed and as the angle is increased the wavelength of the observed light increases until the short wavelength, high frequency colours such as blue and violet are observed. Once the spectrum has been observed no more light is observed as the angle is increased. If the telescope is moved in the opposite direction from the central position no light is observed at all.

The prism is now removed and replaced by a grating.

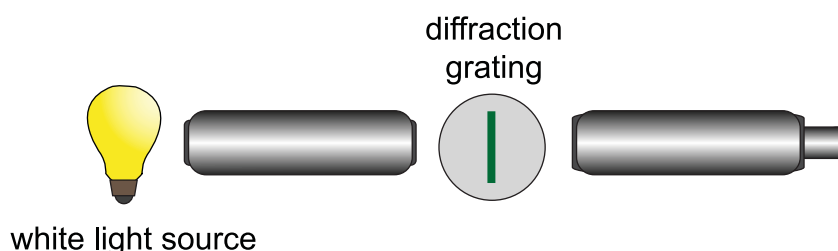

When the telescope is in the central position a white light image of the source is observed.

As the telescope is now moved around the colours of the spectrum again appear but they are in reverse order with the short wavelength, high frequency colours appearing at a smaller angle than the long wavelength, low frequency colours.

When the angle is increase further the pattern repeats itself over again. If the telescope is moved in the opposite direction from the central position the same pattern of results is observed.

You should now realise that both the prism and the grating produce a continuous spectrum of colours from a white light source. These colours are: red, orange, yellow, green, blue, indigo and violet.

You should realise that there are several differences in the spectra produced. These differences are summarised in Table 5.1.

Table 5.1: Spectra produced by a prism and by a grating

	Prism	Grating
Order of colours (deviated least to deviated most)	red, orange, yellow, green, blue, indigo, violet	violet, indigo, blue, green, yellow, orange, red
Central white maximum	no	yes
Number of spectra seen	one only	many, in pairs on both sides of the central white maximum
Spectrum produced by	refraction	interference

The grating and white light spectra: Questions (30 min)

Go online



Q5: A beam of monochromatic light is passed through a grating that has 400 lines per mm. The second order maximum is observed at an angle of 25° to the incident beam.

Calculate the wavelength of the light used.

- a) 383 nm
- b) 528 nm
- c) 541 nm
- d) 554 nm
- e) 583 nm

.....

Q6: Red light, of wavelength 650 nm, is passed through a grating that has 300 lines per mm.

Calculate the angle between the first order maximum and the second order maximum.

- a) 34.2°
- b) 23.0°
- c) 22.5°
- d) 11.7°
- e) 11.2°

.....

Q7: Which of the following statements about a spectrometer is/are correct?

- i. A spectrometer can be used to make precise measurements on spectra.
- ii. A spectrometer consists of a collimator, a turntable and a telescope.
- iii. A spectrometer can only produce a spectrum from a white light source.

- a) (i) only
- b) (ii) only
- c) (iii) only
- d) (i) and (ii) only
- e) (ii) and (iii) only

.....

Q8: What are the approximate wavelengths of light of each of the three colours blue, green and red?

- a) blue - 700 nm, green - 560 nm, red - 470 nm
 - b) green - 700 nm, red - 560 nm, blue - 470 nm
 - c) red - 700 nm, blue - 560 nm, green - 470 nm
 - d) green - 700 nm, blue - 560 nm, red - 470 nm
 - e) red - 700 nm, green - 560 nm, blue - 470 nm
-

Q9: Which of the following statements about the white light spectra produced by a prism and a grating is/are correct?

- i. Only one spectrum is produced by a prism, but several are produced by a grating.
- ii. Of all the colours, red light is deviated least by a prism, but most by a grating.
- iii. The spectrum is produced by refraction in a prism, but by interference in a grating.

- a) (i) only
- b) (ii) only
- c) (iii) only
- d) (i) and (iii) only
- e) (i), (ii) and (iii)

5.5 Summary

Summary

You should now be able to:

- explain what is meant by the term 'diffraction';
- explain what is meant by the term 'interference';
- explain the conditions for maxima and minima in an interference pattern formed by two coherent sources in the form:
 path difference = $m\lambda$ (for maxima) where m is an integer;
 and path difference = $(m + \frac{1}{2})\lambda$ (for minima), where m is also an integer;
- carry out calculations using the relationships for path difference in an interference pattern;
- describe what a grating is and its effect on a monochromatic light beam;
- describe Young's slits experiment;

Summary continued

- carry out calculations using the grating equation $d \sin \theta = m\lambda$;
- describe the principles of a method for measuring the wavelength of a monochromatic light source, using a grating;
- explain what is meant by a white light spectrum;
- state approximate values for the wavelengths of red, green and blue light;
- state two means of producing a white light spectrum;
- describe a spectrometer and state what it is used for;
- describe and compare the white light spectra produced by a grating and by a prism.

5.6 Extended information

Top tip**Links**

The authors do not maintain these web links and no guarantee can be given as to their effectiveness at a particular date.

They should serve as an insight into the wealth of information available online and encourage you to explore the subject further.

- University of Salford: This applet simulates water waves and allows gap width to be changed. It then goes on to demonstrate two slit diffraction which leads to interference.
<http://www.acoustics.salford.ac.uk/feschools/waves/diffract3.php>
- University of Hawaii: This applet simulates diffraction of light waves and allows wavelength (colour) and gap width to be changed. Ignore the equation as it's not relevant for Higher Physics.
<http://www.phys.hawaii.edu/~teb/optics/java/slitdiffr/>
- University of Salford: This animation represents diffraction of radio waves around a hill.
<http://www.acoustics.salford.ac.uk/feschools/waves/diffract2.php#radiotv>
- Physics Classroom: This page introduces interference of light. It has some animations embedded in the text.
<http://www.physicsclassroom.com/class/light/u12l1b.cfm>
- Wikispaces: The first 5 pages (1175 - 1180) of this PDF (880 KB) contain some lovely images on interference.
<http://echspysics.wikispaces.com/file/view/APPhysicsCH37.pdf>
- University of Virginia: This excellent interactive site simulates interference of light waves.
http://galileoandinstein.physics.virginia.edu/more_stuff/flashlets/youngexpt4.htm

5.7 Assessment

End of topic 5 test (30 min)

Go online



Q10: A Young's slits experiment is carried out using monochromatic light of wavelength 650 nm.

Calculate the path difference, in nm, between the two rays of light that cause the first dark fringe on either side of the central bright fringe.

.....

Q11: Microwaves are sent through two slits, S_1 and S_2 , in a barrier.

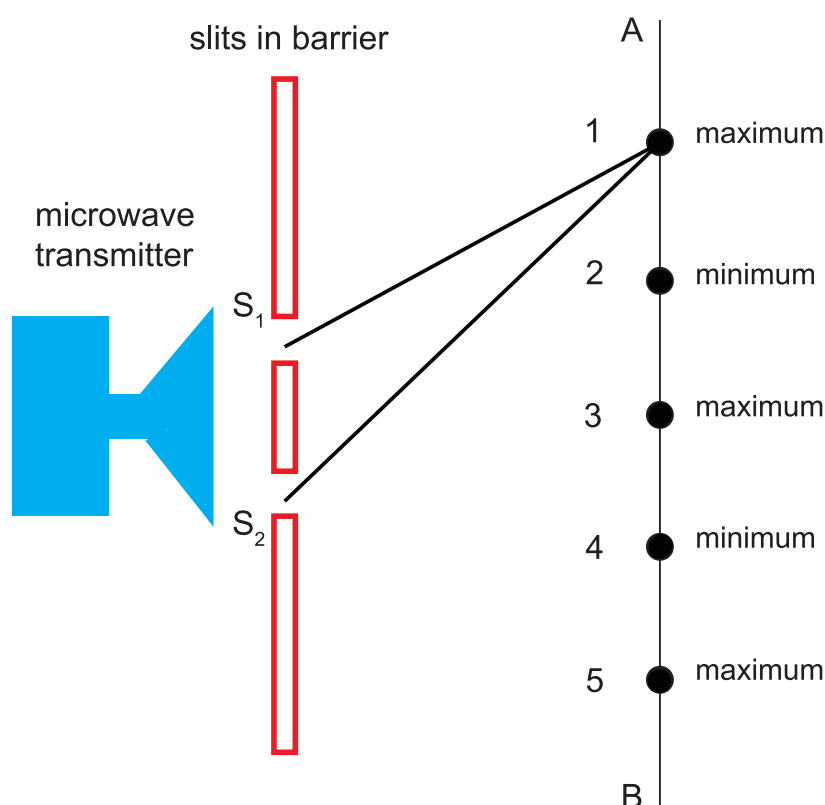

A microwave detector moved between A and B detects adjacent points of maximum and minimum response, marked 1 to 5 in the diagram.

The table shows some of the distances from the slits to the points 1 to 5.

Point	Distance from S_1 (m)	Distance from S_2 (m)
1	1.78	1.82
2	1.79	
3	1.80	1.80
4	1.81	1.79
5		1.78

- a) What two properties of waves cause this pattern of maximum and minimum response?
- Refraction and diffraction
 - Refraction and interference
 - Interference and reflection
 - Reflection and refraction
 - Diffraction and interference
- b) What is the path difference, in cm, for point 1?
- c) What is the path difference, in cm, for point 1?
- d) How far is point 2 away from S_2 , in m?
- e) How far is point 5 away from S_1 , in m?
- f) Calculate the wavelength of the microwaves and give your answer in cm.
- g) In what way would the response of the microwave detector change along line A-B if microwaves with a slightly higher frequency were used?
- Points 1 to 5 would be further apart.
 - The response would be always at the minimum level.
 - The response would be always at the maximum level.
 - Points 1 to 5 would be closer together.
 - No response would be detected.

.....

Q12: A beam of white light is passed normally through a grating that has 500 lines/mm ruled on it.

The light contains a range of wavelengths from 400 nm to 700 nm.

- a) What colours correspond to the extremes of the wavelength range for the light?
- 400 nm - green; 700 nm - red
 - 400 nm - violet; 700 nm - green
 - 400 nm - violet; 700 nm - red
 - 400 nm - red; 700 nm - blue
 - 400 nm - blue; 700 nm - green
- b) Describe the second order maximum that is seen.
- Two spectra of colours on each side of the 'straight- through' position with the red deviated least.
 - A spectrum of colours on each side of the 'straight- through' position with the red deviated least.
 - Two spectra of colours on each side of the 'straight- through' position with the red deviated most.
 - A spectrum of colours on each side of the 'straight- through' position with the red deviated most.
 - A band of white light visible in the 'straight-through' position.
- c) Calculate the angle, in degrees, between the extremes of the second order maximum. State your answer to one tenth of a degree.

Topic 6

Refraction of light

Contents

6.1 Refractive index	110
6.1.1 Refraction and frequency	114
6.1.2 Refraction, wavelength and wave speed	116
6.1.3 Dispersion of laser beams	121
6.2 Total internal reflection and critical angle	121
6.3 Applications of total internal reflection	125
6.4 Summary	128
6.5 Extended information	129
6.6 Assessment	130

Learning objective

By the end of this topic you should be able to:

- understand what is meant by the refractive index of a medium;
 - carry out calculations using the relationship for refractive index;
 - explain that the frequency of a wave is unaltered by a change in medium;
 - explain that the refractive index depends on the frequency of the incident light;
 - explain and use the relationships $\frac{\sin \theta_1}{\sin \theta_2} = \frac{\lambda_1}{\lambda_2} = \frac{v_1}{v_2}$;
 - explain what is meant by total internal reflection and the critical angle;
 - derive and use the relationship for the critical angle for a medium.
-

When a wave goes from one medium to another it is refracted. If the wave goes from a less dense medium into a more dense medium (such as a light ray going from air into glass) and the wave direction is not along the normal, then the direction of the ray in the more dense medium is changed so that the wave direction is closer to the normal. You should be familiar with the terms **refraction**, **normal**, **angle of incidence**, **angle of refraction**.

This topic investigates the relationship between the angles of incidence and refraction and introduces a new quantity, called the refractive index. Refraction has many applications - lenses, optical fibres and the prism, to give a few examples.

These and other uses of the property of refraction are investigated.

Under some circumstances, light does not refract when it meets a boundary between two transparent media. Instead it is reflected back inside the original medium. This property, known as total internal reflection, is covered in the second part of the topic. Included also is the derivation and application of the expression for the critical angle - the angle at which refraction ceases and total internal reflection starts. The topic ends with a brief look at applications of total internal reflection.

6.1 Refractive index

Refraction happens when a wave goes from one medium into another. If, for example, a ray of light travelling in air meets a glass block, the ray of light slows down when it enters the glass. This change in velocity may cause the direction of the ray of light to change (as long as it was not travelling along the normal) so that its new direction is closer to the normal. Refractive index, n , is unusual in that it is just a number, it has no unit.

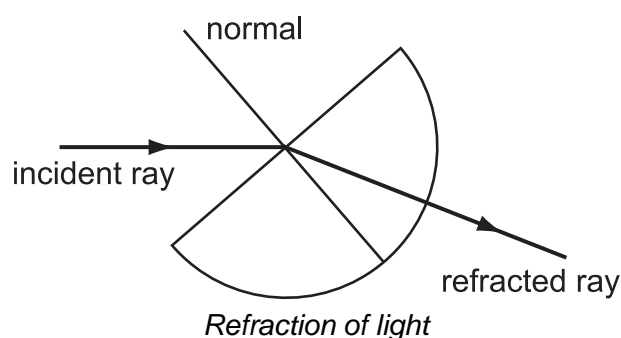

There is a relationship between the angle of incidence and the angle of refraction for monochromatic light. The following activity is designed to let you observe this effect, and to deduce the relationship.

Refractive index of a medium (20 min)

Go online



The apparatus shown below is set up.

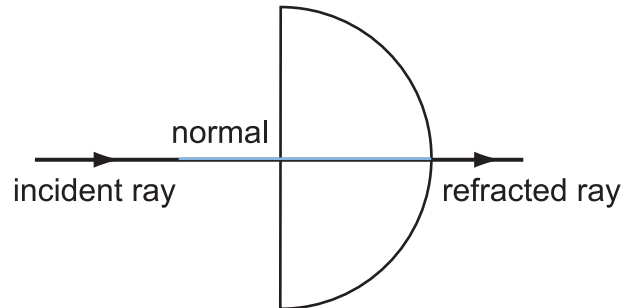

The angle in air is increased and the angles in air and the medium are noted.

Results

angle between the normal and ray in air, θ_1 ($^\circ$)	angle between the normal and ray in substance, θ_2 ($^\circ$)	$\sin \theta_1$	$\sin \theta_2$	$\frac{\sin \theta_1}{\sin \theta_2}$
5	3	0.087	0.052	1.67
10	6	0.174	0.104	1.66
15	9	0.259	0.156	1.65
20	12	0.342	0.208	1.65
25	15	0.422	0.259	1.63
30	18	0.500	0.309	1.62
35	21	0.573	0.358	1.60
40	24	0.643	0.407	1.58
45	26	0.707	0.438	1.61
50	29	0.766	0.485	1.58
55	31	0.819	0.515	1.59
60	33	0.866	0.544	1.59
65	35	0.906	0.573	1.58
70	36	0.939	0.588	1.60
75	37	0.966	0.602	1.61
80	38	0.985	0.615	1.60
85	39	0.996	0.629	1.58
90	39	1.000	0.629	1.59

We can see that the ratio of $\sin \theta_1$ to $\sin \theta_2$ is a constant within experimental uncertainty. The experimental uncertainty at small angles is much higher than with large angles. If the uncertainty in measuring the angle is $\pm 0.5^\circ$ then the percentage uncertainty in 3° is

$$\frac{0.5}{3.0} \times 100\% = 17\%$$

If the same absolute uncertainty is applied to 39° the percentage uncertainty is

$$\frac{0.5}{39} \times 100\% = 1.3\%$$

This is why the results in the latter half of the table are much more consistent.

You should be able to state that the ratio $\sin \theta_1 / \sin \theta_2$ is a constant when monochromatic light passes from medium 1 to medium 2.

You should be able to describe the principles of a method for measuring the absolute refractive index of glass for monochromatic light.

The simulation should have shown you that

$$\frac{\sin \theta_1}{\sin \theta_2} = \text{constant} \quad (6.1)$$

The constant in Equation 6.1 is a property of the two media involved (in this case, air and glass). The **absolute refractive index**, n , of a medium is the ratio $\frac{\sin \theta_1}{\sin \theta_2}$, where θ_1 is in a vacuum, and θ_2 is in the medium. In practice, there is very little difference in the value of n when θ_1 is in air from that when θ_1 is in a vacuum, so the value of the constant obtained from Equation 6.1 is taken as the absolute refractive index of medium 2. Absolute refractive index is often shortened to simply 'refractive index'.

$$\frac{\sin \theta_{\text{vacuum or air}}}{\sin \theta_{\text{medium}}} = n_{\text{medium}} \quad (6.2)$$

The refractive index of a medium or substance is a measure of the ability of the substance to change the direction of a beam of light. The values vary from about 1.0003 for air (which becomes 1.00 to 3 significant figures) to 2.62 for rutile (crystalline titanium dioxide). Some values of refractive index are given in Table 6.1. It is worth noticing that the value of refractive index, n , for all substances is greater than one. Refractive index, n , is unusual in that it is just a number, it has no unit.

Table 6.1: Refractive index of some common substances

Substance	Refractive index (n)
ice	1.31
diamond	2.42
glass	1.50 - 2.00
perspex	1.50
water	1.33

You should be able to describe the principles of a method for measuring the absolute refractive index of glass, n_{glass} , for monochromatic light. You should also be able to carry out calculations using Equation 6.2.

Examples

1. Refractive index of water

The diagram shows the path of a ray of light as it passes from air into water.

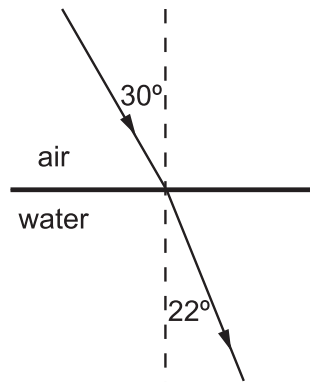

Calculate the refractive index of water that these figures show.

Answer:

The refractive index of water is found using the relationship $n_{\text{water}} = \frac{\sin \theta_{\text{air}}}{\sin \theta_{\text{water}}}$, so

$$n_{\text{water}} = \frac{\sin \theta_{\text{air}}}{\sin \theta_{\text{water}}}$$

$$n_{\text{water}} = \frac{\sin 30}{\sin 22}$$

$$n_{\text{water}} = \frac{0.50}{0.37}$$

$$n_{\text{water}} = 1.33$$

.....

2. Absolute refractive index

The following results were obtained when a ray of monochromatic light was sent from air into a perspex block.

Angle between normal and ray in air, θ_1 ($^\circ$)	Angle between normal and ray in perspex, θ_2 ($^\circ$)	$\sin \theta_1$	$\sin \theta_2$
5.0	3.3	0.087	0.058
15	10	0.259	0.174
25	16	0.423	0.276
35	23	0.574	0.391
45	28	0.707	0.469
55	33	0.819	0.545
65	37	0.906	0.602
75	40	0.966	0.643
85	42	0.996	0.669

Calculate the value of the absolute refractive index of perspex, n_{perspex} , that these results give.

Answer:

To find the average value of the refractive index n from this set of experimental results, plot a graph of $\sin\theta_{1(\text{air})}$ against $\sin\theta_{2(\text{perspex})}$.

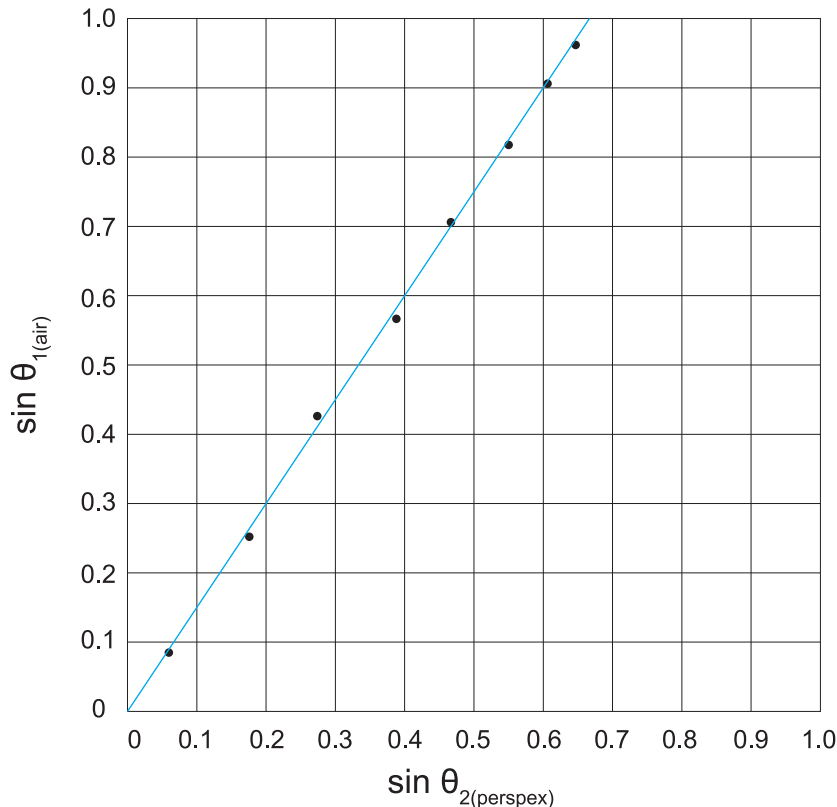

Calculate the gradient of the graph.

$$n = \frac{y_2 - y_1}{x_2 - x_1} = \frac{\text{change in } \sin \theta_{1(\text{air})}}{\text{change in } \sin \theta_{2(\text{perspex})}} = 1.50$$

6.1.1 Refraction and frequency

The frequency of a wave is determined by the source that generated the wave. As a consequence of this, no matter what happens to a wave after it has been generated, its frequency does not change. This means that, when a light wave passes from one medium into another (when it is refracted) its frequency is unaltered.

However, the refractive index of a medium *does* depend on the frequency of the incident light. Since wavelength and colour of light also depend on frequency, it follows that light of different wavelengths and therefore different colours will be refracted by different amounts. If a beam of white light is refracted by a triangular glass prism, it is found that the white light is spread out to form a spectrum. The red end of the spectrum is deviated least from the original direction, while the violet end is deviated most.

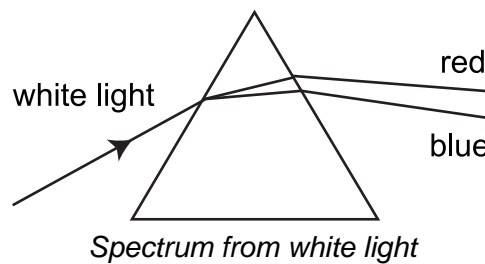

As can be seen in the picture above, red light is deviated least by the prism; this means that it has the smallest refractive index. Red light has the smallest refractive index since it has the lowest frequency of all the different waves (colours) in the visible spectrum.

Blue (violet) light is deviated most hence it must have the greatest refractive index. This is because blue has the highest frequency of the different waves (colours) in the visible spectrum.

Because the refractive index of glass depends on the frequency of the incident light, a glass lens will change the paths of different colours of light by different amounts. This can be overcome by making a lens used for high quality work over a range of frequencies out of two elements. Each of the elements is made from different types of glass with different refractive indices. Such a lens is called an **achromatic doublet**. A cut diamond sparkles because diamond has such a high value of refractive index.

The way a diamond is cut enhances the sparkle by allowing a lot of light to be refracted out of the top faces. The colours are seen in a diamond's sparkle because of the fact that the refractive index depends on the frequency (and so the colour) of the incident light.

Example : Refractive index and colour

A ray of white light passes from air into glass as shown below.

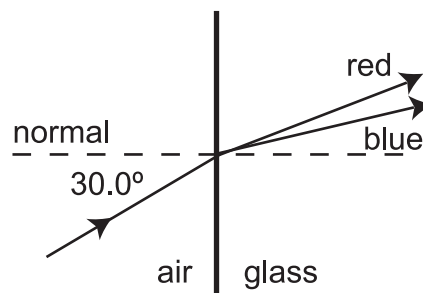

The refractive index of the glass is 1.65 for red light and 1.68 for blue light.

Calculate the angle between the red light and the blue light in the glass (the angle of **dispersion**).

Answer: The refractive index of glass is given by the expression $n_{\text{glass}} = \frac{\sin \theta_{\text{air}}}{\sin \theta_{\text{glass}}}$. So for the red light:

$$1.65 = \frac{\sin 30.0^\circ}{\sin \theta_{\text{red light}}}$$

$$\therefore \sin \theta_{\text{red light}} = \frac{\sin 30.0^\circ}{1.65}$$

$$\therefore \sin \theta_{\text{red light}} = \frac{0.50}{1.65}$$

$$\therefore \sin \theta_{\text{red light}} = 0.303$$

$$\therefore \theta_{\text{red light}} = 17.6^\circ$$

For the blue light:

$$1.68 = \frac{\sin 30.0^\circ}{\sin \theta_{\text{blue light}}}$$

$$\therefore \sin \theta_{\text{blue light}} = \frac{\sin 30.0^\circ}{1.68}$$

$$\therefore \sin \theta_{\text{blue light}} = \frac{0.50}{1.68}$$

$$\therefore \sin \theta_{\text{blue light}} = 0.298$$

$$\therefore \theta_{\text{blue light}} = 17.3^\circ$$

The angle between the red light and the blue light in the glass (the angle of dispersion) is $17.6 - 17.3 = 0.3^\circ$.

6.1.2 Refraction, wavelength and wave speed

We have already noted that when light is refracted, its frequency is unaltered. This is not the case with the wavelength and the speed of a wave. On refraction, both the wavelength and the speed of a wave change. When a wave passes from an optically less dense medium to an optically more dense medium, both its wavelength and its speed decrease.

There are relationships that link the wavelengths and speeds of a wave in different media to the paths that the rays take in the media. When a wave refracts from medium 1 into medium 2 then the following relationships hold.

$$\frac{\sin \theta_1}{\sin \theta_2} = \frac{\lambda_1}{\lambda_2} = \frac{v_1}{v_2}$$

Where θ_1 = angle between wave and normal in medium 1

θ_2 = angle between wave and normal in medium 2

λ_1 = wavelength of wave in medium 1

λ_2 = wavelength of wave in medium 2

v_1 = wave speed in medium 1

v_2 = wave speed in medium 2.

If medium 1 is a vacuum, or air as a close approximation, then these relationships become (for any medium)

$$n_{\text{medium}} = \frac{\lambda_{\text{air or vacuum}}}{\lambda_{\text{medium}}} = \frac{v_{\text{air or vacuum}}}{v_{\text{medium}}} \quad (6.3)$$

Because the speed of a wave is always less in a medium than it is in air or a vacuum, Equation 6.3 shows us that n_{medium} is always greater than one.

Example : Refraction, wavelength and speed

A ray of white light passes from air into glass as shown in Figure 6.1.

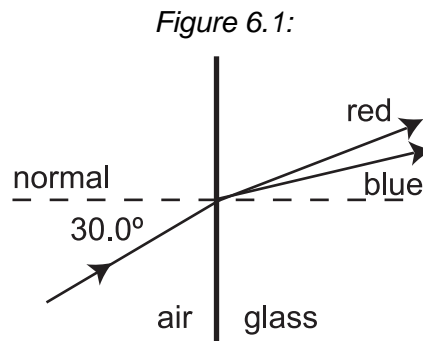

The refractive index of the glass is 1.65 for red light and 1.68 for blue light. The speed of the light in air is $3.00 \times 10^8 \text{ m s}^{-1}$.

1. Calculate the speed of the red light in the glass.
2. Taking the wavelength of the red light in air as 700 nm, calculate the wavelength of the red light in the glass.

Answer:

1. Using the relationship given in Equation 6.3 we have, for the red light:

$$n_{\text{glass}} = \frac{v_{\text{air}}}{v_{\text{glass}}}$$

$$\therefore 1.65 = \frac{3.00 \times 10^8}{v_{\text{glass}}}$$

$$\therefore v_{\text{glass}} = \frac{3.00 \times 10^8}{1.65}$$

$$\therefore v_{\text{glass}} = 1.82 \times 10^8 \text{ m s}^{-1}$$

2. And also for the red light:

$$n_{\text{glass}} = \frac{\lambda_{\text{air}}}{\lambda_{\text{glass}}}$$

$$\therefore 1.65 = \frac{700 \times 10^{-9}}{\lambda_{\text{glass}}}$$

$$\therefore \lambda_{\text{glass}} = \frac{700 \times 10^{-9}}{1.65}$$

$$\therefore \lambda_{\text{glass}} = 424 \text{ nm}$$

Q1: For the example given above:

1. Calculate the speed of the blue light in the glass.
2. Taking the wavelength of the blue light in air as 400 nm, calculate the wavelength of the blue light in the glass.

Refraction of light, wavelength and speed (15 min)



This is an optional activity, showing the derivation of the relationships $\frac{\sin \theta_1}{\sin \theta_2} = \frac{\lambda_1}{\lambda_2} = \frac{v_1}{v_2}$.

Consider a wave of wavelength λ_1 travelling in medium 1, which meets the boundary of medium 2 at an angle of θ_1 . The wave refracts and continues at an angle of θ_2 in medium 2 with a new wavelength λ_2 . This is shown.

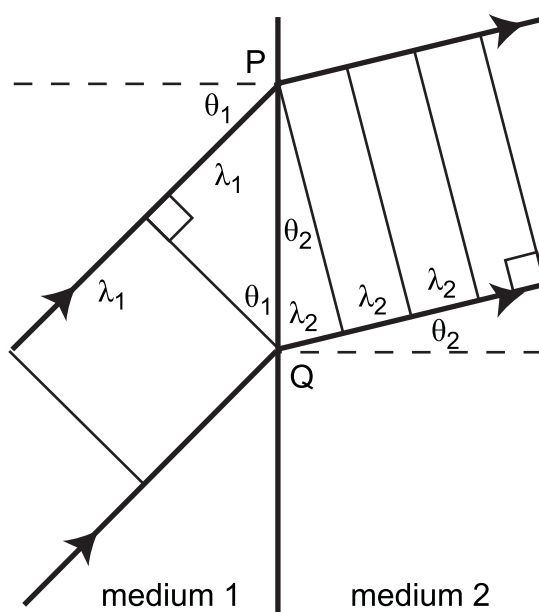

From the geometry of the diagram, we have:

$$\begin{aligned}\sin \theta_1 &= \frac{\lambda_1}{PQ} \\ \text{and } \sin \theta_2 &= \frac{\lambda_2}{PQ} \\ \therefore \frac{\sin \theta_1}{\sin \theta_2} &= \frac{\lambda_1}{PQ} / \frac{\lambda_2}{PQ} \\ \therefore \frac{\sin \theta_1}{\sin \theta_2} &= \frac{\lambda_1}{\lambda_2}\end{aligned}$$

Using the wave equation $v = f\lambda$, and remembering that the frequency of the wave does not change when the wave is refracted, we have:

$$v_1 = f \lambda_1$$

and $v_2 = f \lambda_2$

$$\therefore \frac{v_1}{v_2} = \frac{f \lambda_1}{f \lambda_2}$$

$$\therefore \frac{v_1}{v_2} = \frac{\lambda_1}{\lambda_2}$$

These two relationships taken together give:

$$\frac{\sin \theta_1}{\sin \theta_2} = \frac{\lambda_1}{\lambda_2} = \frac{v_1}{v_2}$$

Refractive index: Questions (20 min)

Go online



Q2: Which of these statements about refractive index is/are *true*?

- i. The refractive index of a medium is given by $\frac{\sin \theta_{\text{medium}}}{\sin \theta_{\text{vacuum}}}$.
 - ii. The refractive index of a medium is a measure of the ability of the medium to change the speed of a beam of light.
 - iii. The refractive index of a medium is always greater than one.
- a) (i) only
 - b) (ii) only
 - c) (iii) only
 - d) (i) and (ii) only
 - e) (ii) and (iii) only

.....

Q3: The following diagram shows a ray of light refracting from water into air.

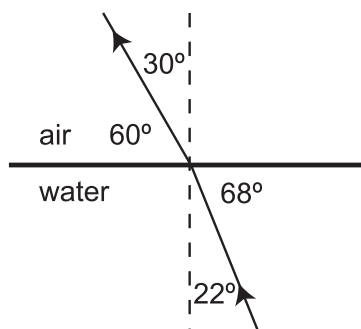

Which expression gives the refractive index of water?

- a) $\frac{\sin 60^\circ}{\sin 68^\circ}$
- b) $\frac{\sin 30^\circ}{\sin 22^\circ}$
- c) $\frac{\sin 22^\circ}{\sin 30^\circ}$
- d) $\frac{\sin 68^\circ}{\sin 60^\circ}$
- e) $\frac{\sin 68^\circ}{\sin 22^\circ}$

.....

Q4: The diagram shows a ray of light refracting from air into glass.

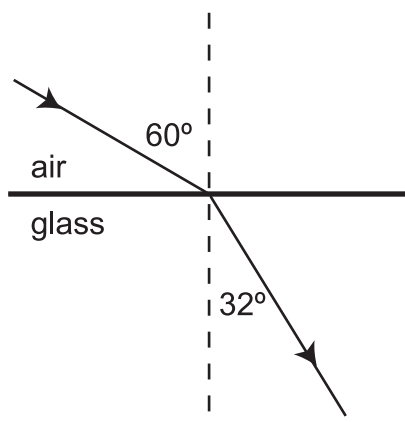

What is the refractive index of the glass used?

- a) 0.612
 - b) 1.06
 - c) 1.63
 - d) 1.70
 - e) 2.77
-

Q5: A light wave refracts from air into a glass block.

Which of the following quantities for the wave does *not* change on refraction?

- i. frequency
 - ii. wavelength
 - iii. speed
- a) (i) only
 - b) (ii) only
 - c) (iii) only
 - d) (i) and (ii) only
 - e) (ii) and (iii) only
-

Q6: A ray of light of wavelength 600 nm, travelling at $3.00 \times 10^8 \text{ m s}^{-1}$ in air, refracts into a perspex block. The refractive index of the perspex is 1.50.

What is the wavelength and the speed of the light in the perspex?

- a) wavelength 900 nm; speed $3.00 \times 10^8 \text{ m s}^{-1}$
- b) wavelength 900 nm; speed $2.00 \times 10^8 \text{ m s}^{-1}$
- c) wavelength 600 nm; speed $3.00 \times 10^8 \text{ m s}^{-1}$
- d) wavelength 400 nm; speed $2.00 \times 10^8 \text{ m s}^{-1}$
- e) wavelength 400 nm; speed $3.00 \times 10^8 \text{ m s}^{-1}$

6.1.3 Dispersion of laser beams

In this higher physics course, laser beams are assumed to be monochromatic. This means they contain waves of only one wavelength, one frequency and one colour.

However, in real life, laser beams are not monochromatic. In practice nearly all lasers contain a range of frequencies of light. This range can be quite narrow but there is nearly always some variation in frequency in the laser beam. Recent developments in laser technology have led to lasers that can be tuned, that is their frequency can be controlled.

When a high powered laser passes through glass such as a lens it causes the glass to increase in temperature. This lowers the refractive index of the centre of the lens causing the laser beam to undergo dispersion.

6.2 Total internal reflection and critical angle

We have already seen that when a ray of light travels from air into glass, its direction is changed to be closer towards the normal at the point of incidence. Since rays of light obey the **principle of reversibility**, it follows that when a ray of light travels from glass into air, its direction will be changed to be further away from the normal at the point of incidence. This can be shown using the same semi-circular glass block that was used earlier, only this time with the ray of light directed at the semi-circular face.

If the ray of light is directed towards the centre of the flat face of the block (i.e. along a radius of the semi-circle) its direction does not change when it enters the block. This is shown below.

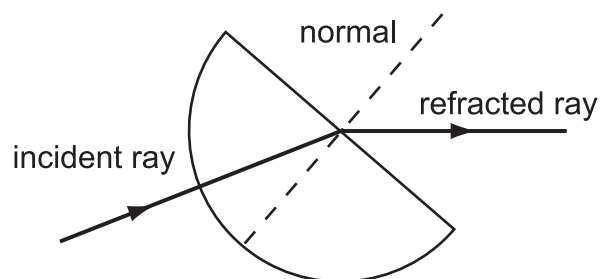

Refraction from glass into air

Because the angle of refraction in the air is always greater than the angle of incidence in the glass, there is a maximum angle of incidence that allows the ray to refract out of the glass. The following activity is designed to let you see the effect of altering the angle in the glass, and to measure this maximum angle. The activity also allows you to observe what happens when the maximum angle for refraction is exceeded.

Total internal reflection (15 min)

Go online



The apparatus shown below was set up.

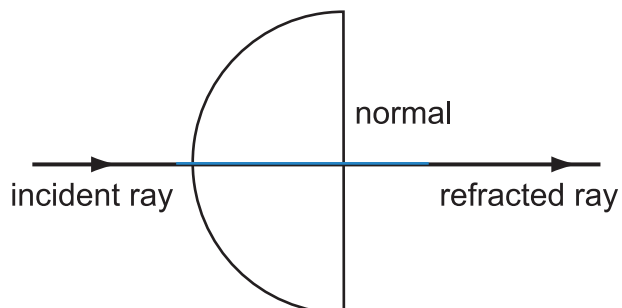

The angle in air is increased.

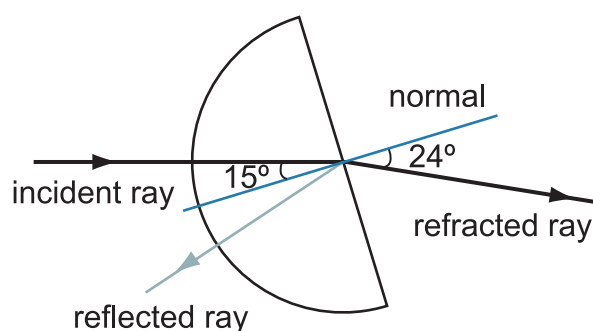

We can see that most of the light is refracted out of the glass into the air but there is some light reflected inside the glass.

The angle is increased further.

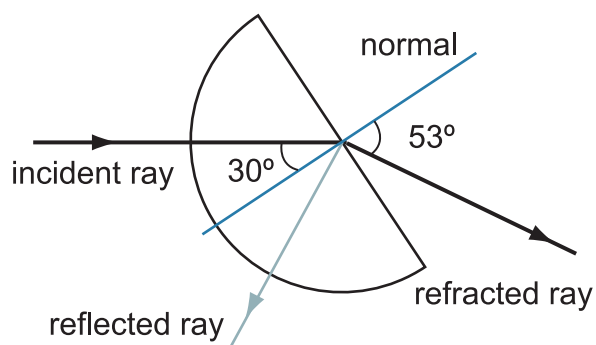

As the angle in glass is increased more light is reflected and less is refracted.

The angle is again increased.

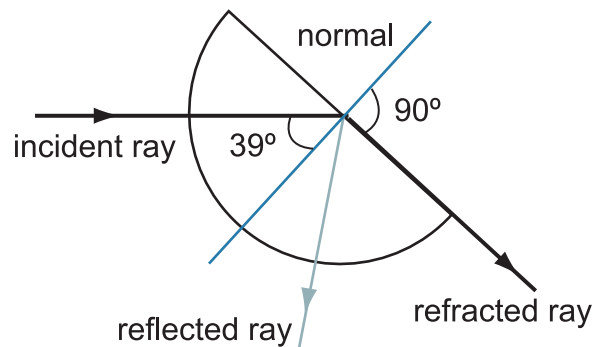

We can see that the light is now being refracted at 90° to the normal.

This is the maximum angle in the glass that light will be refracted. This is called the critical angle of the substance.

If the angle is again increased no light can be refracted out of the glass. All of the light is reflected inside the glass.

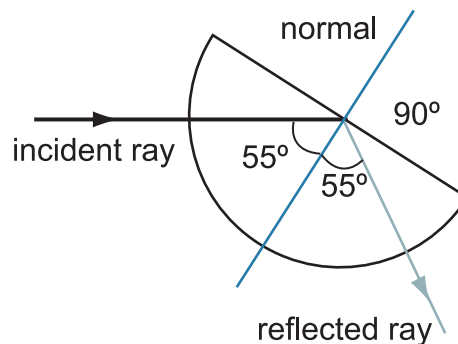

This is called total internal reflection.

The simulation should have shown you that when the angle between the normal and the ray in the glass, θ_{glass} , is below a certain critical value, the ray of light refracts out of the glass. As well as a refracted ray, there is also a reflected ray inside the glass. The reflected ray increases in brightness as θ_{glass} increases.

For one particular value of θ_{glass} (39° in the case of the simulation) the angle of refraction becomes 90° . This maximum value of θ_{glass} for which refraction can occur is known as the **critical angle** (θ_C).

When the angle between the normal and the ray in the glass, θ_{glass} , is greater than the critical angle the ray of light does not refract but is reflected inside the glass block at the plane face. This property is known as **total internal reflection**.

There is a relationship between the critical angle θ_C and the absolute refractive index of a medium, n . The following activity shows the derivation of this relationship.

Example : Critical angle for diamond

The refractive index, n_{diamond} , of diamond is 2.42.
Calculate the critical angle for diamond.

Answer:

$$\begin{aligned}\sin \theta_C &= \frac{1}{n_{\text{medium}}} \\ \therefore \sin \theta_C &= \frac{1}{n_{\text{diamond}}} \\ \therefore \sin \theta_C &= \frac{1}{2.42} \\ \therefore \sin \theta_C &= 0.413 \\ \therefore \theta_C &= 24.4^\circ\end{aligned}$$

Critical angle and absolute refractive index (5 min)

We have seen already that $\frac{\sin \theta_{\text{vacuum or air}}}{\sin \theta_{\text{medium}}} = n_{\text{medium}}$, so:

$$n_{\text{medium}} = \frac{\sin \theta_{\text{air}}}{\sin \theta_{\text{medium}}}$$

The maximum value of θ_{air} is 90° , so the maximum value of $\sin \theta_{\text{air}}$ is $\sin 90^\circ = 1$.
Putting this value into the above equation, we have:

$$n_{\text{medium}} = \frac{1}{\sin \theta_{\text{medium}}}$$

The maximum value of θ_{medium} for which refraction can occur is known as the critical angle, θ_C for the medium, so:

$$\begin{aligned}n_{\text{medium}} &= \frac{1}{\sin \theta_C} \\ \therefore \sin \theta_C &= \frac{1}{n_{\text{medium}}}\end{aligned}$$

6.3 Applications of total internal reflection

The total internal reflection of light has many applications. You will already be familiar with the use of optical fibres for the transmission of information by means of laser light. Optical fibres are used for communication, in medical instruments such as the endoscope and to connect sensors to displays. One of the major benefits of using optical fibres instead of copper cables in applications such as those mentioned, is that they do not carry electrical signals and so they do not suffer from electrical interference. They can also be used in hazardous situations where electrical sparks could be dangerous.

When optical fibres are used for communication, a modulated laser beam is sent along the fibre. Radiation in the visible or the infrared range can be used. As with all design considerations, there is a compromise to be achieved. If the frequency of the radiation is increased, then the rate at which information can be transmitted increases. However higher frequency radiation is also attenuated (cut down) more than radiation of lower frequencies as it travels through the optical fibres.

Total internal reflection is also used in the materials that car number plates and some reflective road signs are made from. This material consists of a plastic base coat with thousands of tiny (about 0.1 mm in diameter) glass spheres embedded in it. Light shining on to the glass spheres is refracted, totally internally reflected, and then refracted again. This results in the light that emerges from each of the spheres being parallel to the incident beam. Because of the way the spheres are arranged in a single flat layer, the overall effect is to reflect incident light back in the original direction. Reflective safety bands on clothing are also made of this material. A recent development in reflective road sign technology is to move from using the tiny glass beads to using a thin film containing tiny prisms. The prisms scatter the light less than the spheres so more light is reflected parallel to the incoming beam making the road sign appear brighter. This is particularly useful for signs that have to appear bright and be read from a distance and so are used widely on signposts on motorways.

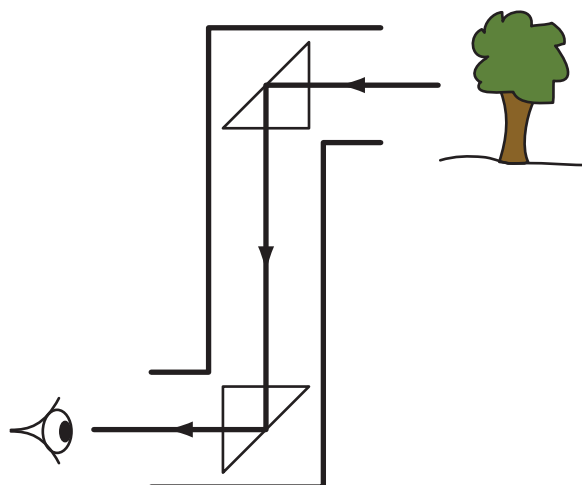

Many optical instruments, such as periscopes, single lens reflex (SLR) cameras and binoculars, make use of the total internal reflection of light within prisms. Two 45° - 45° - 90° prisms are used in a periscope, as shown in Figure 6.2. Used in this way, each prism turns the ray of light through 90° . One advantage that the prism periscope has over a periscope that uses the reflections at two mirrors is that there is *total* internal reflection at a prism, whereas only about 90% of a ray of light is reflected at each mirror. Also, with back-silvered mirrors, each mirror gives rise to two reflections (one from the top surface of the glass and one from the silvered back), causing four images, each slightly displaced from the others, to be seen by the viewer.

Figure 6.2: Prisms used in a periscope

A pair of binoculars consists essentially of two telescopes. To prevent the physical length of the instrument becoming too long, while maintaining a suitable magnification, each optical path is 'bent' by passing the light through two 45° - 45° - 90° prisms arranged at right angles to each other. The light follows the path shown in Figure 6.3 through each prism. Each prism bends the ray of light through 180° . In this way, the direction of the light ray is unaltered, although there is lateral displacement of the ray. Such a prism is sometimes called a Porro prism.

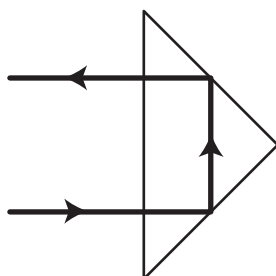
Figure 6.3: Prism used in binoculars (Porro prism)

Total internal reflection and critical angle: Questions (20 min)

Go online



Q7: What is the relationship between the critical angle, θ_C , and the absolute refractive index of a medium, n_{medium} ?

- a) $\theta_C = n_{\text{medium}}$
- b) $\theta_C = \frac{1}{n_{\text{medium}}}$
- c) $\sin \theta_C = n_{\text{medium}}$
- d) $\sin \theta_C = \frac{1}{n_{\text{medium}}}$
- e) $\sin^{-1} \theta_C = \frac{1}{n_{\text{medium}}}$

.....

Q8: A 'light guide' is made from a perspex rod. The perspex has a refractive index of 1.50. What is the critical angle of the perspex?

- a) 2.62°
- b) 3.47°
- c) 41.8°
- d) 48.2°
- e) 56.3°

.....

Q9: The critical angle for light emerging from ice into air is 50° . What is the refractive index of ice?

- a) 1.13
- b) 1.19
- c) 1.31
- d) 1.56
- e) 2.00

.....

Q10: Which of the following does *not* make use of total internal reflection?

- a) an endoscope
- b) an achromatic doublet lens
- c) an optical fibre communication link
- d) a single lens reflex camera
- e) reflective road signs

.....

Q11: Each half of a pair of binoculars uses 2, 45° - 45° - 90° prisms.

The *overall* effect of these prisms on a ray of light is to

- a) leave its direction unchanged but displace it sideways.
- b) change its direction by 180° and displace it sideways.
- c) change its direction by 90° and displace it sideways.
- d) change its direction by 180° but not displace it.
- e) leave its direction unchanged and not displace it.

6.4 Summary

Summary

You should now be able to:

- state that refraction is caused by light changing velocity when it enters a new medium;
- explain that the ratio $\frac{\sin \theta_1}{\sin \theta_2}$ is a constant when light passes obliquely from medium 1 to medium 2;
- explain that the absolute refractive index, n , of a medium is the ratio $\frac{\sin \theta_1}{\sin \theta_2}$, where θ_1 is in a vacuum (or air) and θ_2 is in the medium;
- describe the principles of a method for measuring the absolute refractive index of glass for monochromatic light;
- carry out calculations using the relationship for refractive index, $\frac{\sin \theta_{\text{vacuum or air}}}{\sin \theta_{\text{medium}}} = n_{\text{medium}}$;
- explain that the refractive index depends on the frequency of the incident light;
- explain that the frequency of a wave is unaltered by a change in medium;
- explain the relationships $\frac{\sin \theta_1}{\sin \theta_2} = \frac{\lambda_1}{\lambda_2} = \frac{v_1}{v_2}$ for refraction of a wave from medium 1 to medium 2;
- carry out calculations using the relationships $\frac{\sin \theta_1}{\sin \theta_2} = \frac{\lambda_1}{\lambda_2} = \frac{v_1}{v_2}$;
- explain what is meant by total internal reflection;
- explain what is meant by critical angle θ_C ;
- describe the principles of a method for measuring a critical angle;
- derive the relationship $\sin \theta_C = 1/n$ where θ_C is the critical angle for a medium of absolute refractive index n ;
- carry out calculations using the relationship $\sin \theta_C = 1/n$.

6.5 Extended information

Top tip

Links

The authors do not maintain these web links and no guarantee can be given as to their effectiveness at a particular date.

They should serve as an insight into the wealth of information available online and encourage you to explore the subject further.

- University of Colorado: A flexible interactive simulation on refraction of light and critical angle.
<http://phet.colorado.edu/en/simulation/bending-light>
- Freezeray.com: This site contains a number of simple animations showing refraction and total internal reflection of light.
<http://phet.colorado.edu/en/simulation/bending-light>
- Interactagram.com: Clearly simulates total internal reflection occurring beyond the critical angle.
<http://interactagram.com/physics/optics/refraction/>
- HyperPhysics, Georgia State University: An alternative text on refraction of light.
<http://hyperphysics.phy-astr.gsu.edu/hbase/geoopt/refr2.html#c1>

6.6 Assessment

End of topic 6 test

Go online



The following test contains questions covering the work from this topic.



The following data should be used when required:

Speed of light $c = 3.0 \times 10^8 \text{ m s}^{-1}$

Q12: A ray of white light passes from air into perspex as shown.

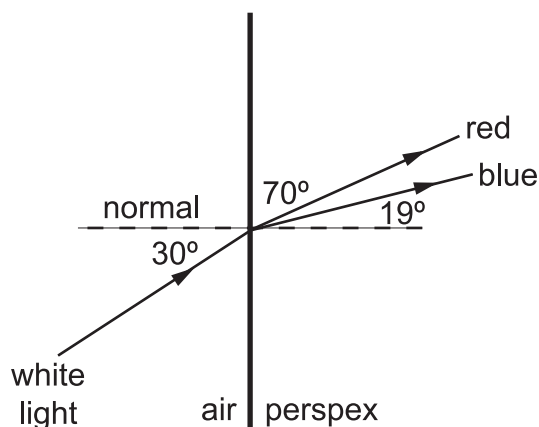

What is the angle of refraction for the red light in the perspex?

- a) 1°
- b) 19°
- c) 20°
- d) 30°

.....

Q13: The diagram shows the refraction of a ray of monochromatic light of frequency $4.8 \times 10^{14} \text{ Hz}$, as it passes from water into air.

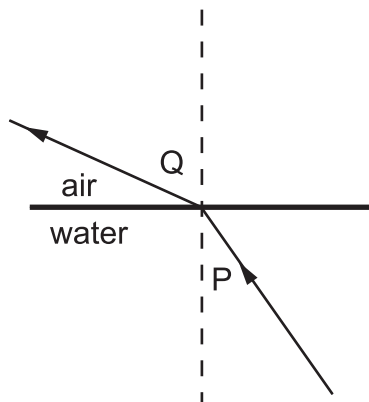

The ray makes an angle of 45° to the normal in the water. (The diagram is not drawn to scale.)

The refractive index of water for the light used is 1.33.

- a) Calculate angle Q in degrees. (Give your answer to the nearest degree.)
- b) Calculate the critical angle in degrees for the light in the water. (Give your answer to the nearest degree.)
- c) Calculate the wavelength of the light in air. (Give your answer in nm.)
- d) Calculate the wavelength of the light in the water. (Give your answer in nm.)
- e) What is the frequency, in $\times 10^{14}$ Hz, of the light in the water?

.....

Q14: A parallel ray of monochromatic light in air meets a plane glass surface obliquely. In the glass, the ray

- A) follows a curved path.
- B) remains parallel.
- C) undergoes dispersion.
- D) diverges.
- E) converges.

.....

Q15: A ray of monochromatic light is sent from air into a glass rod as shown.

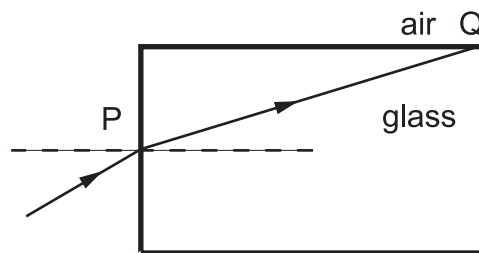

The refractive index of the glass for the light used is 1.71.

- a) Calculate the greatest angle in degrees of refraction at P. (Give your answer to the nearest degree.)
- b) Explain what happens to the ray at Q.
 - A) The ray undergoes total internal reflection at Q because the angle of incidence in the glass is greater than the critical angle.
 - B) The ray refracts out of the glass rod at Q because the angle of incidence in the glass is less than the critical angle.
 - C) The ray undergoes total internal reflection at Q because the angle of incidence in the glass is less than the critical angle.
 - D) The ray undergoes total internal reflection at Q because the angle of incidence in the glass is equal to the critical angle.
 - E) The ray refracts out of the glass rod at Q because the angle of incidence in the glass is greater than the critical angle.

.....

Q16: A ray of monochromatic light follows the path shown through a triangular prism.

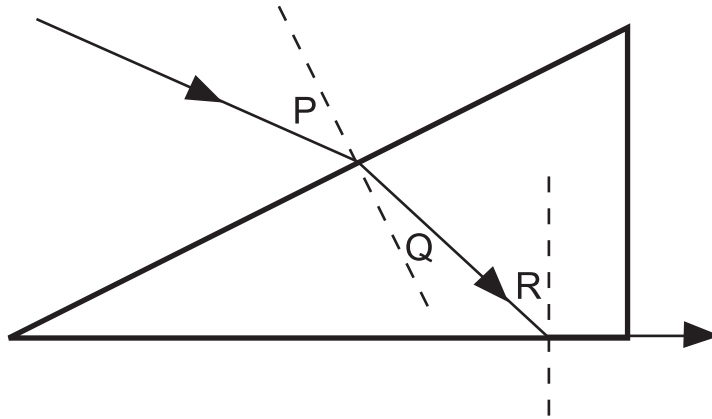

Angle P is 31° and angle Q is 17° .

Calculate angle R in degrees. (Give your answer to the nearest degree.)

Topic 7

Spectra

Contents

7.1 Irradiance	134
7.1.1 Irradiance of a point source	136
7.2 Spectra	140
7.2.1 Energy levels	140
7.2.2 Spectra explained	141
7.3 Summary	149
7.4 Extended information	150
7.5 Assessment	150

Learning objective

By the end of this topic you should be able to:

- define the term irradiance;
 - carry out calculations based on the relationship between irradiance, power and surface area;
 - describe a method to show the relationship between irradiance and distance;
 - carry out calculations involving the above relationship;
 - describe the Bohr model of the atom;
 - explain atomic energy levels and show how these can be represented on a diagram;
 - correctly use the terms: ground state, excited state, ionisation and zero potential energy in the context of the Bohr model of the atom;
 - explain the formation of line, continuous and absorption spectra in terms of the movement of electron between atomic energy levels;
 - explain the dependence of photon frequency on the energy difference between levels;
 - explain the production of absorption lines in the spectrum of sunlight and its significance as evidence for the composition of the Sun's upper atmosphere.
-

In this topic we will examine some aspects of light that we have not looked at so far.

We start the topic by defining the term irradiance in relation to electromagnetic radiation. We then go on to examine the production of line spectra (both emission and absorption).

7.1 Irradiance

Definition

When radiation hits a surface at right angles, the **irradiance** at the surface is defined as the power per unit area. This can be written in the form of Equation 7.1

$$I = \frac{P}{A} \quad (7.1)$$

Power (P) is measured in watts; area (A) is measured in square metres and irradiance (I) is measured in watts per square metre (W m^{-2}).

Note that when using Equation 7.1 we must only use the surface area actually hit by the radiation.

Example : Irradiance calculations

A torch is shone on a wall 3 m wide by 2 m high. The torch produces a circle of light of radius 10 cm and the power of the light at the wall is measured to be 3 mW. Calculate the irradiance of the light at the wall.

Answer:

$$\text{Area of circle} = \pi r^2$$

$$= 3.14 \times 0.1^2$$

$$= 3.14 \times 10^{-2} \text{ m}^2$$

$$\text{Power} = 3 \times 10^{-3} \text{ W}$$

$$I = \frac{P}{A}$$

$$= \frac{3 \times 10^{-3}}{3.14 \times 10^{-2}}$$

$$= 0.1 \text{ W m}^{-2}$$

Irradiance calculations: Questions (20 min)

Go online



Q1: The power of light hitting a 10 cm^2 area is measured to be 100 mW. What is the irradiance of light hitting the area?

- a) 0.01 W m^{-2}
- b) 0.1 W m^{-2}
- c) 1 W m^{-2}
- d) 10 W m^{-2}
- e) 100 W m^{-2}

.....

Q2: The irradiance of light hitting a solar panel measuring 2 m x 5 m is found, on average, to be 80 W m^{-2} over a one hour period. How much energy is received by the panel during that period?

- a) 480 J
- b) 800 J
- c) 28.8 kJ
- d) 48.0 kJ
- e) 2.88 MJ

.....

Q3: A 2 m^2 solar panel receives 300 kJ over a 20 minute period. What was the average irradiance of the sunlight during this time?

- a) 0.125 W m^{-2}
- b) 7.5 W m^{-2}
- c) 125 W m^{-2}
- d) $7\,500 \text{ W m}^{-2}$
- e) $180\,000 \text{ W m}^{-2}$

.....

Q4: A 500 W spotlight produces a circle of light of diameter 4 m on a theatre stage. Assuming no energy losses, what is the irradiance of the light at the stage?

- a) 125 W m^{-2}
- b) 80 W m^{-2}
- c) 40 W m^{-2}
- d) 31 W m^{-2}
- e) 10 W m^{-2}

.....

Q5: A laser light produces a spot of light of irradiance 125 W m^{-2} . If the spot has diameter of 1 mm and assuming no energy losses, what is the power output of the laser?

- a) 0.1 mW
- b) 40 W
- c) 159 W
- d) 393 W
- e) 98 MW

7.1.1 Irradiance of a point source

This section deals with the irradiance of a light source but it applies equally well to any other point source of radiation. An ideal point source is one which is infinitesimally small and radiates with equal irradiance in all directions. In practice no such source exists since even an atom has size but objects as large as stars can be considered as point sources at distances large in comparison to their radius. Point sources produce an expanding sphere of radiation.

It is important when dealing with light sources to realise that irradiance is not the same thing as brightness. The brightness of a light source relates to how the human eye reacts to light. As you know, visible light ranges from red through to violet, but our eyes react to the middle of the spectrum more than the ends. For this reason green and yellow appear brighter than red or blue. As we move further away from a light source it may seem to be smaller and less bright but its true size and actual brightness do not change. However there must be a link between distance and the effect it has on our eyes since we could suffer eye damage from a small glance at the sun yet we can easily look at larger and more powerful stars in the night sky. The reason for this is that the irradiance of light entering our eyes is different.

Let's consider a simple case: suppose we have a point source of light that has a constant power of 100 W. This source produces an expanding sphere of light and as we move further from the source the surface area of the sphere becomes larger. The irradiance is the power per unit area and as the power is constant, the irradiance must decrease with distance as it is spread over a larger area.

Irradiance and distance investigation (10 min)

Go online



The apparatus shown below is set up.

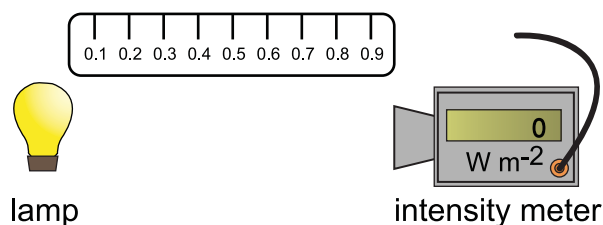

We can see that at this distance from the lamp the irradiance is 8 W m^{-2} .

The meter is now moved closer to the lamp and the meter reading taken again. When the meter is 0.9 metres from the lamp the reading is 10 W m^{-2} .

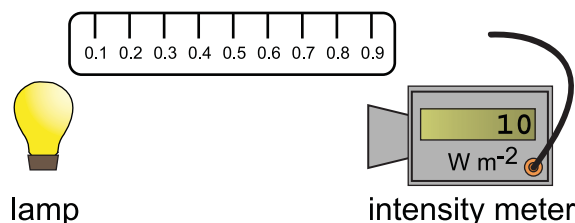

The experiment is repeated for decreasing distances and the reading on the meter noted at each distance.

A graph of the irradiance I of a 100 W point source against distance (d) produces a curved line as shown in Figure 7.1.

Figure 7.1: Irradiance against distance

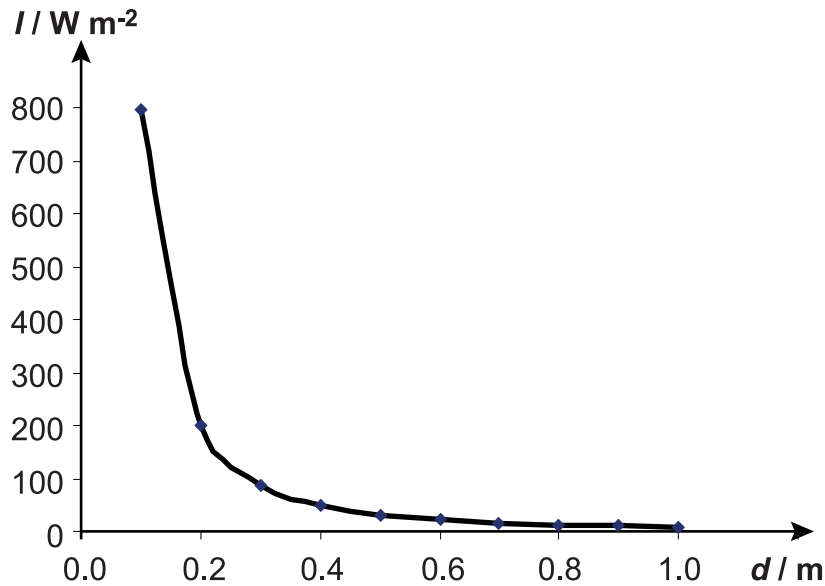

If we then draw a graph of irradiance against $1/d^2$ we obtain a straight line (Figure 7.2) through the origin, which shows that irradiance is inversely proportional to the square of the distance.

Figure 7.2: Irradiance against $1/\text{distance}^2$

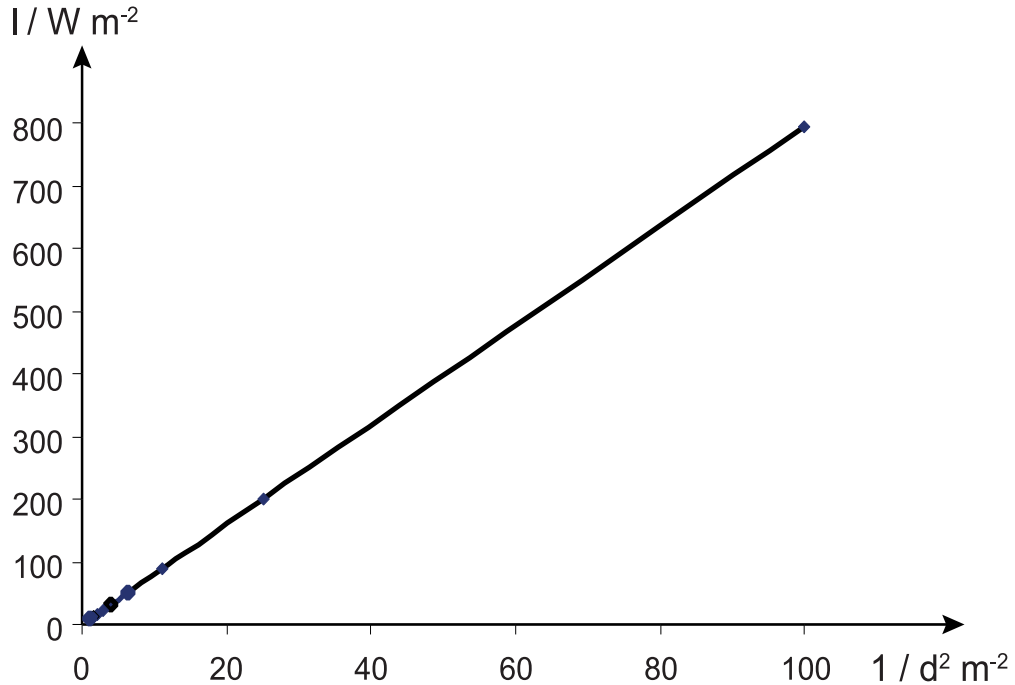

The irradiance of radiation from a point source is inversely proportional to the square of the distance from the source.

This leads us to Equation 7.2:

$$I \propto \frac{1}{d^2}$$

$$\therefore I = \frac{k}{d^2}$$

$$\therefore Id^2 = k$$

$$I_1 d_1^2 = I_2 d_2^2 \tag{7.2}$$

We already know that the irradiance of a source decreases with distance but this equation allows us to calculate by how much. In the following example we will show the effect of doubling the distance.

Example : Irradiance and distance

Suppose that a source has irradiance I_1 at a distance d_1 . What is its irradiance I_2 at a distance d_2 where $d_2 = 2 \times d_1$?

Answer:

$$I_1 d_1^2 = I_2 d_2^2$$

$$I_1 d_1^2 = I_2 (2d_1)^2$$

$$I_1 d_1^2 = 4I_2 d_1^2$$

$$I_1 = 4I_2$$

$$I_2 = \frac{I_1}{4}$$

So doubling the distance from a point source cuts the irradiance by a factor of four.

To explain this we need to consider the surface area of a sphere, which is equal to $4\pi r^2$. You may like to verify for yourself that doubling the radius of the sphere increases the surface area by a factor of four. If the power of the source is constant then Equation 7.1 tells us that the irradiance will be quartered.

If we know the irradiance of a point source at one particular distance then we can calculate the irradiance at any other distance using Equation 7.2.

It is important to realise that Equation 7.2 can only be used if we are dealing with a point source. A laser cannot be considered as such since laser light remains as a very narrow beam even over quite long distances. The irradiance of laser light remains approximately constant over short distances.

We can use irradiance to confirm Hubble's law. There are certain stellar objects that are called 'standard candles'. These are objects with a known constant brightness. By measuring their irradiance at the Earth we can calculate their distance from us using the inverse square law. This is one of methods used to confirm Hubble's law.

Inverse square law: Questions (15 min)

Go online



Q6: The irradiance of a point source of light is measured to be 32 W m^{-2} at a distance of 2 m. What is the irradiance at 8 m?

- a) 16 W m^{-2}
- b) 8 W m^{-2}
- c) 4 W m^{-2}
- d) 2 W m^{-2}
- e) 1 W m^{-2}

.....

Q7: The irradiance of a point source of light is measured to be 2.5 W m^{-2} at a distance of 12 m. What is the irradiance at 3 m?

- a) 0.625 W m^{-2}
- b) 1.25 W m^{-2}
- c) 5 W m^{-2}
- d) 10 W m^{-2}
- e) 40 W m^{-2}

.....

Q8: The irradiance of a point source of light is measured to be 2 W m^{-2} by an observer at a distance of 140 cm. Another observer measures it to be 3 W m^{-2} . How far is the second observer from the source?

- a) 70 cm
- b) 93 cm
- c) 114 cm
- d) 131 cm
- e) 280 cm

.....

Q9: The power of a point source of light is measured to be 2 W spread over an area of 0.1 m^2 at a distance of 5 m. What is the irradiance of the light at 2 m?

- a) 12.5 W m^{-2}
- b) 20 W m^{-2}
- c) 50 W m^{-2}
- d) 125 W m^{-2}
- e) 1250 W m^{-2}

.....

Q10: The irradiance of a laser beam is measured as 140 W m^{-2} at a distance of 50 cm. What is the irradiance at 2 m?

- a) 35 W m^{-2}
- b) 70 W m^{-2}
- c) 140 W m^{-2}
- d) 280 W m^{-2}
- e) 560 W m^{-2}

7.2 Spectra

In this section we will look at the internal structure of the atom and show how this can be used to explain radiation spectra.

7.2.1 Energy levels

We saw in a previous topic that a photon of light with sufficient energy can knock an electron out of a metal and that the kinetic energy of the electron is equal to the difference between the photon's energy and the energy needed to remove it from the metal.

We now ask two questions:

1. What happens to the electron if its kinetic energy is zero?
2. What happens if a photon does not have enough energy to remove the electron?

If the electron gains just enough energy to break free from the atom then it will have no excess kinetic energy and will be stationary next to the atom, which now has a positive charge. In all probability the electron will be attracted back inside the atom but what happens to the energy that it absorbed from the photon? In order to fall back into the atom the electron must give out the energy it absorbed and it does this by releasing another photon.

Even if a photon does not have enough energy to ionise an atom it can still pass it on to an electron, which effectively stores the energy until the electron releases it again in the form of a new photon. What is strange about this process is that, for any particular element, only photons of certain frequencies can be absorbed. It seems that electrons can only have certain discrete amounts of energy within an atom.

To help us visualise this situation we can produce an energy level diagram as shown in Figure 7.3. The lowest line in the diagram represents the lowest energy that an electron can have and is called the **ground state**. Electrons on higher levels are said to be in an **excited state** and the top line represents the **ionisation level** of the atom. Notice that the energy levels get closer together the further they are from the ground state. As stated earlier an electron that gains just enough energy to reach the ionisation level will have zero kinetic energy. If it falls back into the atom it will emit energy in the form of a photon. For that reason the energy levels are given negative values. The value refers to the energy an electron must gain to reach the ionisation level. Every element has its own unique energy level diagram and the energies shown in Figure 7.3 refer to an atom of hydrogen.

Figure 7.3: Energy level diagram

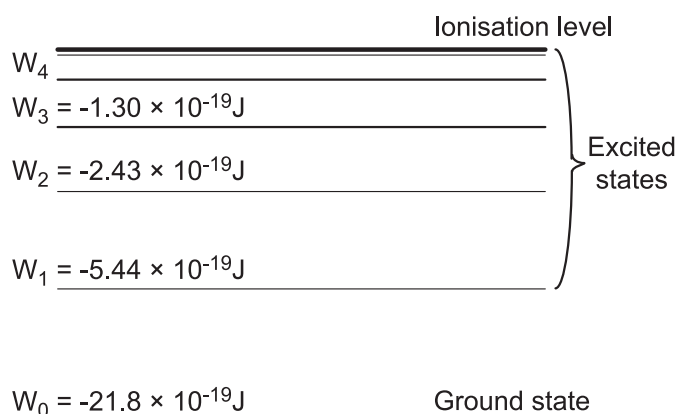

We will look at the evidence for energy levels in atoms in the next section.

7.2.2 Spectra explained

Sir Isaac Newton showed that white light could be split into the colours of the rainbow. This is known as a continuous spectrum since all the colours merge into each other.



However, if we look at the spectra of heated elements we get something quite different.

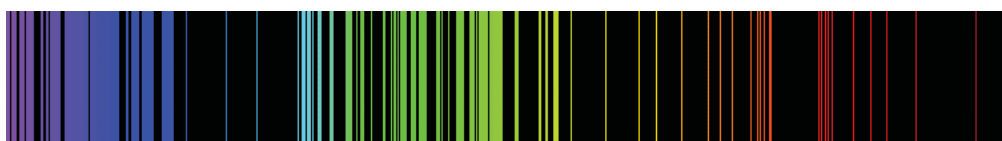

When elements are placed in a bunsen flame, the flame burns with a distinctive colour. If the element is in the form of a gas and electricity is passed through it, the gas glows with the same distinctive colour. The images below show the flames produced when sodium and lithium are heated in a flame.



Sodium heated in a flame (photo by Swm, licensed under CC BY-SA 3.0)

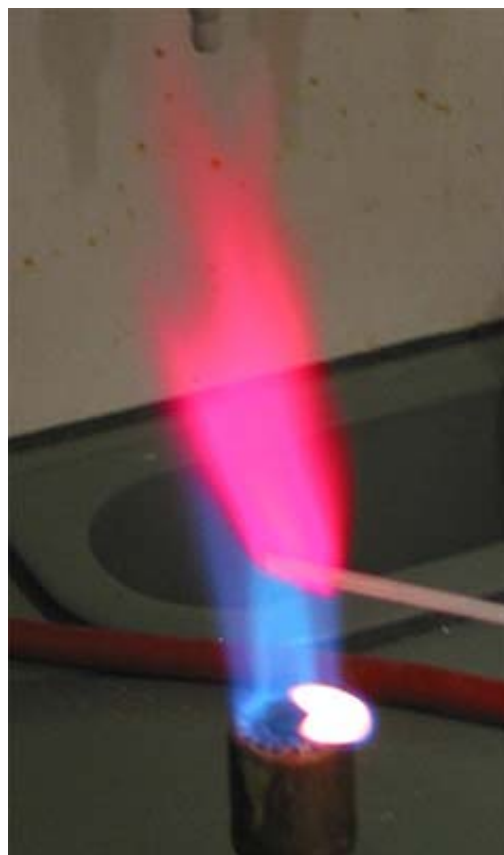

Lithium heated in a flame (photo by Herge for Wikimedia)

7.2.2.1 Line emission spectra

If we pass the light produced from heated elements through a prism, the spectra produced are quite different from the continuous spectrum of white light. Only certain colours are seen as thin lines separated by areas of darkness. Every element has its own unique set of spectral lines and this fact can be used to identify elements. Line emission spectra are like fingerprints of elements, allowing astronomers to establish what elements are present within a star. In fact helium was discovered on the Sun before it was found on Earth because of its spectral lines, which did not match any known element. The element was named after the Greek word for the sun: helios.

This type of spectrum is called a **line emission spectrum** and it is this that provides the evidence for the atomic energy levels mentioned in a previous section. When an electron jumps down to a lower level it loses energy in the form of a photon. Using the equation $E = hf$ we can relate this energy to a particular frequency of radiation, which in the case of visible light refers to a particular colour in the spectrum. If electrons were allowed to make any size of jump then every colour would be possible and the spectrum would be continuous. As we only get individual lines it must mean that certain jumps are just not allowed.

Figure 7.4: Line emission spectrum



In line spectra some lines appear more intense than others. This is due to some energy jumps being more likely than others. An electron that gains enough energy to jump from the ground state up to the third excitation level doesn't have to jump straight back down to the ground state; it could for instance jump to the second level and then to the ground state, or by any other possible route (Figure 7.5). The more electrons that take a particular jump the more intense the spectral line will appear.

Figure 7.5: Energy jumps

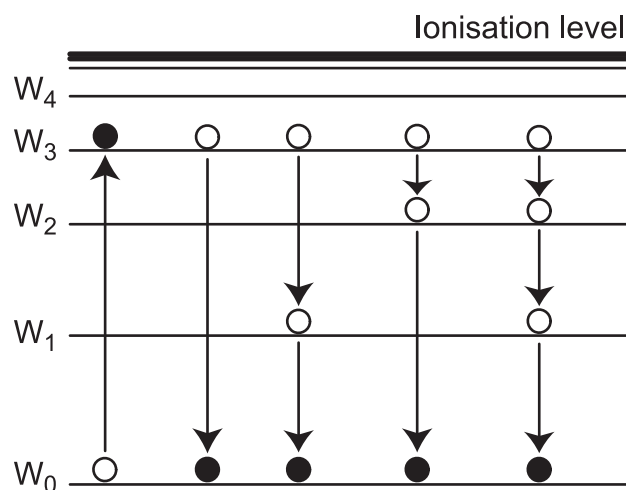

When an electron gains energy and moves to a higher energy level eg W_0 to W_2 , we say the electron has been "excited".

When the electron falls to a lower energy level eg W_3 to W_1 , we say the electron has "de-excited"

and a photon of energy will be released.

Each atom has a limited number of energy levels. This means there is a limited number of different de-excitations and therefore a limited number of different photon energies that can be released.

This effect is used in fluorescent lighting. The gas used in a fluorescent tube emits photons in the ultraviolet part of the spectrum, which is totally invisible to the human eye. The coating inside the glass tube absorbs the UV photons and the electrons jump to a high energy level. When the electrons return to the ground state, they do so in a series of steps and so the photons that they emit have less energy than the original ones and so appear as visible light.

Why should electrons, having reached an upper level, fall back down again? The reason is that atoms are at their most stable when all of their electrons are in their lowest possible levels and so electrons cannot stay in an excited state indefinitely. This does not mean that all the electrons eventually fall down to the ground state, as this level is only able to hold two electrons. When this is filled, a third electron must go into the first energy level above. Don't worry about this as we will only be dealing with the energy level diagram for hydrogen, which of course only has one electron.

In some materials the electrons can stay at a higher level for some time. This means that they can absorb energy from a light source and re-emit it after the original source is removed. It is this effect, called phosphorescence, that is used for glow-in-the-dark novelty toys.

7.2.2.2 Line absorption spectra

A close look at the spectrum of sunlight reveals that it is not completely continuous. In fact it has many hundreds of thin dark lines across its range. These are known as 'Fraunhofer lines' after Joseph Fraunhofer who made a careful study of them. The dark lines matched exactly the emission line spectra of known elements.

As you know, white light is made up of all the possible frequencies of visible light, which is why it produces a continuous spectrum. This means that white light contains photons of every possible energy within the visible range. If the spectrum of white light is viewed after having passed through a gas then it too has a series of dark lines across it. The lines match exactly the visible section of the emission spectrum of the elements that make up the gas. This is known as a **line absorption spectrum**.

Shown as follows is

1. the emission spectrum produced by a sodium lamp;
2. the absorption spectrum produced when white light is passed through a sodium lamp.

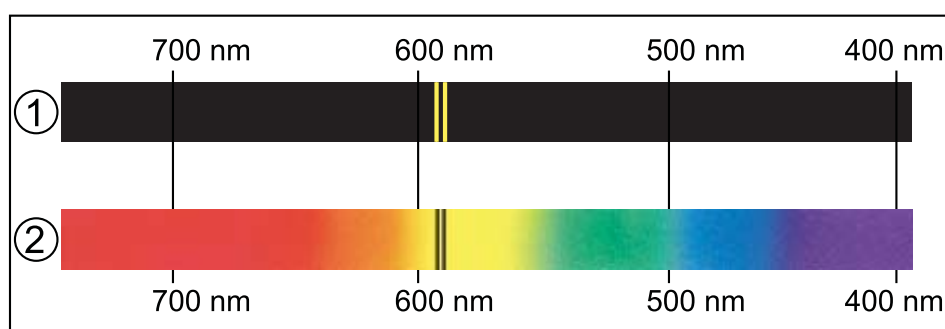

Emission spectrum (1) is produced when the light from a sodium lamp is viewed through a spectroscope.

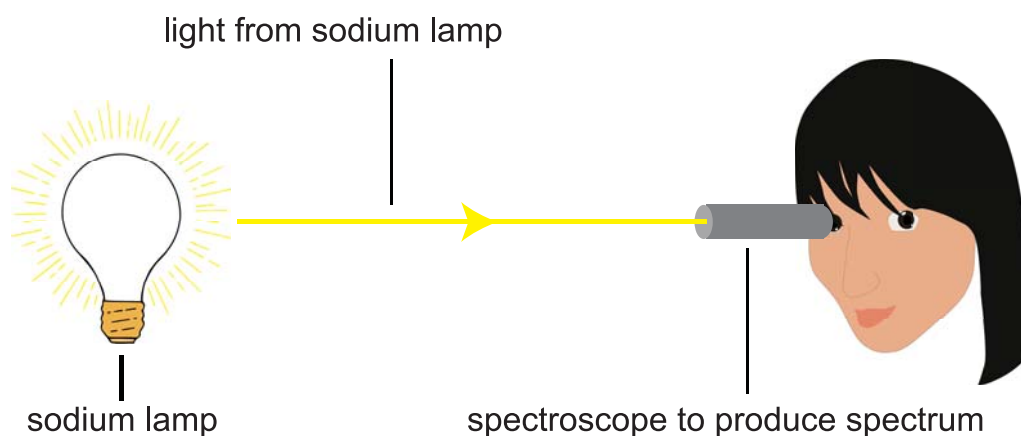

Absorption spectrum (2) is produced when white light from a lamp is passed through a sodium lamp and the light is viewed through a spectroscope.

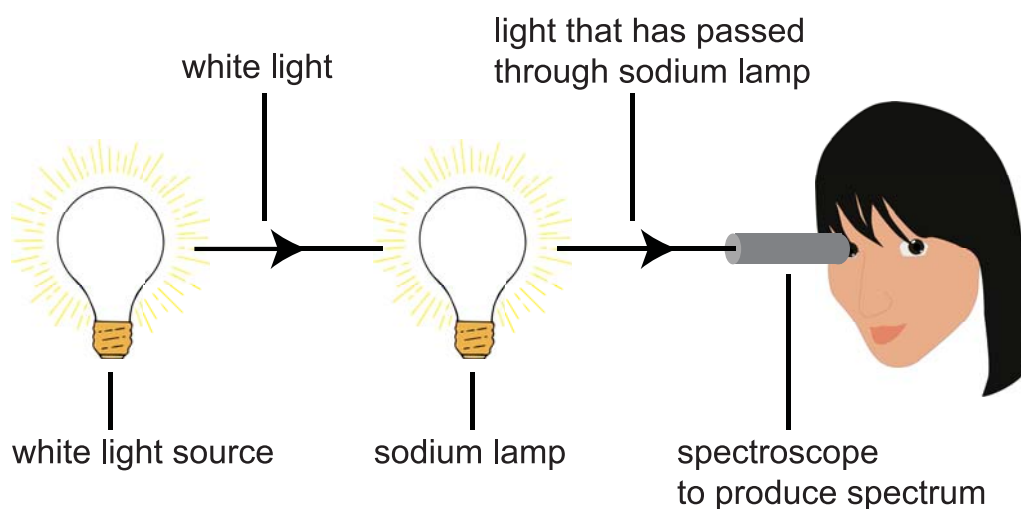

The reason of course is that the electrons within the atoms of the gas absorb the photons that have just the right amount of energy needed for a jump to a higher level. The electrons will eventually drop back down to the lower level again and release photons but the line will still appear black as the released photons can radiate in any direction and so only a very small amount will continue in the original direction.

Figure 7.6: Absorption and re-emission of photons

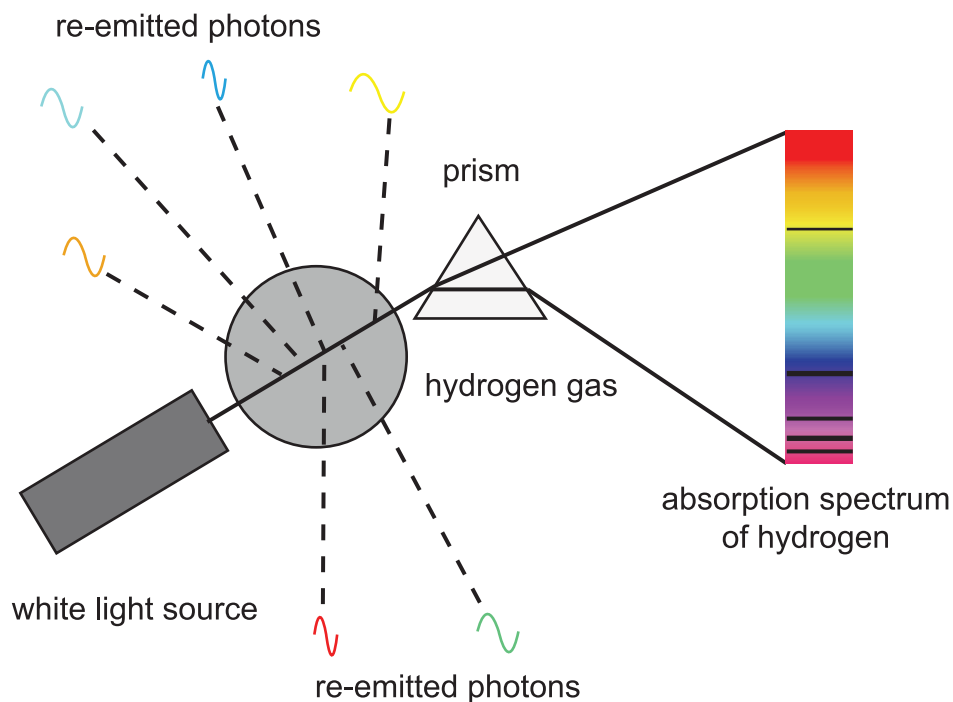

Can you see how this also applies to the dark lines seen in the Sun's spectrum? The outer layers of the Sun are cooler than the inner layers and so the gases there absorb some of the photons produced in the Sun's core. Like the gas absorbing some of the white light, the photons will eventually be released but they will radiate in many directions and again the lines will appear darker than the rest of the spectrum.

This method is also useful for identifying the gases in the atmosphere of a planet, which does not radiate its own light. The spectrum of the sunlight that passes through the atmosphere of the planet will be missing some lines corresponding to the elements in the atmosphere.

7.2.2.3 Energy level calculations

The study of line spectra is one way of calculating the energy levels of the elements. It is quite easy to see that the bigger the jump, the higher the energy of the photon produced. This of course means the higher the frequency of photon. Remember that only some of these frequencies will correspond to visible light and it is necessary to check within the infrared and ultraviolet sections of the spectrum to get a fuller picture.

Consider a line in an emission spectrum. It must be the result of an electron jumping from one level (W_2) to a lower level (W_1), although it does not mean that W_1 is the next level down from W_2 . This jump will emit a photon of energy (E) equal to $W_2 - W_1$ and since we also know that $E = hf$ we can state that in general:

$$W_2 - W_1 = hf$$

(7.3)

Equation 7.3 must also apply to a line in an absorption spectrum as it requires the absorption of the same amount of energy to jump up from W_1 to W_2 . If we know the value of W_1 and the frequency of the 'missing' line, we can calculate W_2 by expressing Equation 7.3 in the form:

$$W_2 = W_1 + hf$$

Example : Energy level calculations

Figure 7.7 shows some of the energy levels for hydrogen.

Figure 7.7: Hydrogen energy level diagram

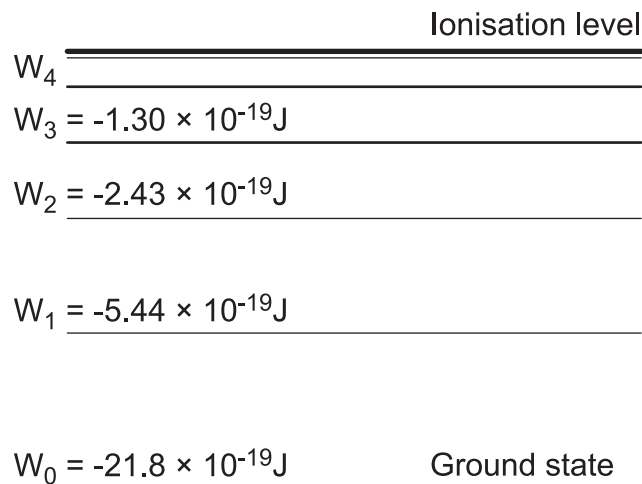

- Calculate the highest frequency emission line for the energy levels shown.
- Calculate the missing energy level if an electron in the ground state reaches it by absorbing a photon of frequency 3.15×10^{15} Hz.

Answer:

- The highest frequency spectral line corresponds to the largest energy jump i.e. from the ionisation level down to the ground state, which in this case is equal to 2.18×10^{-18} J.

$$E = hf$$

$$2.18 \times 10^{-18} = 6.63 \times 10^{-34} \times f$$

$$f = \frac{2.18 \times 10^{-18}}{6.63 \times 10^{-34}}$$

$$f = 3.29 \times 10^{15} \text{ Hz}$$

b)

$$W_4 = W_0 + hf$$

$$= -2.18 \times 10^{-18} + (6.63 \times 10^{-34} \times 3.15 \times 10^{15})$$

$$= -2.18 \times 10^{-18} + 2.09 \times 10^{-18}$$

$$= -0.09 \times 10^{-18}$$

$$= -0.9 \times 10^{-19} \text{ J}$$

Energy level calculations: Questions (20 min)

Go online



Data: Planck's constant $h = 6.63 \times 10^{-34} \text{ J s}$

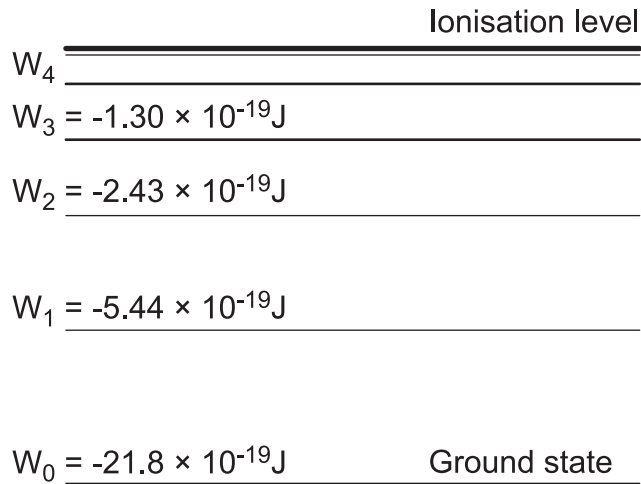

This quiz refers to the energy levels in a hydrogen atom.

Q11: How many emission lines could be produced by jumps between the four energy levels W_3 , W_2 , W_1 and W_0 of hydrogen?

- a) 3
- b) 4
- c) 6
- d) 8
- e) 12

.....

Q12: An electron jumps to a lower energy level in an atom releasing a photon of energy $3.01 \times 10^{-19} \text{ J}$. What is the frequency of the emitted photon?

- a) $1.99 \times 10^{-52} \text{ Hz}$
- b) $6.61 \times 10^{-7} \text{ Hz}$
- c) $1.51 \times 10^6 \text{ Hz}$
- d) $4.54 \times 10^{14} \text{ Hz}$
- e) $1.36 \times 10^{23} \text{ Hz}$

.....

Q13: Considering the energy level diagram for a hydrogen atom shown above, state the number of possible electron transitions which would release photons in the visible region of $4.3 \times 10^{14} \text{ Hz}$ to $7.5 \times 10^{14} \text{ Hz}$.

- a) 1
- b) 2
- c) 3
- d) 4
- e) 5

.....
Q14: What is the maximum wavelength of radiation that could ionise an electron in the ground state?

- a) 90 nm
- b) 91 nm
- c) 97 nm
- d) 1535 nm
- e) 1754 nm

.....
Q15: What would be the kinetic energy of an electron ionised from the ground state when illuminated with light of frequency 3.50×10^{15} Hz?

- a) 1.40×10^{-19} J
- b) 1.78×10^{-18} J
- c) 2.08×10^{-18} J
- d) 2.19×10^{-18} J
- e) 2.32×10^{-18} J

7.2.2.4 Continuous spectra

Line emission spectra really only apply to low pressure gases, where the atoms are far apart and do not interact with each other to any great extent. In other situations, such as hot solids or high pressure gases, the electrons are not confined to jumps within their own atom. It is possible for an electron to jump between atoms and so many more jumps are now possible. This results in many more possible frequencies and so the spectrum appears continuous.



Continuous spectrum

7.3 Summary

Summary

You should now be able to:

- explain that the irradiance I at a surface on which radiation is incident is the power per unit area;
- carry out calculations based on the relationship between irradiance, power and surface area;
- describe the principles of a method for showing that the irradiance is inversely proportional to the square of the distance from a point source;
- carry out calculations involving the relationship $I = k/d^2$;
- state that electrons in a free atom occupy discrete energy levels;
- draw a diagram which represents qualitatively the energy levels of a hydrogen atom;
- use the following terms correctly in context: ground state, excited state, ionisation and zero potential energy in the context of the Bohr model of the atom;
- explain that an emission line in a spectrum occurs when an electron makes a transition between an excited energy level W_2 and a lower level W_1 , where $W_2 - W_1 = hf$;
- explain that an absorption line in a spectrum occurs when an electron in energy level W_1 absorbs radiation of energy hf and is excited to energy level W_2 , where $W_2 = W_1 + hf$;
- explain the formation of line, continuous and absorption spectra in terms of the movement of electron between atomic energy levels;
- explain the occurrence of absorption lines in the spectrum of sunlight.

7.4 Extended information

Top tip

Links

The authors do not maintain these web links and no guarantee can be given as to their effectiveness at a particular date.

They should serve as an insight into the wealth of information available online and encourage you to explore the subject further.

- University of Nebraska: An interactive simulation of a inverse square law investigation.
<http://astro.unl.edu/classaction/animations/stellarprops/lightdetector.html>
- PCCL: An animation of various types of light passing through a prism.
http://www.physics-chemistry-interactive-flash-animation.com/optics_interactive/scattering_prism_spectrum_emission_absorption_white_monochromatic_light.htm
interactive/scattering_prism_spectrum_emission_absorption_white_monochromatic_light.htm
- Education Scotland: Alternative student notes.
<http://www.educationscotland.gov.uk/highersciences/physics/unittwo/spectra/index.asp>
- Santa Barbara City College: This simulation shows the absorption and emission of photons and builds up the emission line spectrum of hydrogen.
<http://science.sbcc.edu/physics/flash/siliconsolarcell/>

7.5 Assessment

End of topic 7 test

Go online



The following test contains questions covering the work from this topic.



The following data should be used when required:

Planck's constant $h = 6.63 \times 10^{-34} \text{ J s}$

Q16: The power of light hitting an area of 2.1 m^2 is found to be 2.7 W .

Calculate the irradiance of light, in W m^{-2} , within the area.

.....

Q17: How many joules of light energy must be incident each second on an area of 3.5 m^2 if the irradiance is measured to be 1.01 W m^{-2} ?

.....

Q18: The irradiance of a point source of light is 0.5 W m^{-2} at a distance of 5.4 m. Calculate the irradiance of the source, in W m^{-2} , at a distance of 6.5m.

.....

Q19: Which one of the following statements about point sources is **false**?

- A) Radiation from a point source obeys the inverse square law.
- B) Doubling the distance from a point source halves the irradiance of radiation.
- C) A spotlight is not a point source.
- D) Point sources radiate equally in all directions.

.....

Q20: A spotlight produces a circle of light of power 8.7 W on a theatre stage.

If the irradiance of light, measured at the stage, is found to be 7.5 W m^{-2} , calculate the area, in m^2 , of the circle of light on the stage.

.....

Q21: An electron makes a downward energy jump of $2.4 \times 10^{-19} \text{ J}$.

What is the frequency, in $\times 10^{14} \text{ Hz}$, of the emitted photon?

.....

Q22: An electron orbiting an atom of a gas absorbs a photon of frequency $4.9 \times 10^{14} \text{ Hz}$.

How much energy, in J, does the electron gain?

.....

Q23: The ground state of an atom has an energy level of $-2.3 \times 10^{-18} \text{ J}$.

What is the minimum amount of energy, in J, a photon must have in order to ionise an electron in the ground state of the atom?

.....

Q24: An electron on energy level $W_2 = -1.74 \times 10^{-19} \text{ J}$ emits a photon by jumping to a lower energy level $W_1 = -5.35 \times 10^{-19} \text{ J}$.

What is the frequency, in Hz, of the emitted photon?

.....

Q25: An electron on energy level $W_1 = -1.95 \times 10^{-19} \text{ J}$ absorbs a photon of frequency $2.59 \times 10^{14} \text{ Hz}$ and jumps to a lower energy level W_2

What is the energy level, in J, of W_2 ?

Topic 8

End of unit test

Contents

8.1 Open ended and skill based questions	154
8.2 Course style questions	156
8.3 End of unit assessment	162

8.1 Open ended and skill based questions



Open ended questions and skill based questions

Q1: A fusion reactor has been described as a "*star in a jar*".

Use your knowledge of physics to comment on this description.

(3 marks)

.....

Q2: The threshold frequency of caesium is 4.7×10^{14} Hz.

A photon of radiation with a frequency just greater than the frequency of a violet photon is incident on a piece of caesium. This higher frequency photon causes the emission of a photoelectron from the surface of the caesium.

Estimate the kinetic energy of this photoelectron. You must justify your estimate by calculation.

(4 marks)

.....

Q3: A student uses two methods to accelerate electrons through a known potential difference and measure the velocity of the electron when it hits a target. The expected velocity on hitting the target is 2.45×10^6 m s⁻¹. Each method is repeated a number of times and the following table of results is obtained.

Method	Velocity of electron on hitting target (* 10^6 m s ⁻¹)					
	1	2	3	4	5	6
1	2.39	2.26	2.31	2.38	2.59	2.48
2	2.21	2.51	2.37	2.34	2.53	2.64

Assume that the scale reading uncertainty in these values is negligible.

Evaluate these two methods in terms of the accuracy and precision of the results obtained.

(4 marks)

.....

Q4: A student is investigating how the irradiance varies with the distance from a lamp. The investigation was carried out in a dark room and the lamp can be thought of as a point source. The results were used to produce the following graph.

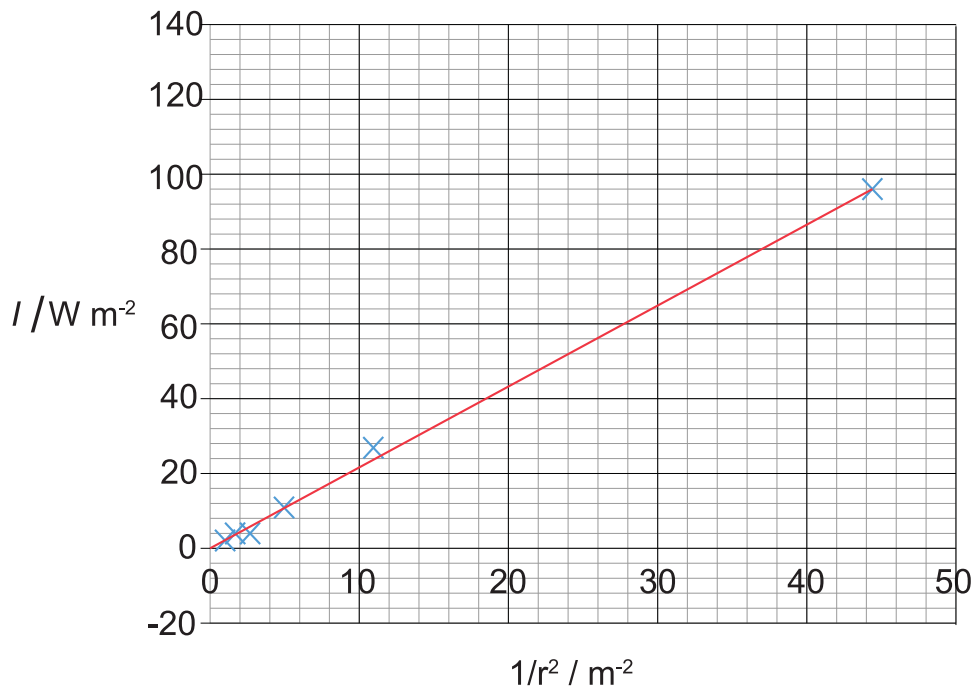

The irradiance I due to a lamp is given by the relationship

$$I = \frac{P}{4 \times \pi \times r^2}$$

Where

- I is the irradiance due to the lamp in W m^{-2} ;
- P is the power of the lamp in watts;
- r is the distance from the lamps in metres.

Use this relationship and the gradient of the graph to calculate the power of the lamp.

(3 marks)

.....

Q5: A student reads the following statement:

"Using a particle collider to understand the structure of matter is like trying to figure out how a watch works by slamming two of them together and looking at the pieces."

Using your knowledge of physics, discuss the relevance of this statement.

(3 marks)

8.2 Course style questions



Course style questions

Q6:

1. The following table shows a range of distances in order of increasing length.

diameter of proton	X	diameter of atom	wavelength of visible light	height of human	diameter of Earth	Y	diameter of solar system
--------------------	---	------------------	-----------------------------	-----------------	-------------------	---	--------------------------

- a) Give an example of a distance that would be at position X in the table. (1 mark)
- b) Give an example of a distance that would be at position Y in the table. (1 mark)
2. An electron is an example of a subatomic particle.
Describe one piece of experimental evidence which supports the existence of electrons. (2 marks)
3. A neutron 1_0n decays to a particle a_bX by the emission of a beta particle ${}^0_{-1}\beta$ and an antineutrino ${}^0_0\bar{\nu}$.
This neutron beta decay is represented by the statement below.
- $${}^1_0n \rightarrow {}^a_bX + {}^0_{-1}\beta + {}^0_0\bar{\nu}$$
- a) State the values of a and b for the particle a_bX . (1 mark)
- b) Name the particle a_bX . (1 mark)
4. An electron is known to have an antimatter particle.
- a) Name this antimatter particle. (1 mark)
- b) Compare the properties of an electron and its antimatter particle. (1 mark)
- c) State why electron anti-matter particles are rarely detected in the universe. (1 mark)

.....

Q7: A linear accelerator can be used to accelerate protons. These high energy protons can then be used in the treatment of cancer.

The linear accelerator consists of a series of five drift tubes.

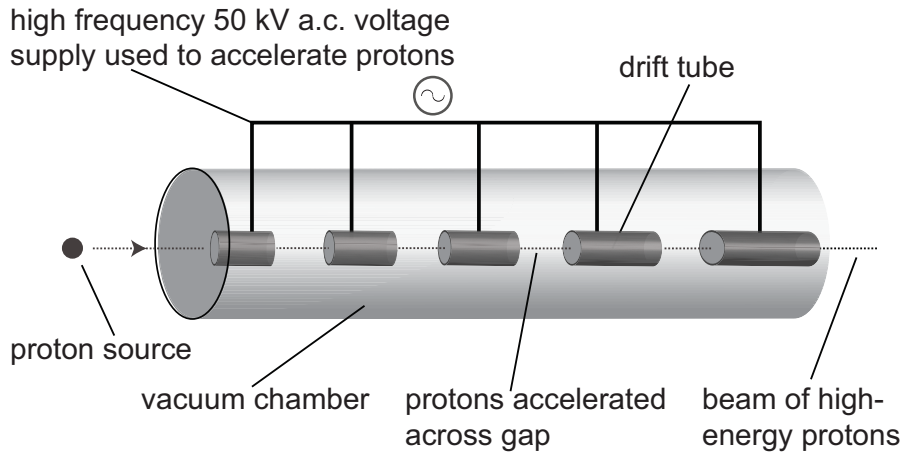

The protons are accelerated across the gap between successive drift tubes by a high frequency a.c. voltage of 50 kV.

- State what is meant by a *voltage of 50 kV*.
(1 mark)
- Show that the work done on a proton, as it accelerates across the gap between successive drift tubes is $8.0 \times 10^{-15} \text{ J}$.
(2 marks)
- The kinetic energy of a proton as it passes through the first drift tube is $3.0 \times 10^{-15} \text{ J}$. Calculate the velocity of a proton as it leaves the fifth drift tube.
(5 marks)
- Explain why the length of the first drift tube is short compared to the length of the final drift tube.
(2 marks)
- Magnets are placed around the accelerator. Explain why this enables a narrow beam of protons to be produced.
(1 mark)

.....

Q8: The following statement describes a nuclear reaction that takes place in a star:

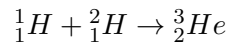

1. State the name of this type of reaction.

(1 mark)

2. The symbol for the Helium nucleus is ${}^3_2\text{He}$.

What information about the nucleus is provided by the following numbers?

a) 2

(1 mark)

b) 3

(1 mark)

3. The mass of the particles involved are as follows:

$$\text{mass of } {}^1_1\text{H} = 1.673 \times 10^{-27} \text{ kg}$$

$$\text{mass of } {}^2_1\text{H} = 3.344 \times 10^{-27} \text{ kg}$$

$$\text{mass of } {}^3_2\text{He} = 5.007 \times 10^{-27} \text{ kg}$$

Calculate the energy released by one of these reactions.

(3 marks)

4. A student reads the following in a scientific magazine:

The proportion of hydrogen in a new star is higher than the proportion of hydrogen in an old star.

Explain why the proportion of hydrogen in a star decreases as it gets older.

(2 marks)

.....

Q9:

1. A student is investigating the relationship between the angle an incident ray makes on a glass block and the angle at which it is refracted within the glass block.

A green laser is directed onto the glass block as shown.

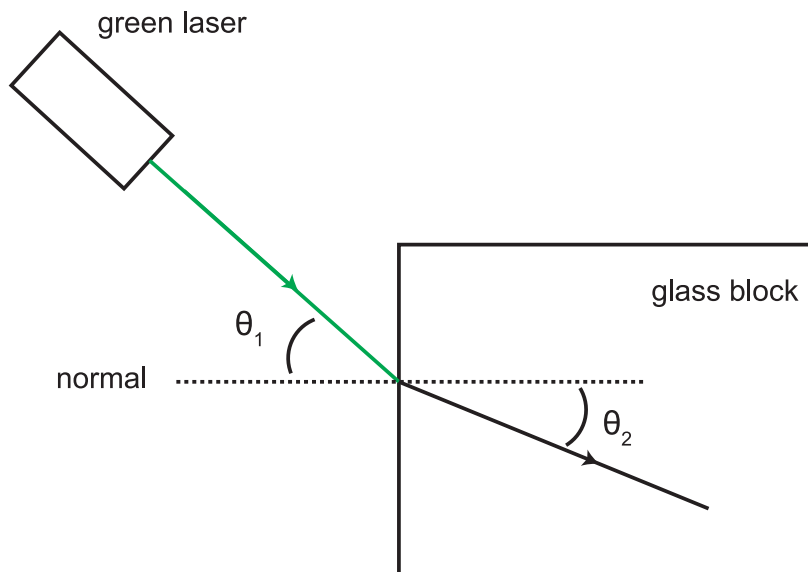

The student measures the angle of incidence in the air θ_1 and the angle of refraction in the glass θ_2 as shown. The student then calculates the sine value for each angle. The graph below displays the student's calculated values.

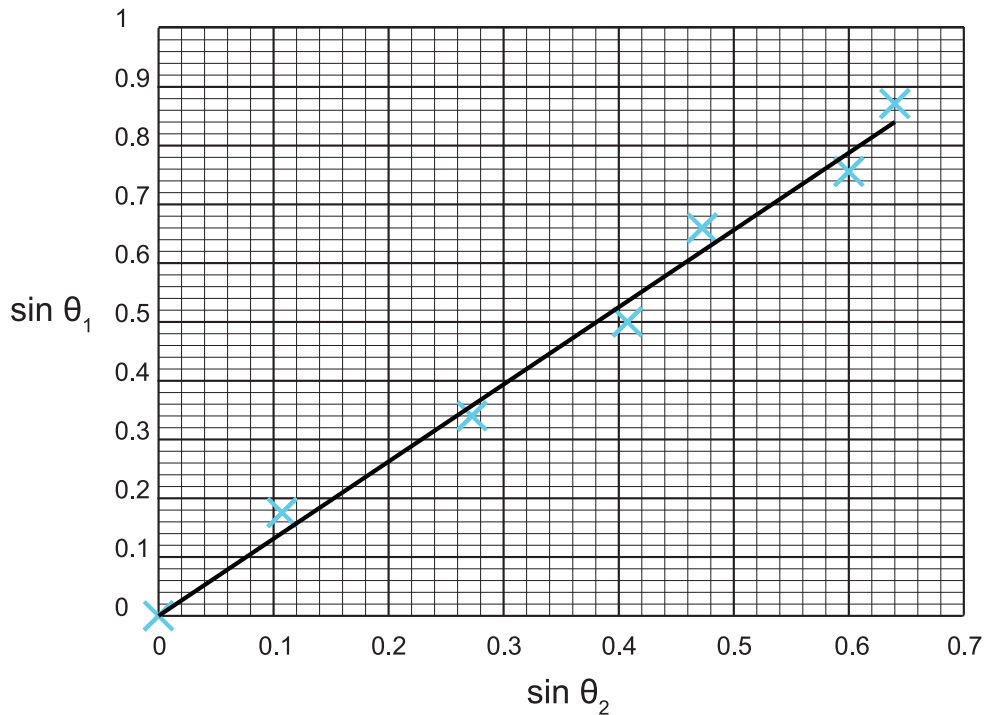

a) Explain why the angle of incidence in the air θ_1 and the angle of refraction in the glass θ_2 are not the same value. (1 mark)

b) Use information from the graph to calculate the refractive index of the glass for this green light. (3 marks)

2. In another investigation light from a red waterproof laser is directed towards the surface of a liquid as shown:

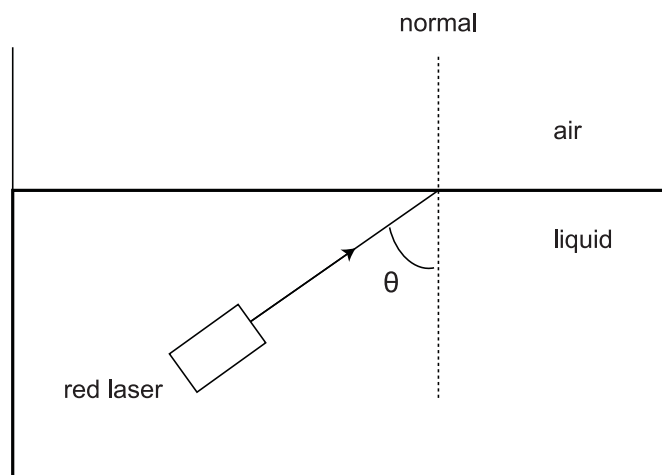

a) Light from the red laser has a wavelength of 452 nm in the liquid and 633 nm in air. Show that the refractive index of the liquid for this light is 1.4.

(2 marks)

- b) The position of the laser is adjusted so that the angle θ is 58° . Describe what will happen to the ray of red light at the surface of the liquid.
You must justify your answer by calculation.

(4 marks)

- c) The red waterproof laser is replaced by a white light source which is also waterproof. The white light source is adjusted so that the angle θ is once again 58° . Describe what will happen to the ray of white light at the surface of the liquid.
You must justify your answer.

(3 marks)

.....

Q10: A student is investigating interference of sound waves. A signal generator is connected to two loudspeakers, LS1 and LS2, shown as follows. (Diagram not to scale.)

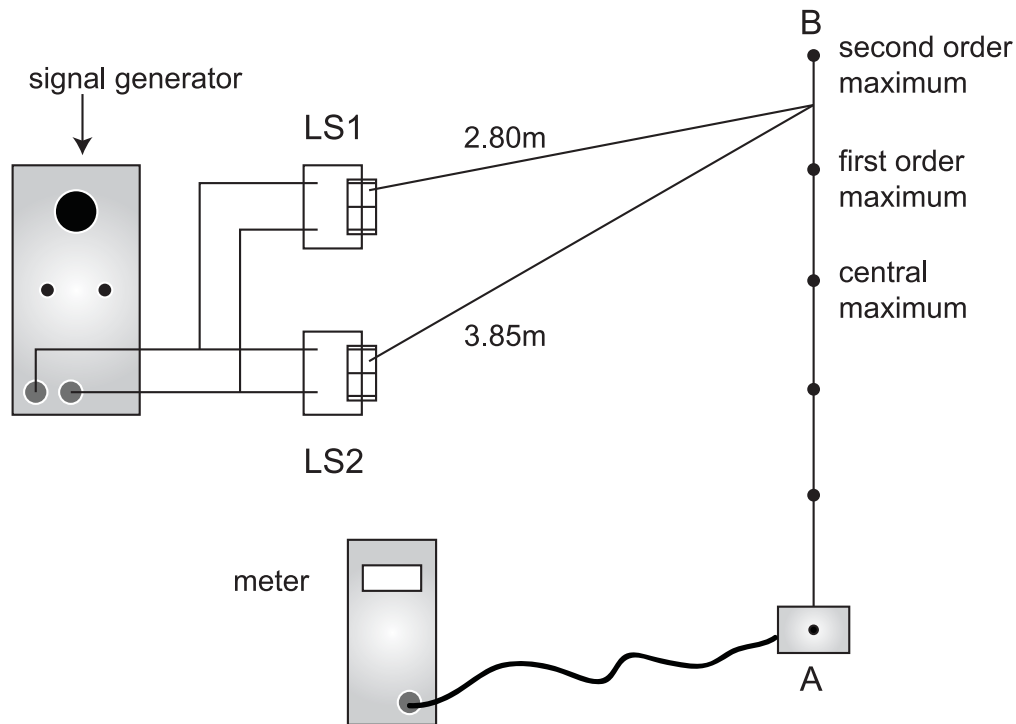

1. As the detector is moved from A to B, the reading on the meter increases and decreases several times.
Explain, in terms of the phase of the waves, how the pattern of maxima and minima is produced.

(1 mark)

2. The measurements of the distance from each loudspeaker to a minimum are shown.
Calculate the wavelength of the sound waves.

(3 marks)

3. The student places the detector at this minimum and does not move it from this position. The frequency of the sound is gradually increased by altering the signal generator. The student notices that the meter reading repeatedly increases and decreases as the frequency is increased..

Explain the student's observation.

(3 marks)

4. The student reports that "*to ensure high precision, low frequency sound should be used in this investigation*".

Explain if you agree or disagree with the student's statement.

You must justify your answer.

(2 marks)

8.3 End of unit assessment

End of unit 2 test

Go online



The following data should be used when required:

Mass of an electron m_e	$9.11 \times 10^{-31} \text{ kg}$
Magnitude of the charge on an electron e	$1.60 \times 10^{-19} \text{ C}$
Planck's constant h	$6.63 \times 10^{-34} \text{ J s}$
Speed of light c	$3.0 \times 10^8 \text{ m s}^{-1}$
1 atomic mass unit u	$1.66 \times 10^{-27} \text{ kg}$

Q11: The following is list of statements about particles. Choose all those which are correct.

1. Baryon number and strangeness are conserved quantities in reactions involving particles.
2. The Z^0 particle is a mediator for the weak force.
3. The electron is made up of quarks.
4. Newton's law of gravitation does not apply to fundamental particles.
5. A quark is about 10^{-12} m in size.
6. The graviton acts as a mediator for the electromagnetic force.
7. The neutrino is a fundamental particle.
8. A quark is a lepton.
9. Particles in the hadron group are made up of three quarks.
10. The electron is a fundamental particle.
11. A proton is made up of three quarks.
12. A meson particle is made up of two quarks.
13. Neutrinos are produced during beta decay.
14. Hadrons comprise mesons, baryons and leptons.
15. The neutron is a fundamental particle.
16. The strong force is felt by quarks but not by leptons.
17. The baryon number of an electron is zero.
18. Quarks have properties known as mass, flavour, charge, colour and brightness.
19. An alpha particle comprises 6 quarks.
20. The strong force is mediated by gluons.
21. A quark is a fundamental particle.

.....

Q12: An electron is accelerated from rest by a potential difference of 600 V. What is the final velocity of the electron?

.....

Q13: The apparatus below is for accelerating alpha particles.

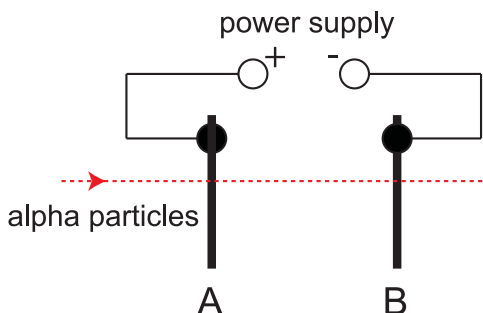

An alpha particle travelling at a speed of $2.60 \times 10^6 \text{ ms}^{-1}$ passes through a hole in plate A. The mass of an alpha particle is $6.64 \times 10^{-27} \text{ kg}$ and its charge is $3.2 \times 10^{-19} \text{ C}$.

- When the alpha particle reaches plate B, its kinetic energy has increased to $3.05 \times 10^{-14} \text{ J}$. Calculate the work done on the alpha particle as it moves from plate A to plate B.
- Calculate the potential difference between plates A and B.
- The apparatus is now adapted to accelerate **electrons** from A to B through the same potential difference. How does the increase in the kinetic energy of an electron compare with the increase in kinetic energy of the alpha particle in part 1? Justify your answer.

.....

Q14: A parent nuclide P with a mass number 230 and atomic number 110 undergoes fission and splits into two daughter nuclides, X and Y. The mass number of X is 105.

- What is the mass number of nuclide Y?
- The atomic number of Y is 50. What is the atomic number of nuclide X?

.....

Q15: The following equation shows a nuclear reaction.



The masses of the particles involved in the reaction are given below:

$$\text{mass of } {}_{92}^{235}\text{U} = 390.2 \times 10^{-27} \text{ kg}$$

$$\text{mass of } {}_{54}^{136}\text{Xe} = 225.6 \times 10^{-27} \text{ kg}$$

$$\text{mass of } {}_{42}^{98}\text{Mo} = 162 \times 10^{-27} \text{ kg}$$

$$\text{mass of } {}_0^1\text{n} = 1.675 \times 10^{-27} \text{ kg}$$

The mass of the β -particles can be ignored.

- Calculate the loss in mass, per uranium nucleus, when this reaction takes place.
- Calculate the energy released, for each uranium nucleus, when this reaction takes place.

.....

Q16: Which option correctly completes the statement:

Compared with a proton, an alpha particle has:

- a) twice the mass and twice the charge.
 - b) twice the mass and the same charge.
 - c) four times the mass and twice the charge.
 - d) four times the mass and the same charge.
 - e) twice the mass and four times the charge.
-

Q17: The minimum frequency needed to cause photoelectric emission from a material is 9.1×10^{14} Hz.

1. Calculate the work function of the material.
 2. A sample of this material is irradiated with ultraviolet radiation of frequency 2.1×10^{15} Hz. Calculate the maximum kinetic energy of the emitted photoelectrons.
-

Q18: A student is carrying out an experiment to investigate the interference of sound waves. She sets up the following apparatus.

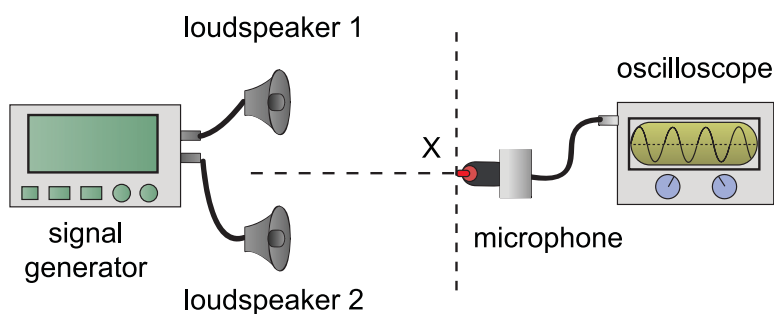

The microphone is initially placed at point X which is the same distance from each loudspeaker. A maximum is detected at X.

- a) The microphone is now moved to the first minimum at Y as shown.

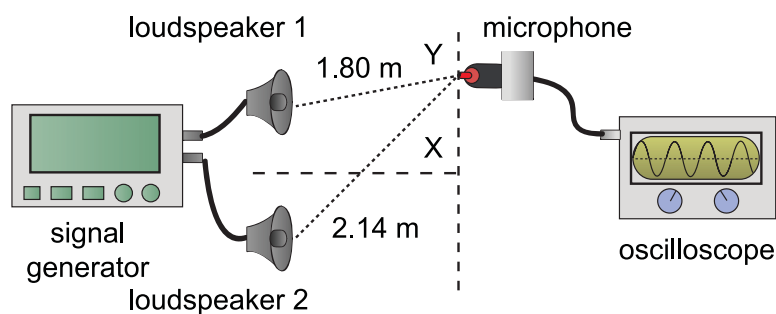

Calculate the wavelength of the sound waves.

- b) Loudspeaker 1 is now disconnected. What happens to the amplitude of the sound detected by the microphone at Y? Explain your answer.

.....
Q19: Monochromatic laser light is directed at a diffraction grating that has 25 lines per millimetre. An interference pattern is produced on a screen. The angle between the central maximum and the *second* maximum to one side is 1.25° .

1. What is the separation of the lines on the diffraction grating?
2. What is the wavelength of the light used? Give your answer to the nearest nm.

.....
Q20: A laser produces a narrow beam of monochromatic light.

1. Red light from a laser passes through a grating as shown.

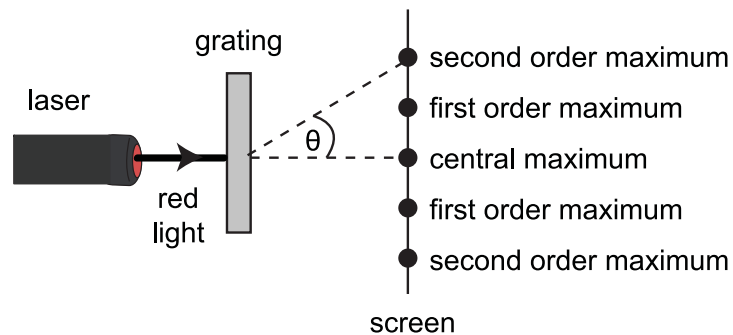

A series of maxima and minima is observed.

Explain in terms of waves how a **minimum** is produced.

2. The laser is now replaced by a second laser, which emits blue light. Explain why the observed maxima are now closer together.
3. The wavelength of the blue light from the second laser is 4.74×10^{-7} m.
 The spacing between the lines on the grating is 2.00×10^{-6} m.
 Calculate the angle between the central maximum and the second order maximum.

Q21: A ray of monochromatic light refracts into and out of a rectangular perspex block as shown in the following diagram.

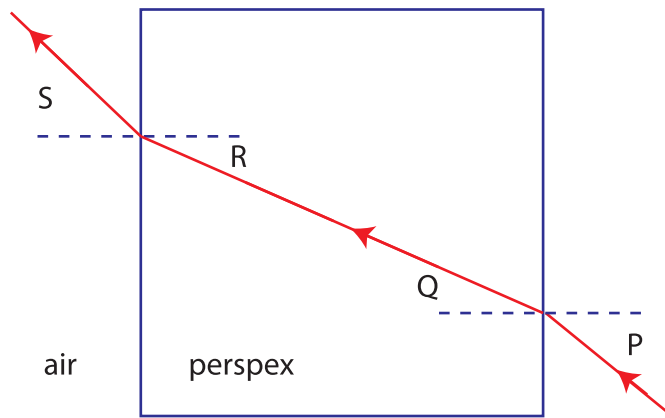

Angle P is 32° . The refractive index of the perspex for the light used is 1.50.

1. Calculate angle Q. Give your answer to the nearest degree.
2. Calculate angle S. Give your answer to the nearest degree.
3. What is the critical angle for the light in the perspex? Give your answer to the nearest degree.
4. What is the speed of the light in the perspex?

.....

Q22: At a distance of 1.9 m from a point source of light, the irradiance of light is 5.2 W m^{-2} . What is the irradiance of the light at a distance of 3.2 m from the same point source?

.....

Q23: The diagram shows a light sensor connected to a voltmeter. A small lamp is placed in front of the sensor.

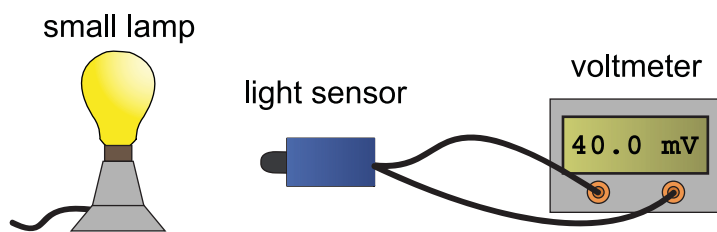

The reading on the voltmeter is 20 mV for each 1.0 mW of power incident on the sensor.

1. The reading on the voltmeter is 40.0 mV. The area of the light sensor is $8.0 \times 10^{-5} \text{ m}^2$. Calculate the irradiance of light on the sensor.
2. The small lamp is replaced by a different source of light. Using this new source, a student investigates how irradiance varies with distance. The results are shown.

Distance / m	0.5	0.7	0.9
Irradiance / Wm^{-2}	1.1	0.8	0.6

Can this new source be considered to be a point source of light?

Use **all** the data to justify your answer.

.....

Q24: Electrons which orbit the nucleus of an atom can be considered as occupying discrete energy levels. The following diagram shows some of the energy levels for a particular atom.

E_3 ————	$-5.1 \times 10^{-19} \text{ J}$
E_2 ————	$-9.0 \times 10^{-19} \text{ J}$
E_1 ————	$-18.6 \times 10^{-19} \text{ J}$
E_0 ————	$-24.4 \times 10^{-19} \text{ J}$

1. Radiation is produced when electrons make transitions from a higher to a lower energy level. Which transition, between these energy levels, produces radiation with the shortest wavelength? Justify your answer.
2. An electron is excited from energy level E_2 to E_3 by absorbing light energy. What frequency of light is used to excite this electron?
3. Another source of light has a frequency of $4.6 \times 10^{14} \text{ Hz}$ in air. A ray of this light is directed into a block of transparent material as shown.

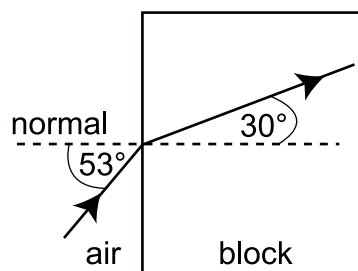

Calculate the wavelength of the light in the block.

Appendix A

Units, prefixes and scientific notation

Contents

A.1 Symbols and units used in Unit 2: Particles and waves	170
A.2 Significant figures	171
A.3 Scientific notation	173
A.3.1 Prefixes	174

A.1 Symbols and units used in Unit 2: Particles and waves

Physics Quantity	Symbol	Unit	Unit Abbreviation
electric charge	Q	coulomb	C
voltage, potential difference	V	volt	V
Planck's constant	h	joule second	J S
frequency	f	hertz	Hz
threshold frequency	f_0	hertz	Hz
energy level	or E_1 E_2	joule	J
wavelength	λ	metre	m
period	T	second	s
angle	θ	degree	°
order of interference, number of complete wavelengths in a path difference	m	—	—
refractive index	n	—	—
critical angle	θ_c	degree	°
irradiance	I	watt per metre square	W m^{-2}
area	A	metre square	m^2

A.2 Significant figures

It is important when calculating numerical values that the final answer is quoted to an appropriate number of significant figures.

As a general rule, the final numerical answer that you quote should be to the same number of significant figures as the data given in the question.

The above rule is the key point but you might like to note the following points:

1. The answer to a calculation cannot increase the number of significant figures that you can quote.
2. If the data is not all given to the same number of significant figures, identify the least number of significant figures quoted in the data. This least number is the number of significant figures that your answer should be quoted to.
3. When carrying out sequential calculations carry many significant figures as you work through the calculations. At the end of the calculation, round the answer to an appropriate number of significant figures.
4. In the Higher Physics course quoting an answer to three significant figures will usually be acceptable.

Examples

1. The current in a circuit is 6.7 A and the voltage across the circuit is 21 V. Calculate the resistance of the circuit.

Note: Both of these pieces of data are given to two sig. figs. so your answer must also be given to two sig figs.

$$I = 6.7 \text{ A}$$

$$V = 21 \text{ V}$$

$$R = ?$$

$$V = I R$$

$$21 = 6.7 \times R$$

$$R = 3.1343$$

$$R = 3.1 \Omega$$

round to 2 sig figs

.....

2. A 5.7 kg mass accelerates at 4.36 m s⁻². Calculate the unbalanced force acting on the mass.

Note: The mass is quoted to two sig. figs and the acceleration is quoted to three sig. figs. so the answer should be quoted to two sig figs.

$$m = 5.7 \text{ kg}$$

$$a = 4.36 \text{ m s}^{-2}$$

$$F = ?$$

$$F = m a$$

$$F = 5.7 \times 4.36$$

$$F = 24.852$$

$$F = 25 \text{ N}$$

round to 2 sig figs

.....

3. A car accelerates from 0.5037 m s^{-1} to 1.274 m s^{-1} in a time of 4.25 s .

The mass of the car is 0.2607 kg .

Calculate the unbalanced force acting on the car.

Note: The time has the least number of sig figs, three, so the answer should be quoted to three sig figs.

$$u = 0.5037 \text{ m s}^{-1}$$

$$v = 1.274 \text{ m s}^{-1}$$

$$t = 4.25 \text{ s}$$

$$m = 0.2607 \text{ kg}$$

Step 1: calculate a

$$a = \frac{v - u}{t}$$

$$a = \frac{1.274 - 0.5037}{4.25}$$

$$a = 0.181247 \text{ m s}^{-2}$$

Step 2: calculate F

$$F = m a$$

$$F = 0.2607 \times 0.18147$$

$$F = 0.0472511$$

$$F = 0.0473 \text{ N}$$

round to 3 sig figs

Quiz questions

Go online



Q1: A car travels a distance of 12 m in a time of 9.0 s.
The average speed of the car is:

- a) 1.3333
- b) 1.33
- c) 1.3
- d) 1.4
- e) 1

.....

Q2: A mass of 2.26 kg is lifted a height of 1.75 m. The acceleration due to gravity is 9.8 m s^{-2} .

The potential energy gained by the mass is:

- a) 38.759 J
- b) 38.76 J
- c) 38.8 J
- d) 39 J
- e) 40 J

.....

Q3: A trolley of 5.034 kg is moving at a velocity of 4.03 m s^{-1} .
The kinetic energy of the trolley is:

- a) 40.878 J
- b) 40.88 J
- c) 40.9 J
- d) 41 J
- e) 40 J

A.3 Scientific notation

When carrying out calculations, you should be able to use scientific notation. This type of notation has been used throughout the topics where necessary, so you will already be familiar with it

Remember scientific notation is used when writing very large or very small numbers. When a number is written in scientific notation there is usually one, nonzero number, before the decimal point.

Examples

1. The speed of light is often written as $3 \times 10^8 \text{ m s}^{-1}$.

This can be converted into a number in ordinary form by moving the decimal point 8 places to the right, giving $300\,000\,000 \text{ m s}^{-1}$.

.....

2. The capacitance of a capacitor may be 0.000 022 F.

This very small number would often be written as 2.2×10^{-5} F. The $\times 10^{-5}$ means move the decimal point 5 places to the left.

Make sure you know how to enter numbers written in scientific notation into your calculator.

A.3.1 Prefixes

There are some prefixes that you must know. These are listed in the following table:

Prefix	Symbol	Symbol
pico	p	$\times 10^{-12}$
nano	n	$\times 10^{-9}$
micro	μ	$\times 10^{-6}$
milli	m	$\times 10^{-3}$
kilo	k	$\times 10^3$
mega	M	$\times 10^6$
giga	G	$\times 10^9$

In Higher Physics you are expected to know and remember the meaning of all of these prefixes.

Glossary

Absolute refractive index

the absolute refractive index (or more simply, the refractive index), n , of a medium is the ratio $\frac{\sin \theta_1}{\sin \theta_2}$, where θ_1 is in a vacuum, and θ_2 is in the medium

Achromatic doublet

a lens made from two different types of glass, to compensate for the fact that refractive index depends on the frequency of the incident light

Angle of incidence

the angle between the incident ray and the normal

Angle of refraction

the angle between the refracted ray and the normal

Atomic mass units (u)

by definition one twelfth of the mass of a carbon-12 nucleus

Atomic number

the number of protons in an atomic nucleus. It is this number that determines the element

Binding energy

the energy needed to split a nucleus into its separate nucleons

Chain reaction

when a nucleus undergoes fission it releases neutrons that can go on to collide with other nuclei, causing further fission reactions. If there is a sufficient concentration of suitable nuclei, the process becomes self-sustaining.

Coherent waves

coherent waves are waves that have the same frequency, speed and have a constant phase relationship

Collimator

part of a spectrometer that is used to produce a parallel beam of light

Critical angle

the maximum value of the angle between the normal and the ray in glass, θ_{glass} , for which refraction can occur

Diffraction

an effect that causes waves to bend as they go past the end of an obstacle or through a small gap in a barrier

Dispersion

the process of splitting up light into its constituent colours

Electromagnetic waves

the spectrum of waves that includes radio, visible light, X-rays etc

Energy yield

the amount of energy released per unit mass of fuel, for example coal can provide about 30 MJ/kg, whereas uranium has an energy yield of about 500 000 MJ/kg

Excited state

any atomic energy level higher than the ground state

Ferromagnetic

materials in which the magnetic fields of the atoms line up parallel to each other in regions known as magnetic domains

Fission

the splitting of a large atomic nucleus into smaller fragments, with the resultant release of excess energy

Gold leaf electroscope

device used to measure small amounts of charge

Grating

a transparent slide of glass or plastic that has a very large number of equally-spaced grooves machined on to its surface. Each groove acts as a source for coherent beams of light.

Ground state

the lowest energy level of an atom

Hologram

a hologram is a virtual image of an object that will appear to be three-dimensional to an observer

Induced fission

the deliberate splitting of a large nucleus caused by the collision of the nucleus with a neutron

Ionisation level

the energy level at which an electron can break free from an atom

Irradiance

the power per unit area of radiation incident on a surface

Isotopes

different forms of the same element. The isotopes of an element contain the same number of protons but have different numbers of neutrons.

Line absorption spectrum

a spectrum that consists of narrow dark lines across an otherwise continuous spectrum

Line emission spectrum

a spectrum consisting of narrow lines of light, the position of which depend on the substances producing the light

Magnetic domains

regions in a ferromagnetic material where the atoms are aligned with their magnetic fields parallel to each other

Magnetic field

a magnetic field is a region in which a moving charge experiences a magnetic force

Magnetic poles

one way of describing the magnetic effect, especially with permanent magnets. There are two types of magnetic poles - north and south. Opposite poles attract, like poles repel

Mass defect

the difference between the mass of a nucleus and the total mass of an equal number of individual nucleons

Mass number

the total number of nucleons in the nucleus of an atom

Monochromatic

radiation consisting of a single frequency

Monochromatic light

light of one wavelength (and therefore one colour)

Normal

a line drawn at right angles to a surface or the boundary between two different media

Nucleon

the general term for protons and neutrons

Nuclide

the nuclei of one particular isotope. These nuclei all have the same atomic number and mass number.

Path difference

the difference in path lengths of two sets of waves

Photocathode

the terminal from which electrons will be emitted due to the photoelectric effect

Photoelectric effect

the emission of electrons from a metal due to the effect of electromagnetic radiation

Photoelectrons

free electrons produced by the photoelectric effect

Photoemission

the emission of electrons from a material caused by light shining on it

Photon

the particle of electromagnetic radiation

Potential difference

the potential difference between two points is a measure of the work done in moving one coulomb of charge between the two points

Principle of reversibility

the principle of reversibility states that a ray of light will follow the same path in the opposite direction when it is reversed

Radioactive decay series

a chain of radioactive decays as a radioactive element changes to eventually become a stable, non-radioactive element

Radioisotope

short for radioactive isotope

Radionuclide

short for radioactive nuclide

Refraction

refraction occurs when a wave goes from one medium into another. When a wave is refracted, its speed and wavelength always change; its frequency never changes; its direction sometimes changes.

Spectrometer

an instrument that can make precise measurements of the spectra produced by different light sources

Spontaneous fission

the random splitting of a large atomic nucleus due to the internal processes within the nucleus

Stopping potential

the minimum voltage required to reduce photoelectric current to zero

Telescope

the part of a spectrometer through which the spectrum is viewed

Threshold frequency

the minimum frequency of electromagnetic radiation that will cause photoemission for a particular substance

Total internal reflection

when a ray of light travelling in a more dense substance meets a boundary with a less dense substance at an angle greater than the critical angle, the ray is not refracted but is all reflected inside the more dense substance

Turntable

the stage or platform of a spectrometer on which the grating or prism sits. The turntable has an angular scale on it to allow measurements to be made.

Work function

the minimum energy required to cause photoemission from a particular substance

Hints for activities

Topic 2: Forces on charged particles

Charges, forces and fields: Questions

Hint 1:

The magnitude of the charge on a proton is equal to the fundamental charge.

Hint 2:

Read the following paragraph and try again.

An object can be charged by adding negatively-charged particles such as electrons, in which case it becomes negatively charged. An object may also be charged by removing electrons, making it positively charged. A negatively-charged object attracts a positively-charged object and objects that have similar charges repel each other.

Hint 3:

The definition of an **electric field** is: a region in space where a charge experiences a force.

Hint 4:

On screen simulation.

Topic 3: Nuclear reactions

Radioactive decay: Questions

Hint 1:

See the section titled Decay processes.

Hint 2:

Only alpha and beta decay result in the formation of a new element.

Hint 3:

Beta decay is the result of a neutron splitting into a proton and an electron. A different isotope means the mass number has changed but the element, atomic number, has not changed.

Hint 4:

Notice that the mass number is reduced by 4.

Hint 5:

For beta decay the atomic number increases by 1 and the mass number stays the same; for alpha decay the atomic number decreases by 2 and the mass number decreases by 4.

Mass-energy equivalence: Questions

Hint 1:

The total number of nucleons does not change.

Hint 2:

Calculate the total mass 'lost' - then use $E = mc^2$.

Hint 3:

Calculate the total mass 'lost' - then use $E = mc^2$.

Topic 4: Wave particle duality**Photoelectric effect: Questions****Hint 1:**

This is a straight application of the following equation.

$$E = hf$$

Hint 2:

First calculate the frequency then use the wave equation to calculate wavelength.

Hint 3:

You need to find the minimum frequency that will give a photon energy greater than the work function.

Hint 4:

The maximum kinetic energy equals the difference between the photon energy and the work function.

Topic 5: Diffraction and interference**Diffraction and interference: Questions****Hint 1:**

See the section titled Diffraction

Hint 2:

Look again at section titled Young's slits experiment.

Hint 3:

On screen animation demonstrating Young's slits.

Hint 4:

For constructive interference the path difference must be a whole number of wavelengths.

Hint 5:

For destructive interference the path difference must be an odd number of half-wavelengths.

The grating and white light spectra: Questions**Hint 1:**

First work out the separation d between adjacent grooves in the grating. Then use the following equation.

$$d \sin \theta = m\lambda$$

Hint 2:

Use the following equation to work out the angle of the first order maximum (i.e. when $m = 1$) then use it again to work out the angle of the second order maximum (i.e. when $m = 2$).

$$d \sin \theta = m\lambda$$

Hint 3:

See the section titled The spectrometer.

Hint 4:

The wavelengths of visible light can be found in section titled Definitions.

Hint 5:**Spectra produced by a prism and by a grating**

	Prism	Grating
Order of colours (deviated least to deviated most)	red, orange, yellow, green, blue, indigo, violet	violet, indigo, blue, green, yellow, orange, red
Central white maximum	no	yes
Number of spectra seen	one only	many, in pairs on both sides of the central white maximum
Spectrum produced by	refraction	interference

Topic 6: Refraction of light**Refractive index: Questions****Hint 1:**

Re-read section titled Refractive index.

Hint 2:

Remember angles are always measured between rays and the normal.

Hint 3:

This is a straight application of the following equation.

$$\frac{\sin \theta_1}{\sin \theta_2} = \text{constant}$$

Hint 4:

The frequency of a wave is determined by the source.

Hint 5:

You need to use the following equation.

$$\frac{\sin \theta_1}{\sin \theta_2} = \frac{\lambda_1}{\lambda_2} = \frac{v_1}{v_2}$$

Total internal reflection and critical angle: Questions**Hint 1:**

See the activity Critical angle and absolute refractive index in section titled Total internal reflection and critical angle for the derivation of this relationship.

Hint 2:

This is a straight application of the following equation.

$$n_{\text{medium}} = \frac{1}{\sin \theta_C}$$

$$\therefore \sin \theta_C = \frac{1}{n_{\text{medium}}}$$

Hint 3:

This is a straight application of the following equation.

$$n_{\text{medium}} = \frac{1}{\sin \theta_C}$$

$$\therefore \sin \theta_C = \frac{1}{n_{\text{medium}}}$$

Hint 4:

Applications of total internal reflection are described in the section titled Total internal reflection and critical angle.

Hint 5:

Each half of binoculars uses two prisms - see the following diagram for the effect of one prism.

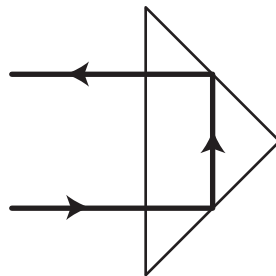

Prism used in binoculars (Porro prism)

Topic 7: Spectra**Irradiance calculations: Questions****Hint 1:**

- Remember to change the area units from cm^2 to m^2 .
- $\text{cm} \rightarrow \text{m}$, divide by 100.
- $\text{cm}^2 \rightarrow \text{m}^2$, divide by 100^2 , divide by 10,000.
- Note that the power is in mW, not W.

Hint 2:

Remember to change the time to seconds.

Hint 3:

The units kilojoules and minutes have to be changed to the correct SI units before you do the calculation.

Hint 4:

First work out the area of the circle - and be careful the diameter is given not radius.

Hint 5:

From equation $\text{power} = \text{irradiance} \times \text{area}$

Inverse square law: Questions**Hint 1:**

- $I_1 = 32$
- $d_1 = 2$
- $I_1 d_1^2 = I_2 d_2^2$
 $d_2 = 8$
- $I_2 = ?$

Hint 2:

The second distance is four times closer.

Hint 3:

The irradiance has gone up - so is the second observer closer or further away?

Hint 4:

First calculate the irradiance at a distance of 5 m then use the inverse square law.

Hint 5:

The irradiance of a laser does not follow the inverse square law.

Energy level calculations: Questions**Hint 1:**

You have to count all possible transitions between energy levels.

Hint 2:

This is a straight application of equation:

$$E = hf$$

Hint 3:

Calculate the maximum and minimum energies for the visible part of the spectrum.

Hint 4:

You need to know how much energy is needed to release an electron from the ground state - then use $E = hf$ to find the frequency of a photon with this energy.

Hint 5:

First work out the energy of the photon.

Appendix A: Units, prefixes and scientific notation

Quiz questions

Hint 1: Data is quoted to 2 sig figs so answer must be quoted to 2 sig figs.

Hint 2: The acceleration due to gravity is quoted to only 2 sig figs so the answer must be given to 2 sig figs.

Hint 3: The mass of the trolley is given to 4 sig figs and the velocity is given to 3 sig figs.

Answers to questions and activities

Topic 1: The standard model

Answers from page 7.

Q1: Decay 1: Baryon number is not conserved, so decay is not possible. Notice that the charge has been conserved, but the baryon number must also be conserved.

Decay 2: Both baryon number and charge are conserved, so decay is possible.

The Standard Model: Questions (page 7)

Q2: b) (i) and (ii) only

Q3: e) (i), (ii) and (iii)

Q4: b) (i) and (ii) only

Q5: d) (ii) and (iii) only

Q6: e) (i), (ii) and (iii)

Q7: d) The strong force is a short-range force.

The quark model and beta decay: Questions (page 15)

Q8: c) up; down; strange; charm; top; bottom

Q9: a) (iii) only

Q10: d) 3

Q11: b) weak force

End of topic 1 test (page 19)

Q12: Fundamental particles are particles which are thought to have no underlying structure. The electron is an example of a fundamental particle. It belongs to a group of particles called the leptons. Particles such as neutrons are not fundamental particles. These particles are members of a group known as the hadrons. The hadrons are divided into two sub-groups called the baryons and the mesons.

All hadrons comprise combinations of a fundamental particle called the quark. The baryons are made up of three quarks. There are six main types of quark. One type is called the up quark, another type is the top quark.

Q13:

- a) B
- b) B
- c) B

Q14:

- a) A
- b) A

Topic 2: Forces on charged particles**Charges, forces and fields: Questions (page 26)**

Q1: d) 6.25×10^{18}

Q2: e) Both spheres are positively charged.

Q3: a) experiences a force.

Q4: c)

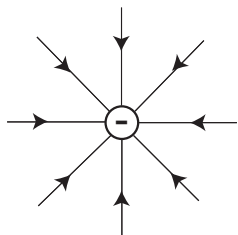
**Work done and potential difference: Questions (page 32)**

Q5: a) a measure of the work done in moving one coulomb of charge between the two points.

Q6: e) joule per coulomb

Q7: c) 40 J

Q8: b) 30 V

Q9: d) $4.2 \times 10^6 \text{ m s}^{-1}$

Magnetic fields and forces: Questions (page 36)

Q10: e) All magnets have two poles called north and south.

Q11: e) (i) and (iii) only

Q12: c) (iii) only

Q13: d) (i) and (ii) only

Q14: e) (i), (ii) and (iii)

Oersted's experiment (page 38)**Expected answer**

1. With no current in the wire, the compass needles point in the direction of the Earth's magnetic field.
2. A current through the wire produces a circular magnetic field centred on the wire.

3. The greater the current, the stronger is the magnetic field. This is shown by the separation of the field lines.
4. If the direction of the current is reversed, the direction of the magnetic field is also reversed.

Particle accelerators: Questions (page 46)

Q15: e) (ii) and (iii) only

Q16: b) (i) and (ii) only

Q17: d) oscillator

Q18: d) (i) and (ii) only

End of topic 2 test (page 49)

Q19: 1410

Q20: 2.7

Q21:

- a) 40
- b) electrons

Q22: 4×10^6

Q23: 4.0

Q24: 3.3

Q25:

- a) 4.7×10^3
- b) Protons, because the sphere gains energy in moving to the negative plate.

Q26: 15

Q27: A current through a wire produces a circular magnetic field. The direction electrons move in a magnetic can be worked out using the right hand rule.

Q28: Cathode ray tubes use electrical fields to accelerate electrons to high velocities. CRO tubes are very simple forms of linear accelerator. The longest linear accelerator is 3.2 km long. Circular accelerators such as the cyclotron and synchrotron can produce higher energy collisions than linear accelerators. In synchrotron accelerators beam of particles travelling in the opposite directions are allowed to collide.

Topic 3: Nuclear reactions**Radioactive decay: Questions (page 57)**

Q1: c) (i) and (ii) only

Q2: b) A new element is always formed after radioactive decay.

Q3: a) (i) only

Q4: a) alpha particle

Q5: b) ${}_{91}^{234}\text{Pa} \rightarrow {}_{92}^{234}\text{U} \rightarrow {}_{90}^{230}\text{Th}$

Mass-energy equivalence: Questions (page 65)

Q6: c) 3

Q7: d) $2.916 \times 10^{-11}\text{J}$

Q8: b) $2.070 \times 10^{-12}\text{J}$

End of topic 3 test (page 67)

Q9:

1. 92
2. 146
3. 238

Q10:

1. 233
2. 87

Q11:

1. 4
2. 16
3. 0

Q12:

1. Spontaneous fission
2. 2
3. 2.79×10^{-11}

Q13: 0.40×10^{-11}

Topic 4: Wave particle duality**Photoelectric investigation: Questions (page 72)**

Q1: b) No

Q2: b) No

Q3: b) No

Q4: a) Yes

Q5: a) Yes

Photoelectric effect: Questions (page 79)

Q6: b) 4.81×10^{-19} J

Q7: b) 6.63×10^{-7} m

Q8: d) 9.4×10^{14} Hz

Q9: a) 2.59×10^{-20} J

End of topic 4 test (page 82)

Q10: 42.8×10^{-20}

Q11: 3.3

Q12: 8.6×10^{-20}

Q13: 3.0×10^{-18}

Topic 5: Diffraction and interference**Diffraction and interference: Questions (page 92)**

Q1: a) waves go past the end of a barrier.

Q2: c) interference of waves.

Q3: b) 24 cm and 28 cm

Q4: d) 22 cm and 26 cm

The grating and white light spectra: Questions (page 103)

Q5: b) 528 nm

Q6: d) 11.7°

Q7: d) (i) and (ii) only

Q8: e) red - 700 nm, green - 560 nm, blue - 470 nm

Q9: e) (i), (ii) and (iii)

End of topic 5 test (page 106)

Q10: 325 nm

Q11:

- a) E
- b) 4
- c) 2
- d) 1.81
- e) 1.82
- f) 4
- g) D

Q12:

- a) C
- b) D
- c) 20.8

Topic 6: Refraction of light**Refractive index of a medium (page 111)****Expected answer****Answers from page 118.****Q1:**

$$n_{\text{glass}} = \frac{v_{\text{air}}}{v_{\text{glass}}}$$

1. $\therefore 1.68 = \frac{3.00 \times 10^8}{v_{\text{glass}}}$

$$\therefore v_{\text{glass}} = \frac{3.00 \times 10^8}{1.68}$$
$$\therefore v_{\text{glass}} = 1.79 \times 10^8 \text{ m s}^{-1}$$
$$n_{\text{glass}} = \frac{\lambda_{\text{air}}}{\lambda_{\text{glass}}}$$

2. $\therefore 1.68 = \frac{400 \times 10^{-9}}{\lambda_{\text{glass}}}$

$$\therefore \lambda_{\text{glass}} = \frac{400 \times 10^{-9}}{1.68}$$
$$\therefore \lambda_{\text{glass}} = 238 \text{ nm}$$

Refractive index: Questions (page 119)**Q2:** e) (ii) and (iii) only**Q3:** b) $\frac{\sin 30^\circ}{\sin 22^\circ}$ **Q4:** c) 1.63**Q5:** a) (i) only**Q6:** d) wavelength 400 nm; speed $2.00 \times 10^8 \text{ m s}^{-1}$

Total internal reflection and critical angle: Questions (page 127)

Q7: d) $\sin \theta_C = \frac{1}{n_{\text{medium}}}$

Q8: c) 41.8°

Q9: c) 1.31

Q10: b) an achromatic doublet lens

Q11: a) leave its direction unchanged but displace it sideways.

End of topic 6 test (page 130)

Q12: c) 20°

Q13:

- a) 70
- b) 49
- c) 625
- d) 470
- e) 4.8

Q14: B

Q15:

- a) 36
- b) A

Q16: 35

Topic 7: Spectra**Irradiance calculations: Questions (page 134)**

Q1: e) 100 W m^{-2}

Q2: e) 2.88 MJ

Q3: c) 125 W m^{-2}

Q4: c) 40 W m^{-2}

Q5: a) 0.1 mW

Inverse square law: Questions (page 139)

Q6: d) 2 W m^{-2}

Q7: e) 40 W m^{-2}

Q8: c) 114 cm

Q9: d) 125 W m^{-2}

Q10: c) 140 W m^{-2}

Energy level calculations: Questions (page 147)

Q11: c) 6

Q12: d) $4.54 \times 10^{14} \text{ Hz}$

Q13: b) 2

Q14: b) 91 nm

Q15: a) $1.40 \times 10^{-19} \text{ J}$

End of topic 7 test (page 150)**Q16:** 1.3**Q17:** 3.5**Q18:** 0.35**Q19:** B**Q20:** 1.2**Q21:** 3.6**Q22:** 3.2×10^{-21} **Q23:** 2.3×10^{-18} **Q24:** 5.44×10^{14} **Q25:** -15.2×10^{-19}

Topic 8: End of unit test**Open ended questions and skill based questions (page 154)****Q1:**

(3 marks)

The following points could be included in your answer:

- Stars produce energy by fusion reactions.
- In a fusion reaction the total mass after the reaction is less than the total mass before the reaction.
- The missing mass is converted to energy.
- This would happen in both a star and a fusion reactor.
- The energy could be produced as heat and or light so it is likely that a fusion reactor may produce light just like a star.
- A fusion reactor must have some means of containing the nuclei/plasma.
- The container could not be a normal jar because the temperature required for a fusion reaction is much greater than a glass jar could withstand.
- In a star gravity holds the plasma in place.
- In a fusion reactor it is likely that a magnetic field will hold the plasma in place.
- The plasma is made of moving charged particles.
- When these charged particles are acted upon by a magnetic field, the particles experience a force.
- This force could be used to hold the plasma together.
- As the temperature of the plasma in both the sun and in a fusion reactor is very high, the charged particles are moving very quickly.

The following equation could be included in your answer

$$E = m c^2$$

Where m = mass lost during fusion reaction.

Your answer must be structured so that it is logical when read.

Q2:

(4 marks)

Step 1

Frequency of photon just greater than violet, see data sheet.

$$\lambda \text{ about} = 390 \text{ nm}$$

$$v = f\lambda$$

$$3 \times 10^8 = f \times 10^{-9}$$

$$f = 7.69 \times 10^{14} \text{ Hz}$$

Step 2

$$E_k = hf - hf_0$$

$$E_k = 6.63 \times 10^{-34} \times 7.69 \times 10^{14} - 6.63 \times 10^{-34} \times 4.7 \times 10^{14}$$

$$E_k = 2.0 \times 10^{-19} \text{ J}$$

Q3:

(4 marks)

Accuracy

Find the average value and compare to the expected value.

Method 1 average = $2.40 \times 10^6 \text{ m s}^{-1}$.

Method 2 average = $2.43 \times 10^6 \text{ m s}^{-1}$.

Method 2 is more accurate because its average value is nearer the expected value.

Precision

Find the percentage uncertainty in each method and compare these.

Method 1

$$\text{random uncert} = \frac{\text{max value} - \text{min value}}{\text{number}}$$

$$\text{random uncert} = \frac{2.59 \times 10^6 - 2.26 \times 10^6}{6}$$

$$\text{random uncert} = 0.055 \times 10^6 \text{ m s}^{-1}$$

$$\% \text{ uncert} = \frac{\text{random uncert} \times 100}{\text{average velocity}}$$

$$\% \text{ uncert} = \frac{0.055 \times 10^6 \times 100}{2.40 \times 10^6}$$

$$\% \text{ uncert} = 2.3\%$$

Method 2

$$\text{random uncert} = \frac{\text{max value} - \text{min value}}{\text{number}}$$

$$\text{random uncert} = \frac{2.64 \times 10^6 - 2.21 \times 10^6}{6}$$

$$\text{random uncert} = 0.072 \times 10^6 \text{ m s}^{-1}$$

$$\% \text{ uncert} = \frac{\text{random uncert} \times 100}{\text{average velocity}}$$

$$\% \text{ uncert} = \frac{0.072 \times 10^6 \times 100}{2.43 \times 10^6}$$

$$\% \text{ uncert} = 3.0\%$$

Since method 1 has the lower percentage uncertainty, it has the greater precision.

Q4:

(3 marks)

Step 1: find gradient

There are many different ways of writing the first line of the gradient calculation.

$$\text{gradient} = \frac{\Delta y}{\Delta x} = \frac{y_2 - y_1}{x_2 - x_1} = \frac{\text{rise}}{\text{run}}$$

$$\text{gradient} = \frac{\Delta \text{Irradiance}}{\Delta \left(\frac{1}{r^2}\right)}$$

$$= \frac{44-0}{20-0}$$

$$= 2.2 \text{ (W)}$$

Step 2: find power of lamp

$$I = \frac{P}{4 \times \pi \times r^2}$$

$$I \times r^2 = \frac{P}{4 \times \pi}$$

$$\text{gradient} = \frac{I}{\frac{1}{r^2}} = I \times r^2 = \frac{P}{4 \times \pi}$$

$$2.2 = \frac{P}{4 \times \pi}$$

$$P = 28 \text{ W}$$

Note: you must use the gradient of the best line and not individual data points when calculating the gradient.

Q5:

(3 marks)

The following points could be included in your answer:

- One difference is you could take a watch apart and look at it before you make it collide. You cannot do this with the particles in a particle collider.
- When two watches are slammed together many small parts are produced. Difficult to know which part came from which watch. Difficult to fit these parts together.
- If you repeat the collision of watches you will not always end up with the same small pieces. It is the same in a particle collider; colliding the same two particles will not always result in the same products.
- In a collision of particles there are basic rules which must be conserved eg conservation of charge, mass/energy, spin. In a particle collider many subatomic particles are produced eg bosons, mesons, muons. Some of these exist for only a very short time.
- The charged particles that are produced in a particle collider can be separated and analysed using magnetic detectors.

Your answer must be structured so that it is logical when read.

Course style questions (page 156)**Q6:**

1. a) Diameter of nucleus or any other suitable example. (1 mark)
- b) Diameter of sun, radius of Earth's orbit around the sun or any other suitable example. (1 mark)
2. In an electron gun/oscilloscope a negatively charged particle is accelerated. When this particle hits a screen light is emitted. Or any other suitable example. (2 marks)
3. a) $a=1, b=1$ (1 mark)
- b) Proton (1 mark)
4. a) Positron (1 mark)
- b) Electrons and positrons have the same mass.
Electrons have a charge of -1 while positrons have a charge of +1. (1 mark)
- c) When an electron and a positron collide, the electron and positron annihilate and produce a gamma ray. In the universe there are many electrons so any positron is likely to come close to an electron. (1 mark)

Q7:

1. a) 50,000 J of work is done on each one coulomb of charge as it moves across this voltage.
Or:
The work done on each one coulomb of charge is 50,000 J. (1 mark)
- $W = V \times Q$
- b) $W = 50 \times 10^3 \times 1.6 \times 10^{-19}$
 $W = 8.0 \times 10^{-15} J$ (2 marks)
- Total work done on proton = $4 \times 8.0 \times 10^{-15}$
 $= 3.2 \times 10^{-14} J$
- c) Total energy at end of tubes = $3.0 \times 10^{-15} + 3.2 \times 10^{-14}$
 $= 3.2 \times 10^{-14} J$
- $E_k = \frac{1}{2}mv^2$
- $3.5 \times 10^{-14} = \frac{1}{2} \times 1.673 \times 10^{-27} \times v^2$
 $v = 6.5 \times 10^6 ms^{-1}$ (5 marks)

- d) A proton accelerates as it goes along the tubes so if all tubes were the same length, the time taken to travel along successive tubes would decrease.

Or:

Since it is a constant frequency a.c. supply, the tubes must become longer to ensure that the time taken remains the same. This ensures that the proton will always experience a force that will accelerate it across the gap.

(2 marks)

- e) Moving protons (charges) experience a force in a magnetic field. This force can direct the protons into a beam.

(1 mark)

Q8:

1. Fusion reaction

(1 mark)

2. a) The number of protons in the nucleus

(1 mark)

- b) The number of protons + the number of neutrons in the nucleus

(1 mark)

$$\begin{aligned} \text{Total mass before reaction} &= 1.673 \times 10^{-27} + 3.344 \times 10^{-27} \\ &= 5.017 \times 10^{-27} \text{ kg} \end{aligned}$$

$$\text{Total mass after reaction} = 5.007 \times 10^{-27} \text{ kg}$$

3. Mass lost after reaction = $1.0 \times 10^{-27} \text{ kg}$

$$E = mc^2$$

$$\begin{aligned} E &= 1.0 \times 10^{-29} \times (3 \times 10^8)^2 \\ &= 9 \times 10^{-13} \text{ J} \end{aligned}$$

(3 marks)

4. As a star gets older, more of the hydrogen has been used in fusion reactions to form helium (and other heavier elements). The proportion of helium (and other heavier elements) increases as time goes on.

(2 marks)

Q9:

1. a) As the light enters the glass the speed changes. This causes the direction to change.

(1 mark)

- b) Find the gradient of the line. You must not use data points.

$$\text{gradient} = \frac{\Delta y}{\Delta x} = \frac{y_2 - y_1}{x_2 - x_1} = \frac{\text{rise}}{\text{run}}$$

$$\text{gradient} = \frac{\Delta \sin \theta_1}{\Delta \sin \theta_2}$$

$$= \frac{0.4 - 0}{0.3 - 0}$$

$$= 1.3$$

(3 marks)

2. a) You must start with this equation.

$$n = \frac{\lambda_{air}}{\lambda_{liquid}}$$

$$n = \frac{633}{452}$$

$$n = 1.4$$

(2 marks)

- b) **Method 1, find critical angle:**

$$n = \frac{1}{\sin \theta_{critical}}$$

$$1.4 = \frac{1}{\sin \theta_{critical}}$$

$$\theta_{critical} = 45.6^\circ$$

Since θ_{water} is greater than the critical angle, total internal reflection will occur.

Or:

Method 2

$$n = \frac{\sin \theta_1}{\sin \theta_2}$$

$$1.4 = \frac{\sin \theta_1}{\sin 58}$$

$$\sin \theta_1 = 1.19$$

No value can be found for θ_1 (or θ_{air}). This means that total internal reflection must take place.

For both methods finish off with the following description. Light will reflect off the surface of the liquid and stay in the liquid as shown in the following diagram.

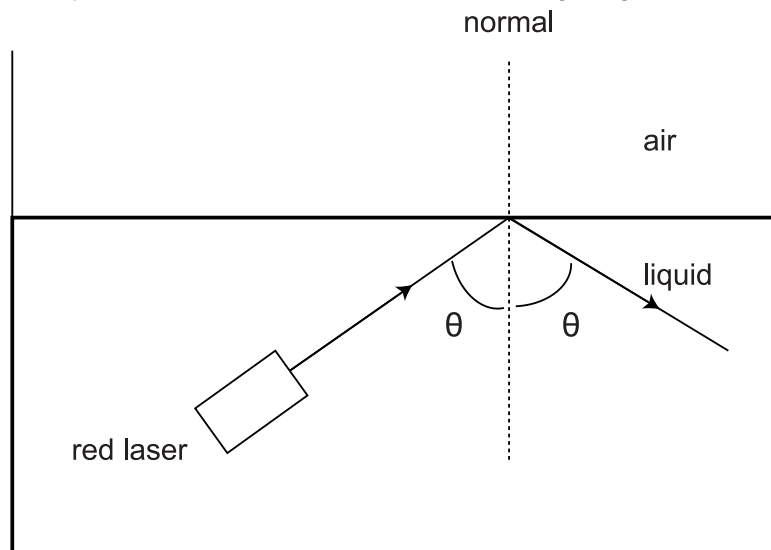

(4 marks)

3. White light contains all the colours/wavelengths/frequencies in the visible spectrum. The refractive index of red is less than the refractive index of violet. This means that the critical angle of red light is greater than the critical angle of violet light. Therefore if red is totally internally reflected so will all the other wavelengths in the visible spectrum. A beam of white light will be seen reflecting down into the liquid instead of the red light that is shown in the diagram above.

(3 marks)

Q10:

1. At a maximum the waves are arriving in phase. At a minimum the waves arriving out of phase (by half a wavelength).

(1 mark)

2.

$$\text{path difference} = \left(m + \frac{1}{2}\right)\lambda$$

$$1.05 = \left(1 + \frac{1}{2}\right)\lambda$$

$$\lambda = 0.70\text{m}$$

(3 marks)

3. As the frequency is increased, the wavelength of the waves decreases. The path difference to this point remains constant, 1.05 m. At some wavelengths the path difference = $m\lambda$ so a max will be detected. At some wavelengths the path difference = $(m + 1/2)\lambda$, so a min will be detected.

(2 marks)

4. Agree with student, lower frequency allows higher precision. At low frequency wavelength is large. Values of path difference for maxima or minima will become greater so there will be a smaller **percentage** reading uncertainty in the measurements.

(2 marks)

End of unit 2 test (page 162)**Q11:** The correct statements are: 1, 2, 7, 10, 11, 12, 13, 16, 17, 20 and 21**Q12:** $15 \times 10^6 \text{ m s}^{-1}$ **Q13:**

- a) $8.1 \times 10^{-15} \text{ J}$
 b) $2.5 \times 10^4 \text{ V}$
 c) Smaller (increase in) kinetic energy because charge is smaller so less work is done.

Q14:

1. 125
 2. 60

Q15:

1. $0.925 \times 10^{-27} \text{ kg}$
 2. $8.325 \times 10^{-11} \text{ J}$

Q16: d) four times the mass and the same charge.

Q17:

1. $6.0 \times 10^{-19} \text{ J}$
2. $7.9 \times 10^{-19} \text{ J}$

Q18:

- a) 0.68 m
- b) It increases as there is no longer any destructive interference.

Q19:

1. 0.04 mm
2. 436 nm

Q20:

1. waves meet out of phase
2. λ blue light is shorter (than λ red light) and $m\lambda = d \sin \theta$
3. $\theta = 28.3^\circ$

Q21:

1. 21°
2. 32°
3. 42°
4. $2 \times 10^8 \text{ ms}^{-1}$

Q22: 1.8 W m^{-2} **Q23:**

1. 25 W m^{-2}
2. calculation of $I \times d^2$ gives values of 0.28, 0.39, 0.49 respectively, i.e. not a constant so the lamp is **not** a point source.

Q24:

- a) $E_3 \rightarrow E_0$ as $E = hf$ and $v = f \lambda$
- b) $5.9 \times 10^{14} \text{ Hz}$
- c) $4.1 \times 10^{-7} \text{ m}$

Appendix A: Units, prefixes and scientific notation

Quiz questions (page 173)

Q1: c) 1.3

Q2: d) 39 J

Q3: c) 40.9 J